



MOBILE PHONE SERVICE MANUAL

CAUTION

BEFORE SERVICING THE UNIT, READ THE "SAFETY PRECAUTIONS" IN THIS MANUAL

MODEL : LG-K430DSF

<http://eduwebcell.blogspot.com/>

1. INTRODUCTION	3	6. BGA PIN MAP.....	219
1.1 Purpose		7. PCB LAYOUT.....	21:
1.2 Regulatory Information		8. HIDDEN MENU.....	227
2. PERFORMANCE.	4	9. DOWNLOAD.....	22:
2.1 Band Specification		10. CALIBRATION.....	231
2.2 HW Features		11. DISASSEMBLE GUIDE.....	232
2.3 RSSI Display		12. EXPLODED VIEW.....	236
2.4 Current consumption		13. REPLACEMENT PART LIST.....	237
2.5 Battery bar			
2.6 SW Specification			
3. TROUBLE SHOOTING.	13		
3.2 Transceiver DC Power Supply Circuit Block			
3.3 DC-DC Block			
3.4 FEMiD(Front End Module integrated Duplexer) Block			
3.5 GSM RF PART			
3.6 WCDMA RF PART			
3.7 LTE RF PART			
3.8 Checking Wifi/BT Block			
3.9 Checking GPS Block			
3.10 Checking FM Block			
3.11 Checking NFC Block			
3.12 Power			
3.13 charger			
3.14 Audio			
3.15 Checking LCD Block			
3.16 Touch			
3.17 Sensor			
3.18 Checking USB Block			
3.19 Camera			
4. BLOCK DIAGRAM.....	92		
5. CIRCUIT DIAGRAM.....	8:		

1.1 Purpose

This manual provides the information necessary to repair, calibration, description and download the features of this model.

1.2 Regulatory Information

A. Security

This material is prohibited to share and release to unauthorized person, in accordance with the regulations, LG Electronics, Civil / criminal responsibility in accordance with the relevant provisions violate.

B. Precautions for repair

- In case of Disassembly or Assembly to repair product, be careful of a product failure caused by RF signals and Static electricity.
- When using Magnetic tool for the Phone's SVC repair, you should check affect the Electric parts according to effect of Magnet.
- When fastening the screw, be careful not to damage the head of screw and even product.

C. Attention

Boards, which contain Electrostatic Sensitive Device (ESD), are indicated by the  sign.

Following information is ESD handling:

- Service personal should ground themselves by using a wrist, strap when exchange system board.
- When repair are made to a system board, they should spread the floor with anti-static mat which is also grounded.
- Use a suitable, grounded soldering iron.
- Keep sensitive parts in these protective packages until these are used.
- When returning system board or parts like EEPROM to the Factory, use the protective package as described.

2.1 Band Specification

Support Band	TX Freq (MHz)	RX Freq (MHz)
WCDMA(FDD1)	1920 – 1980	2110 – 2170
WCDMA(FDD2)	1852 – 1907	1932 – 1987
WCDMA(FDD5)	824 – 849	869 – 894
WCDMA(FDD8)	880 – 915	925 – 960
EGSM	880 – 915	925 – 960
GSM850	824 – 849	869 – 894
DCS1800	1710 – 1785	1805 – 1880
PCS1900	1850 – 1910	1930 – 1990
LTE3	1710 – 1785	1805 – 1880
LTE7	2500 – 2570	2620 – 2690
LTE28	703 – 748	758 – 803

2.2 HW Features

List	Type / Spec.	
1. Phone Type	DOP Type	
2. Size	146.6 x 74.8 x 8.8	
3. Weight	127.1 g (with Battery)	
4. Battery	2300mAh(Typ) (Li-Ion)	
5. Chipset	MT6753 1.14GHz Octa core	
6. Memory	16GB(EMMC) + 1.5GMB(LPDDR2)	
7. LCD	Size	5.3 inch
	Display Type	Active matrix TFT, Transmissive Type
	Color	16.7M colors
	Resolution	HD (720 x 1280)
8. Touch	Type	In-Cell Touch
9. Main Camera (13M)	Type	CMOS image sensor
	Resolution	13MP @ 30 FPS
	Focus (Laser / OIS)	AF (X/X)
	# of Flash	1EA

2. PERFORMANCE

2.2 HW Features

10. Audio	Receiver/Speaker/3.5phi	1 (AMR-WB) / 1 / Yes
	# of mic.	2
	Audio Zoom	X
11. Bluetooth	Standard	Bluetooth 4.0
	Effective Distance	10M
	Distance	0 m ~ 10 m (depend on environment)
12. WLAN	Standard	IEEE 802.11 b/g/n
	Throughput	Max 40Mbps (SDIO Driver performance)
	Depend on environment	0 ~ 50m (depend on environment)
13. GPS	type	A-GPS
14. FM	type	FM Radio, 3.5pi Ear-jack

2.3 RSSI Display

RSSI BAR	GSM RSSI	WCDMA RSCP	LTE RSRP	Comment
BAR 5->4	- 91dBm± 3dB	- 89dBm± 3dB	-85dBm ± 3dB	1. Call Connected & CIPPH Level =-3.3 2. LTE: RSRP
BAR 4->3	- 96dBm± 3dB	- 94dBm± 3dB	-95dBm ± 3dB	
BAR 3->2	- 99dBm± 3dB	- 100dBm± 3dB	-105dBm ± 3dB	
BAR 2->1	- 103dBm± 3dB	- 104dBm± 3dB	-115dBm ±3dB	
BAR 1->0	- 105dBm± 3dB	- 110dBm± 3dB	-128dBm ± 3dB	

RSSI BAR	GSM RSSI	WCDMA RSSI	LTE RSSI	Comment
BAR 5->4	- 91dBm± 3dB	- 86dBm± 3dB	-85dBm ± 3dB	1. Call Connected & CIPPH Level =-3.3
BAR 4->3	- 96dBm± 3dB	- 91dBm± 3dB	-95dBm ± 3dB	
BAR 3->2	- 99dBm± 3dB	- 97dBm± 3dB	-105dBm ± 3dB	
BAR 2->1	- 103dBm± 3dB	- 101dBm± 3dB	-115dBm ±3dB	
BAR 1->0	- 105dBm± 3dB	- 107dBm± 3dB	-128dBm ± 3dB	

2.4 Current consumption

- Battery Spec. : 2,300mAh(Typ.)/3.8V/Li-Ion

구분	Specification	측정 조건
Sleep mode (WCDMA)	320h over 7 mA under	DRX 7 @ BATT Capacity : 2300mAh
Sleep mode (GSM)	320h over 7 mA under	EGSM P5 @ BATT Capacity : 2300mAh
Sleep mode (LTE)	320h over 7 mA under	DRX 2.56 @ BATT Capacity :2300mAh (AMR Mode)
Calling (WCDMA)	350m over 400mA under	10dBm @ BATT Capacity :2300mAh (AMR Mode)
Calling (GSM)	350m over 400mA under	EGSM, LV5 @ BATT Capacity : 2300mAh
Calling (LTE)	300m over 430mA under	Cat2 Tx 10dBm @ BATT Capacity : 2300mAh
Charging time	4h 20m under	Phone off

2.5 Battery bar

Battery Bar	Specification	Battery Bar	Specification
Bar 20(Full)	98%이상	Bar 9 → Bar 8	43% → 42%
Bar 20 → Bar 19	98% → 97%	Bar 8 → Bar 7	38% → 37%
Bar 19 → Bar 18	93% → 92%	Bar 7 → Bar 6	33% → 32%
Bar 18 → Bar 17	88% → 87%	Bar 6 → Bar 5	28% → 27%
Bar 17 → Bar 16	83% → 82%	Bar 5 → Bar 4	23% → 22%
Bar 16 → Bar 15	78% → 77%	Bar 4 → Bar 3	16% → 15%
Bar 15 → Bar 14	73% → 72%	Bar 3 → Bar 2	13% → 12%
Bar 14 → Bar 13	68% → 67%	Bar 2 → Bar 1	8% → 7%
Bar 13 → Bar 12	63% → 62%	Bar 1 → Bar 0	3% → 2%
Bar 12 → Bar 11	58% → 57%	Power off	1%이하
Bar 11 → Bar 10	53% → 52%	Low battery pop-up	15% , 5%
Bar 10 → Bar 9	48% → 47%	high temperature pop-up	57도, 60도(Power off)

2.6 SW Specification

Item	Feature	Comment
RSSI	0 ~ 5 Levels	
Battery Charging	0 ~ 20 Levels	
Key Volume	0 ~ 7 Level	
Audio Volume	0 ~ 15 Level	
Time / Date Display	Yes	
Multi-Language	Yes	depending on build language
Quick Access Mode	Phone / Messaging / Browser/ Applications	Phone / Contact / Messaging / Applications
PC Sync	Yes	
Speed Dial	Yes	Voice mail center -> 1 key
Profile	Yes	not same with feature phone setting
CLIP / CLIR	Yes	
Phone Book	Name / Number / Email / Groups / Postal addresses / Organizations / IM / Note / Nickname / Website / Event /	There is no limitation on the number of items. It depends on available memory amount.
Last Dial Number	Yes	
Last Received Number	Yes	
Last Missed Number	Yes	
Search by Number/Name	Yes	
Group	Yes	There is no limitation on the number of items. It depends on available memory amount.
Fixed Dial Number	Yes	
Service Dial Number	No	
Own Number	Yes	My Profile (add/edit/delete are supported)

2.6 SW Specification

Voice Memo	Yes	Support voice recorder
Call Reminder	No	
Network Selection	Automatic	
Mute	Yes	
Call Divert	Yes	
Call Barring	Yes	
Call Charge (AoC)	No	
Call Duration	Yes	
SMS (EMS)	There is no limitation on the number of items It depends on available memory amount.	EMS does not support.
SMS Over GPRS	Yes	
EMS Melody / Picture Send / Receive / Save	No	
MMS MPEG4 Send / Receive / Save	Yes	<ul style="list-style-type: none"> ➤ Send / Receive : Yes ➤ Save : depends on content type Support video content type list <ol style="list-style-type: none"> 1. video/mp4 2. video/h263 3. video/3gpp2 video/3gpp
Long Message	MAX 2000 characters	The standard of Open vender
Cell Broadcast	Yes	
Download	Over the Web	
Game	No	
Calendar	Yes	
Memo	Yes	There is no limitation on the number of items. It depends on available memory amount.
World Clock	Yes	

2.6 SW Specification

Unit Convert	No	
Stop Watch	Yes	
Wall Paper	Yes	
WAP Browser	No	Support only web browser based on webkit. WAP stack and wml are not supported.
Download Melody / Wallpaper	Yes	Over web browser
SIM Lock	No	
SIM Toolkit	Yes	
MMS	Yes	OMA MMS 1.2 version
EONS	Yes	
CPHS	Yes	V4.2
ENS	No	
Camera	Yes	13MP AF / 5MP Digital Zoom : x4
JAVA	No	
Voice Dial	No	US English only
IrDa	No	IrRC
Bluetooth	Yes	Ver. 4.2LE [HSP, HFP, A2DP, AVR CP, PBAP, OPP, MAP, HID, PAN, HOGP, HDP, DID]
FM radio	Yes	
GPRS	Yes	Class 12
EDGE	Yes	Class 12(Rx only)
Hold / Retrieve	Yes	
Conference Call	Yes	Max. 6
DTMF	Yes	
Memo pad	No	
TTY	No	
AMR	Yes	
SyncML	No	
IM	Yes	Google Hangout
Email	Yes	IMAP/POP3/SMTP/EAS

3. TROUBLE SHOOTING

3.1 Checking XO Block

The out put frequency(26MHz) of VTCXO(X5001) is used as the reference one of MT6169

Checking Flow

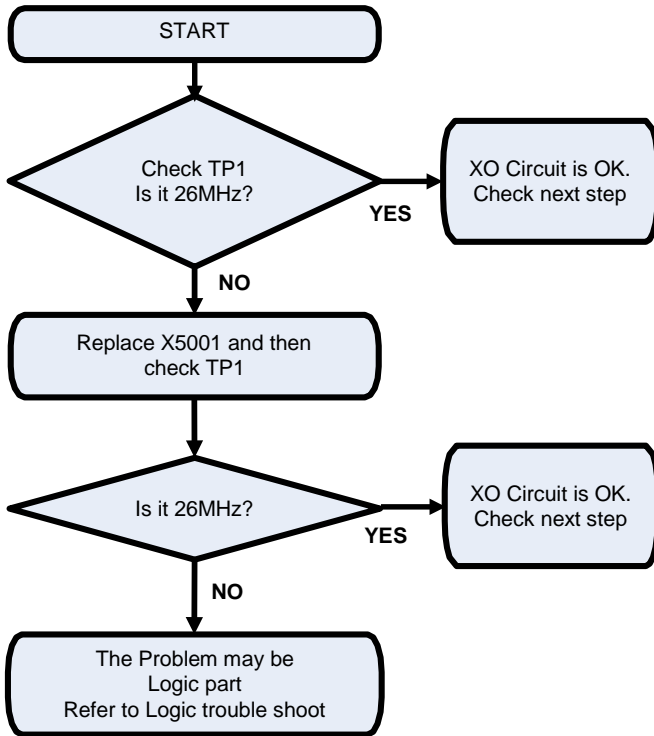

Image

Main Top

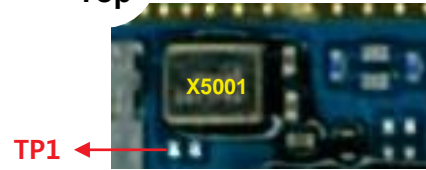

Circuit Diagram

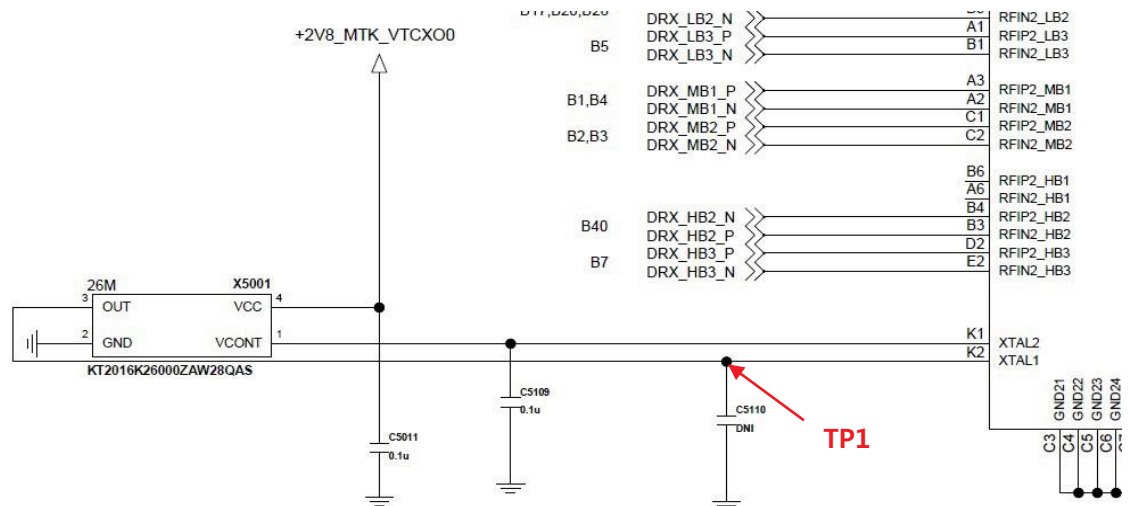

3. TROUBLE SHOOTING

3.2 Checking Transceiver DC Power Supply Circuit Block

The MT6169 operating voltages used two voltage sources 1.8V and 2.8V

Checking Flow

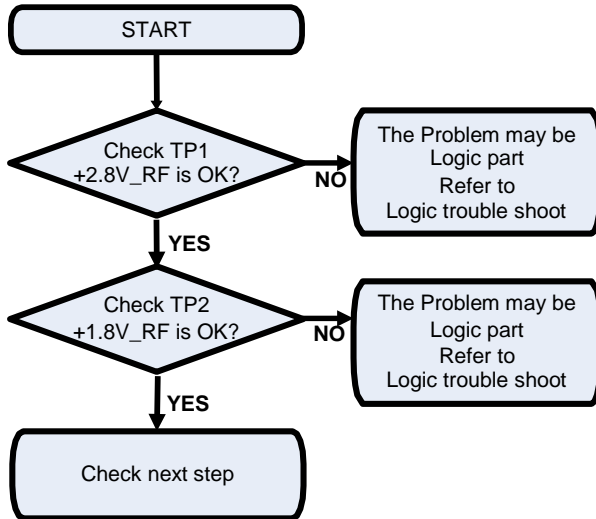

Circuit Diagram

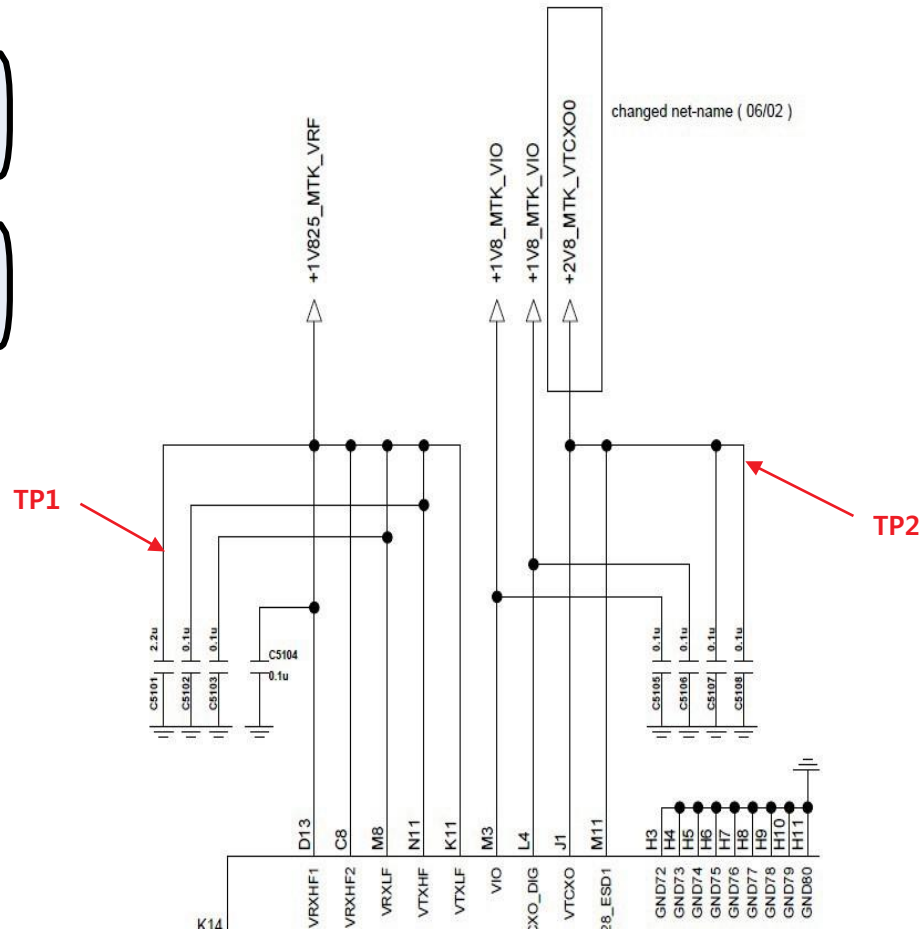

Image

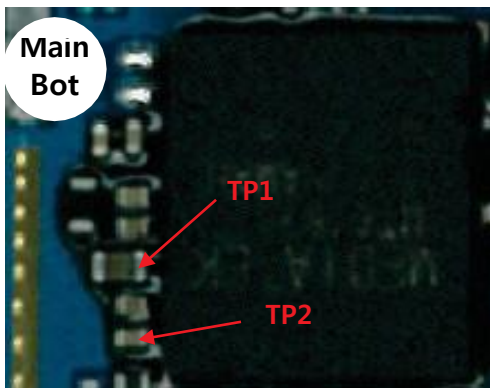

3. TROUBLE SHOOTING

3.3 Checking DC-DC Block

The DC-DC(MT6328, U4100) output voltages is used as the reference one of SKY77643-31

Checking Flow

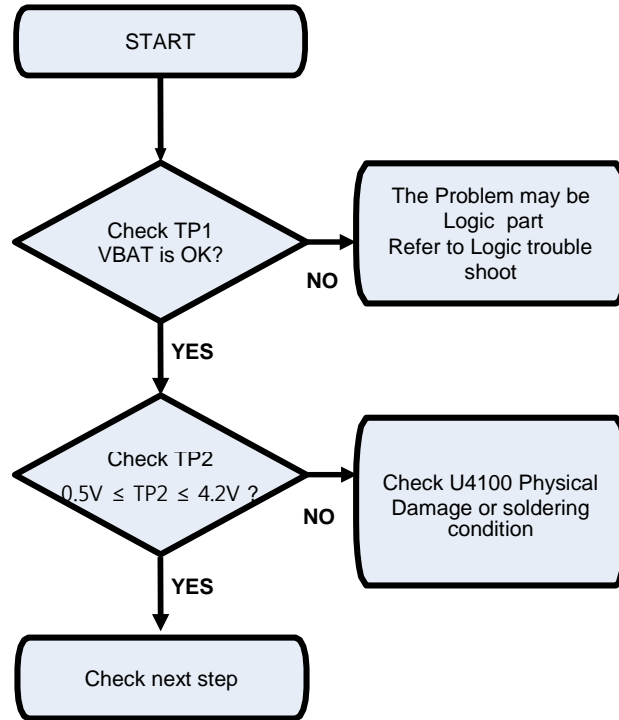

Image

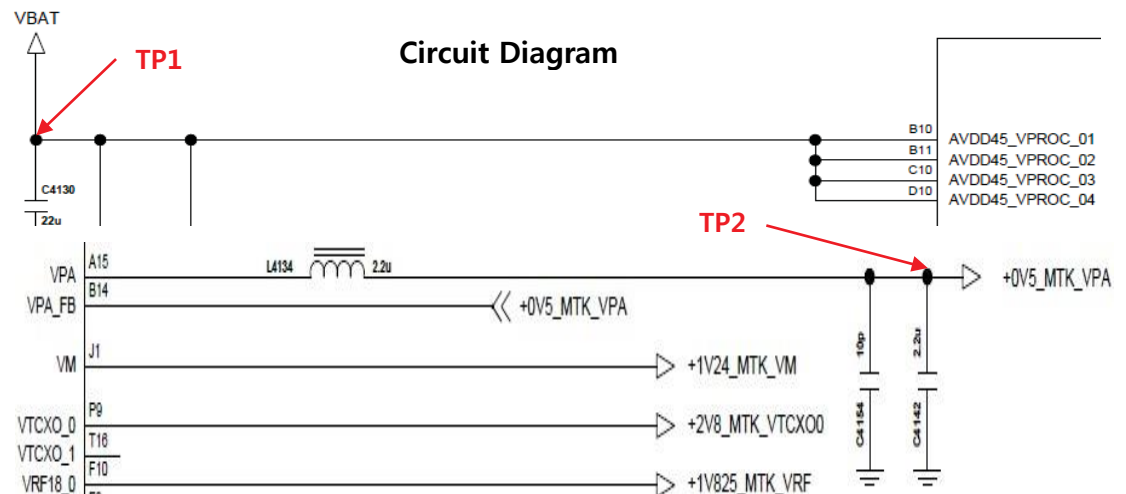
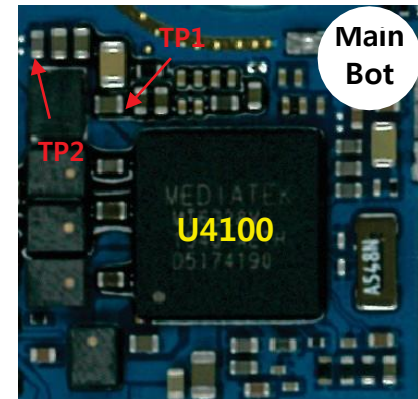

3. TROUBLE SHOOTING

3.4 ASM(Antenna Switch Module) Block

3.4.1 Checking ANT #1 ASM (GSM 850/900, W B5/8, LTE B7/20)

Checking Flow

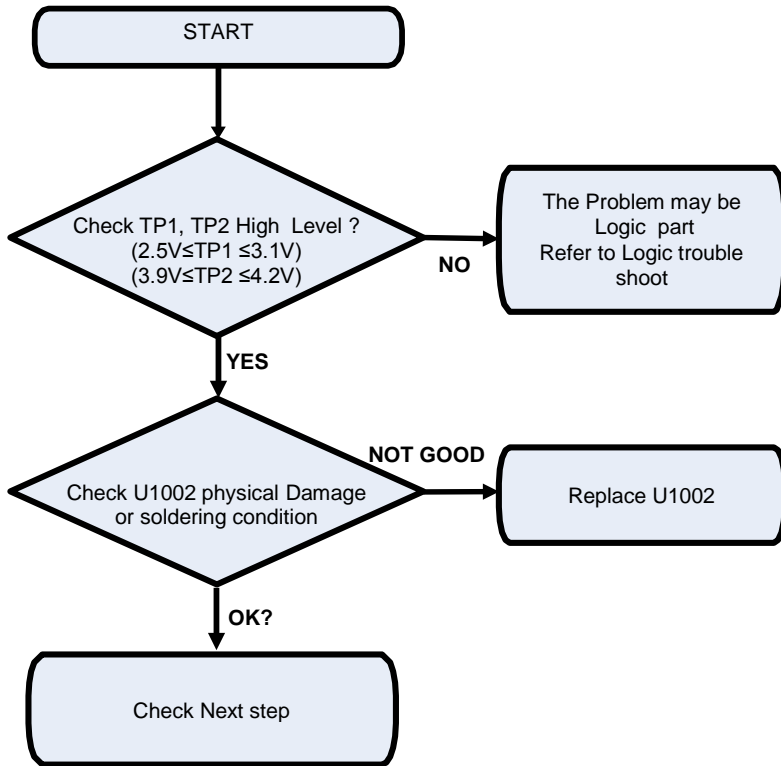

Image

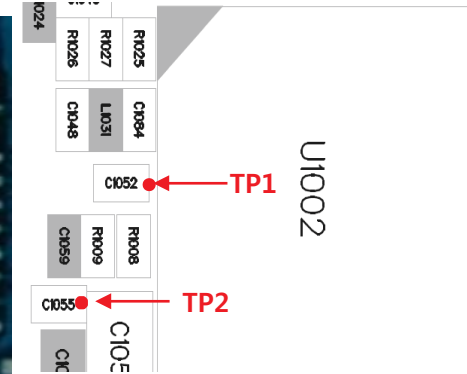
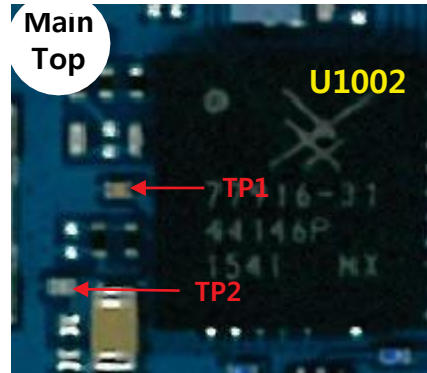

Circuit Diagram

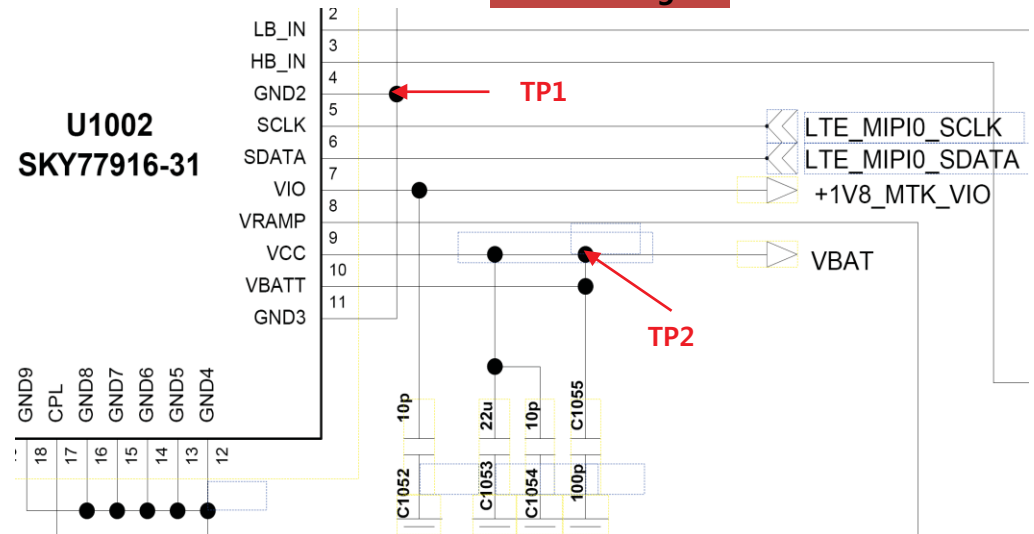

3. TROUBLE SHOOTING

3.4 ASM(Antenna Switch Module) Block

3.4.2 Checking ANT #2 ASM (GSM 1800/1900, W B1 B2, LTE B3)

Checking Flow

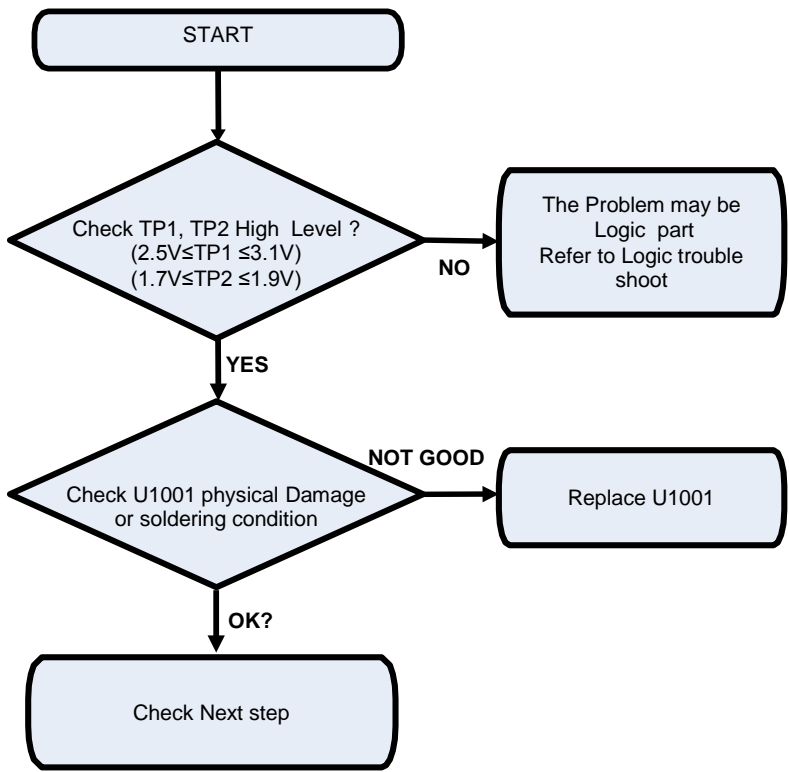

Image

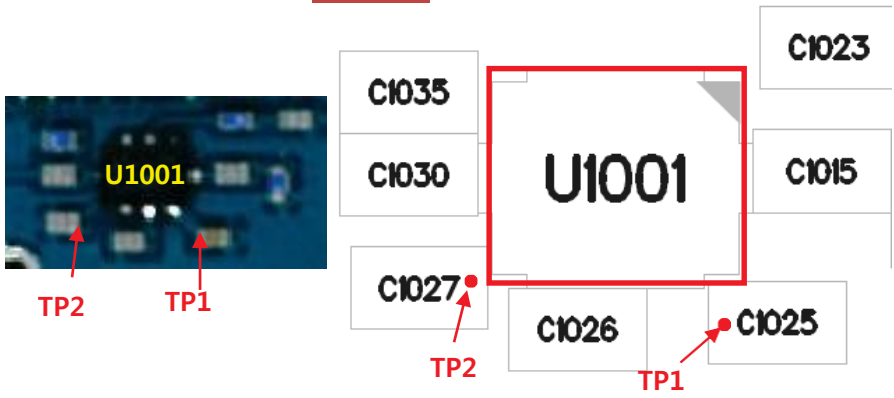

Circuit Diagram

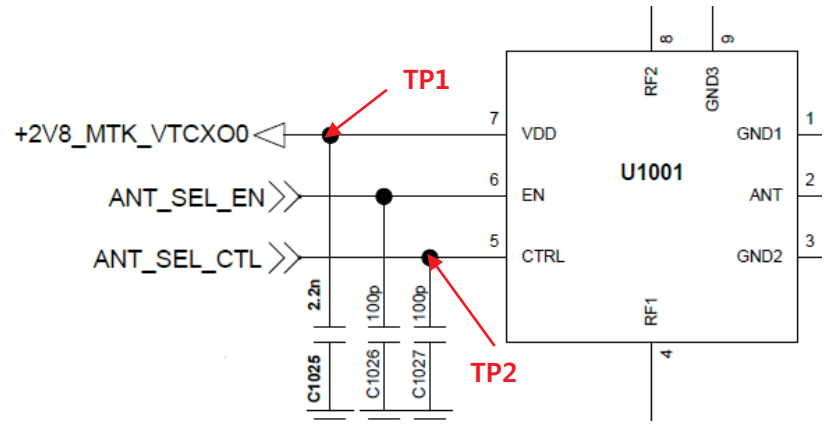

3.5 GSM RF PART

GSM RF Part support GSM850/900/1800/1900 with ASM, PAM, Transceiver component

Checking Flow

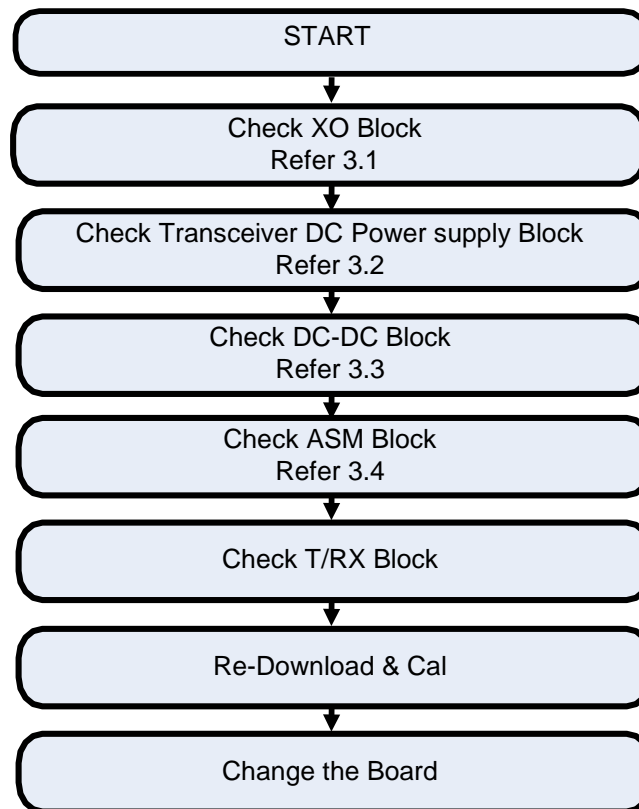

3. TROUBLE SHOOTING

3.5 GSM RF PART

3.5.1 GSM RF Part RX RF PATH

Image

Main
Top

- 1. GSM850 RX PATH
- 2. GSM900 RX PATH
- 3. GSM1800 RX PATH
- 4. GSM1900 RX PATH

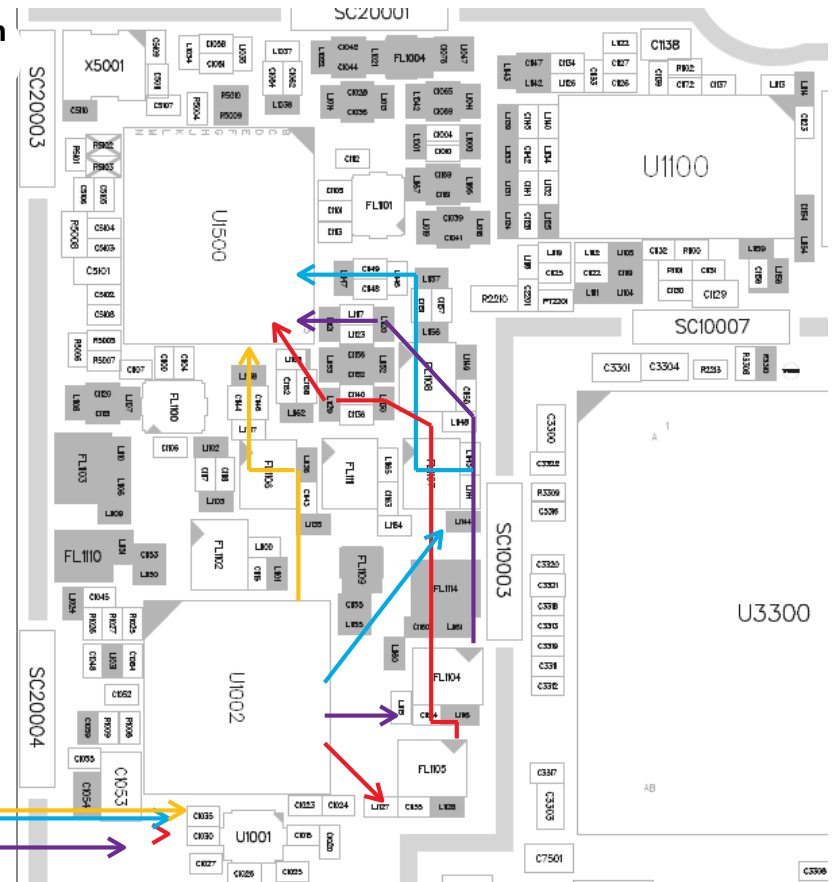

3. TROUBLE SHOOTING

3.5 GSM RF PART

3.5.2 Checking RF Signal RX path(SW, GSM850/900)

Checking Flow

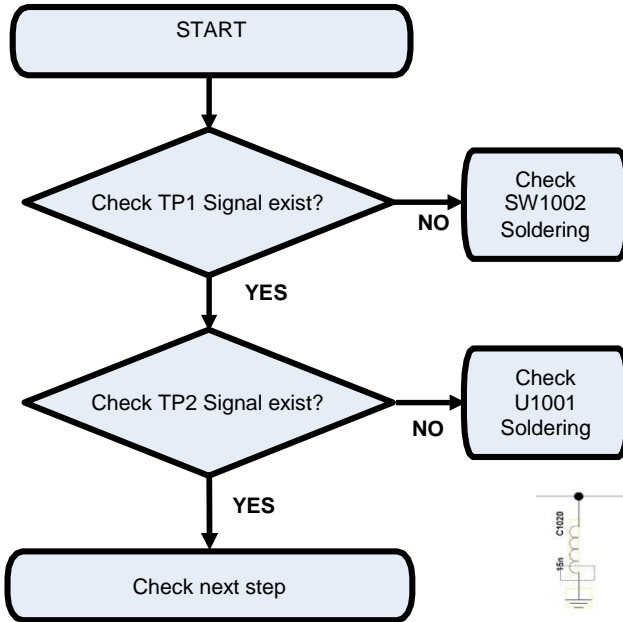

Main Top



Image

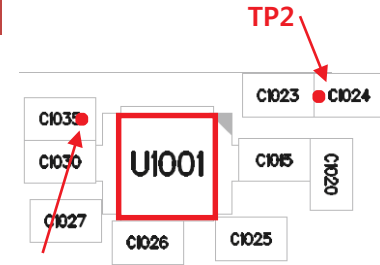

Circuit Diagram

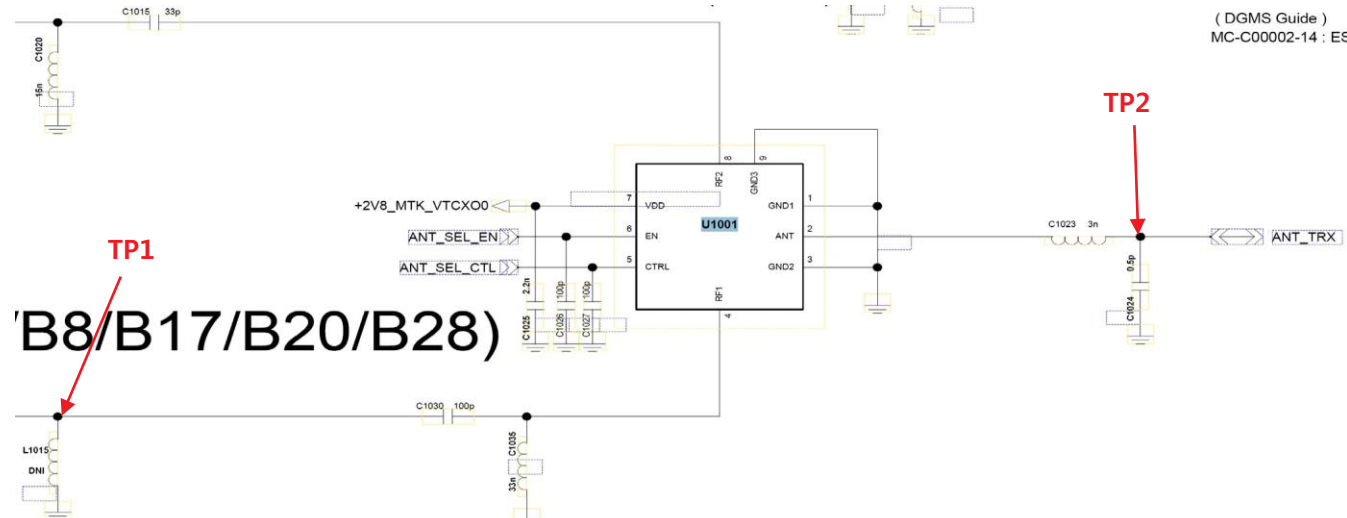

3. TROUBLE SHOOTING

3.5 GSM RF PART

3.5.3 Checking RF Signal RX path(GSM850/900)

Checking Flow

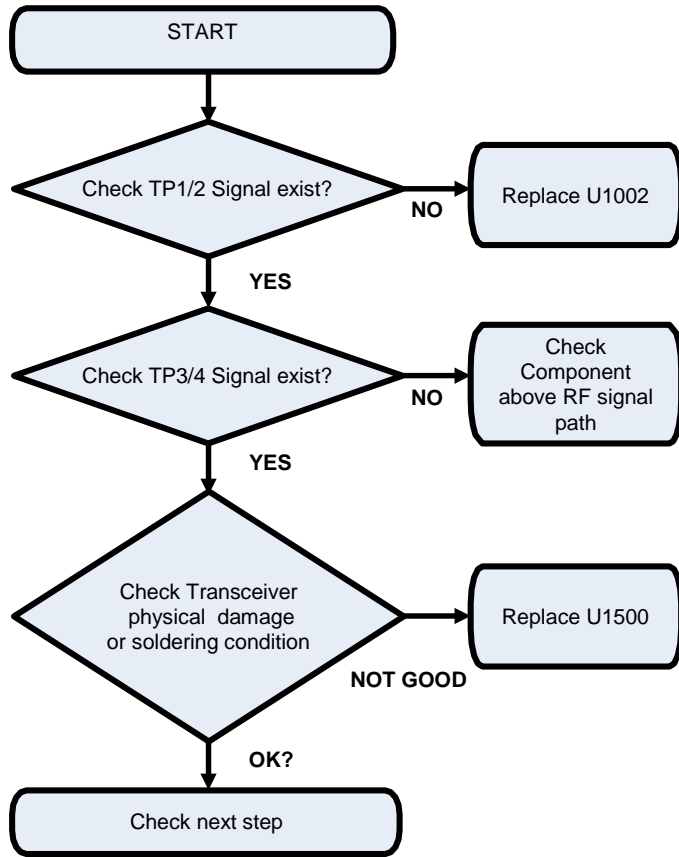

Image

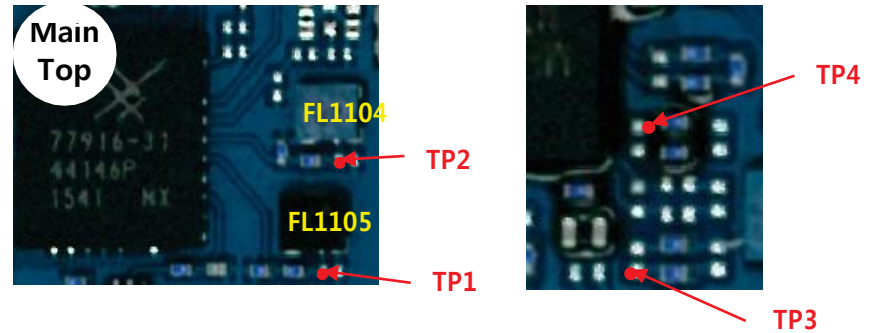

Circuit Diagram

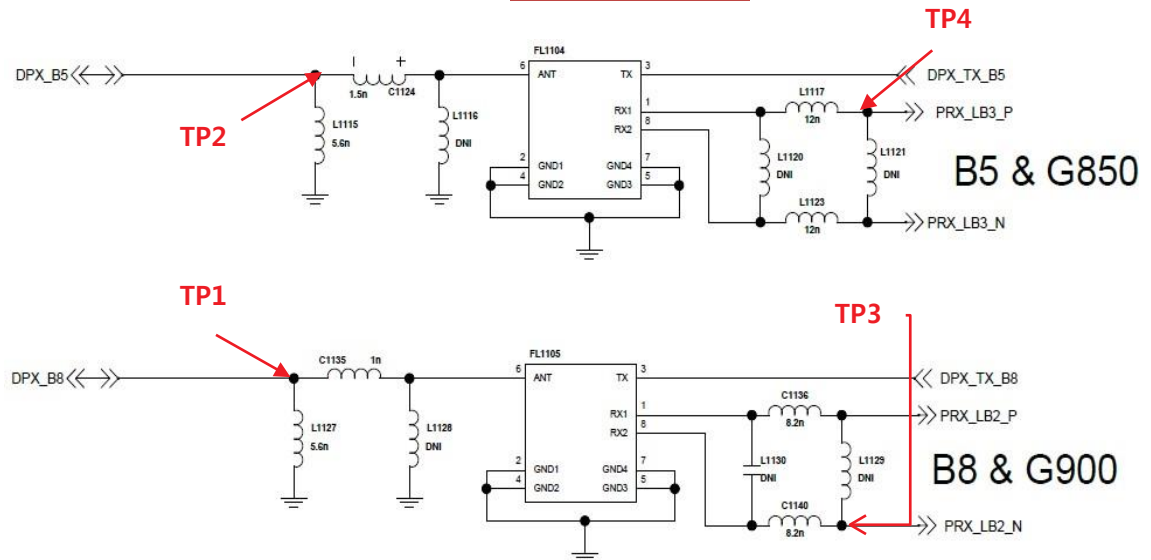

3. TROUBLE SHOOTING

3.5 GSM RF PART

3.5.4 Checking RF Signal RX path(SW, GSM1800/1900)

Checking Flow

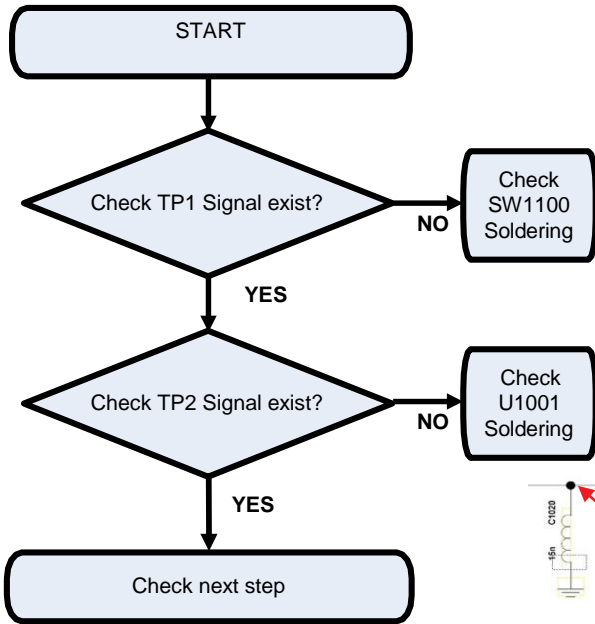

Image

Main Top

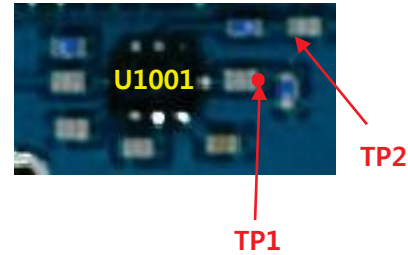

Circuit Diagram

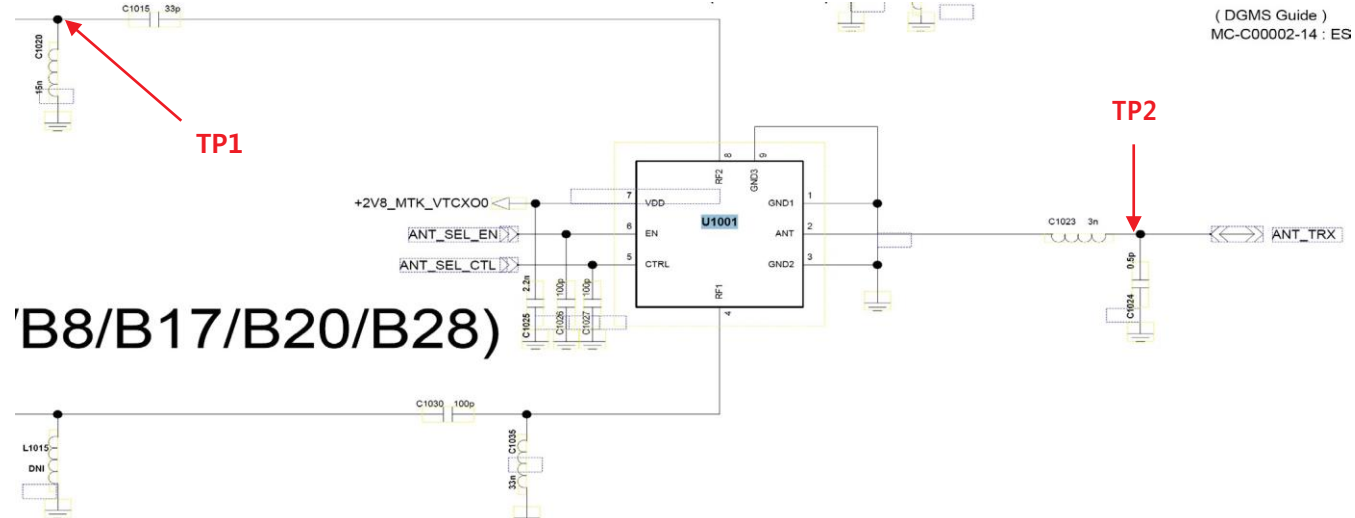

3. TROUBLE SHOOTING

3.5 GSM RF PART

3.5.5 Checking RF Signal RX path(GSM1800/1900)

Checking Flow

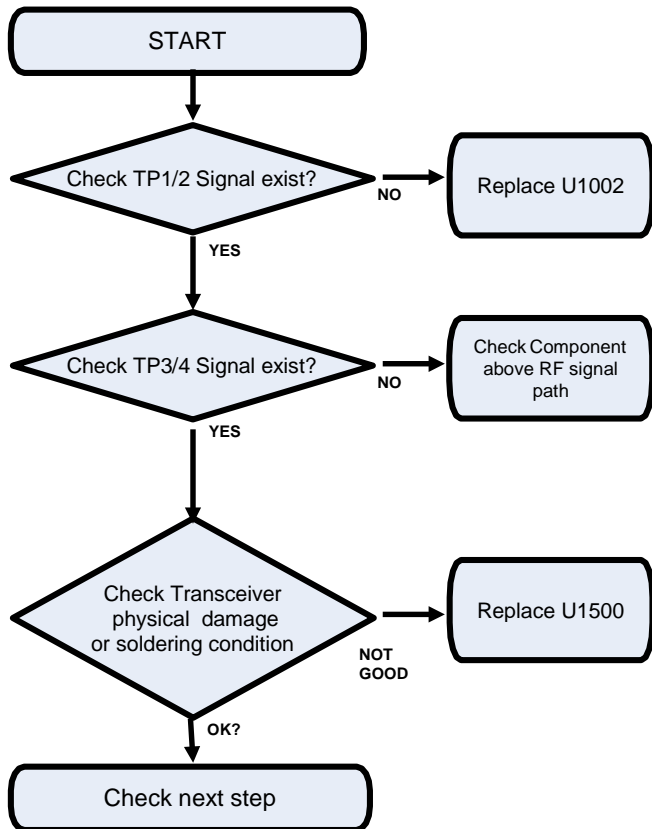

Image

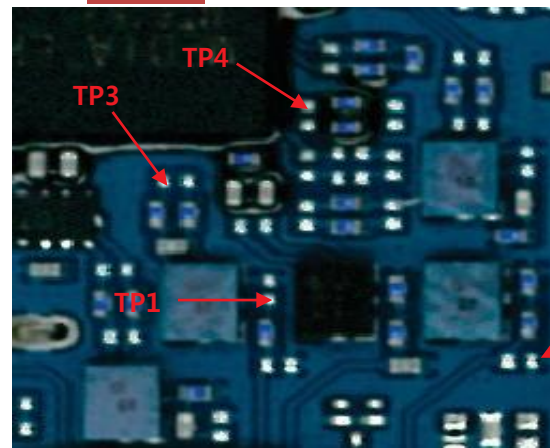

Circuit Diagram

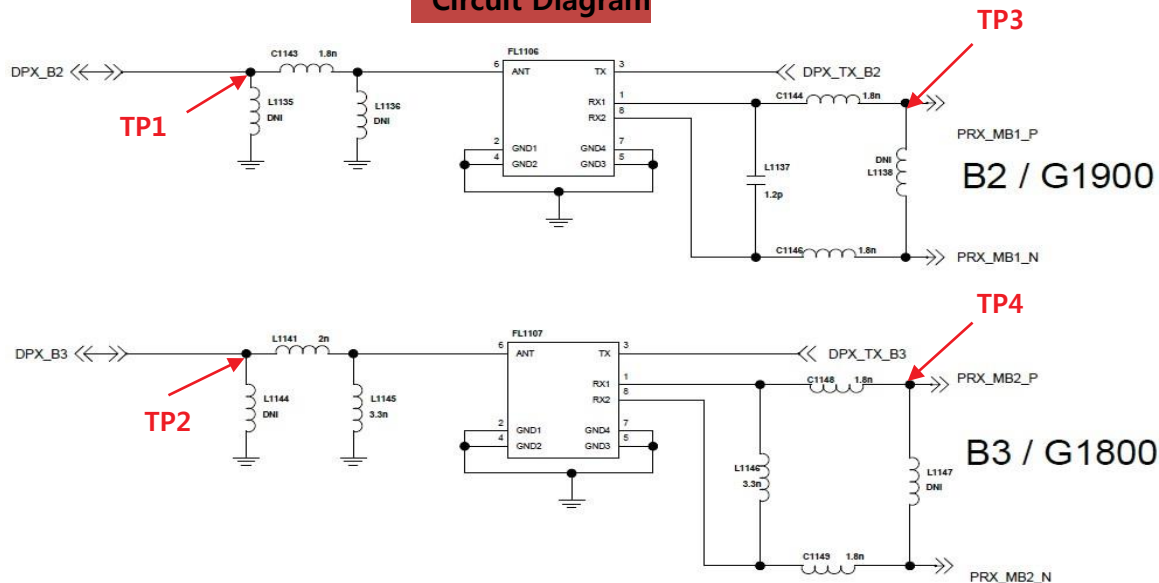

3. TROUBLE SHOOTING

3.5 GSM RF PART

3.5.6 GSM RF Part TX RF PATH

- 1. GSM850 TX PATH
- 2. GSM900 TX PATH
- 3. GSM1800 TX PATH
- 4. GSM1900 TX PATH

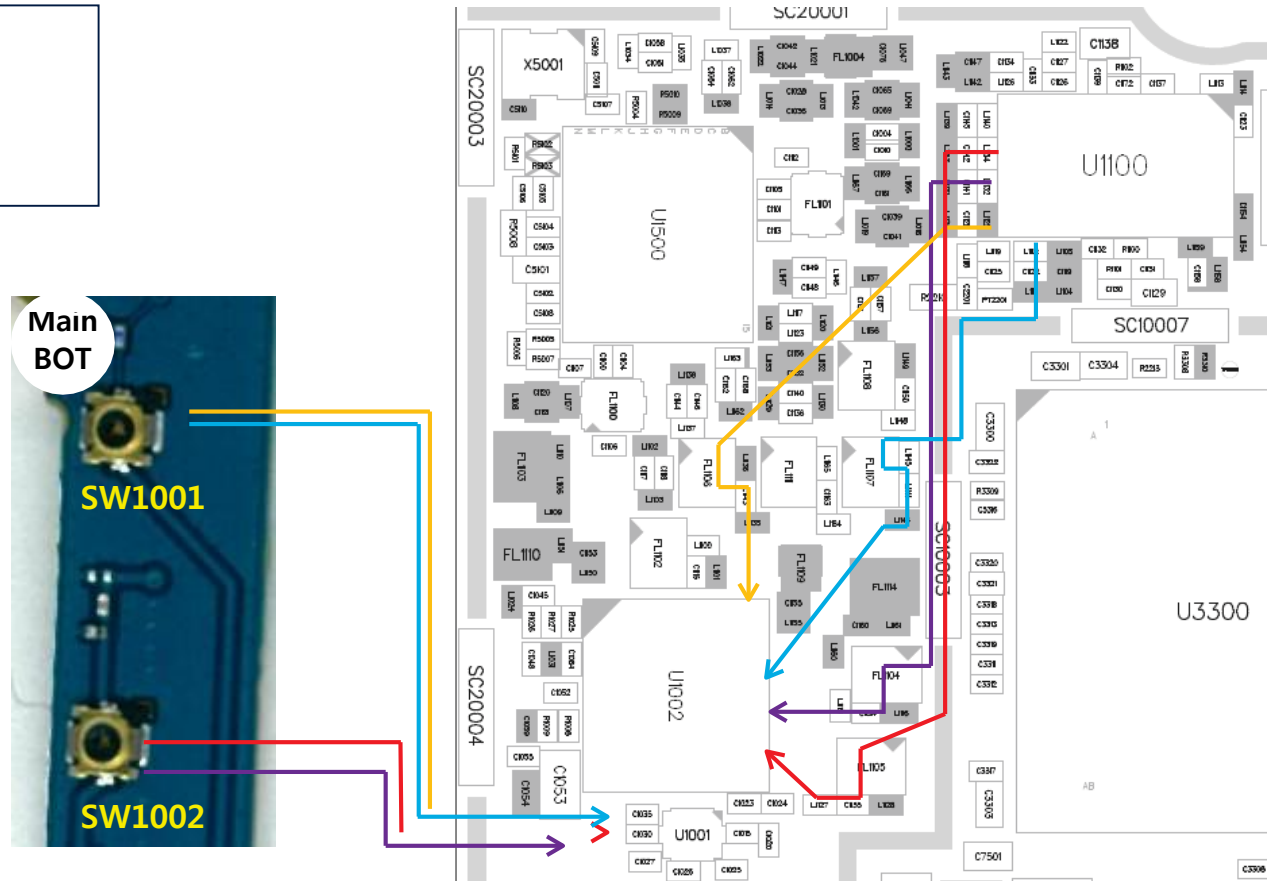

3. TROUBLE SHOOTING

3.5 GSM RF PART

3.5.7 Checking GSM PAM DC Power Circuit

Checking Flow

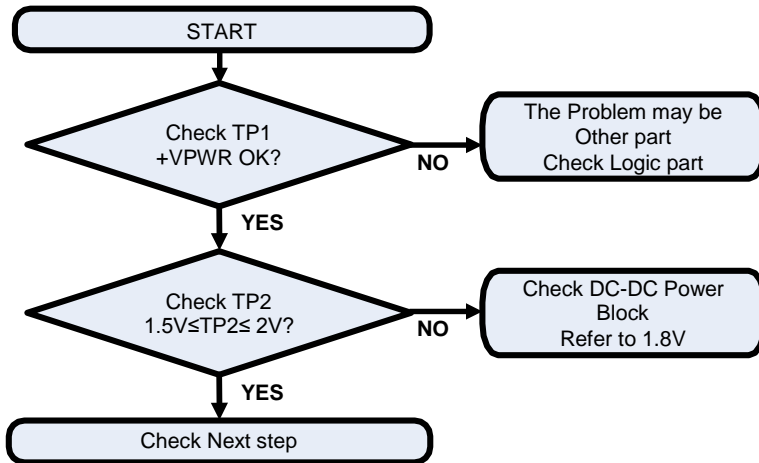

Image

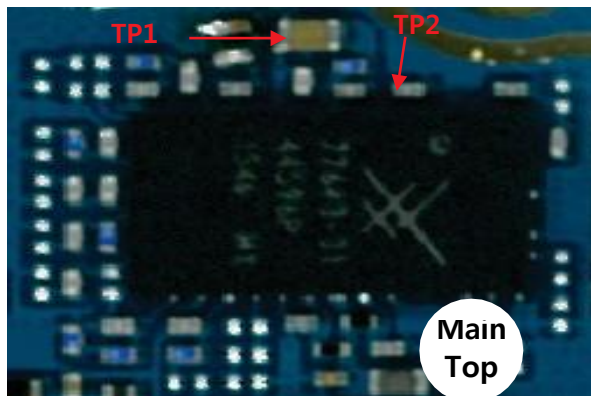

Circuit Diagram

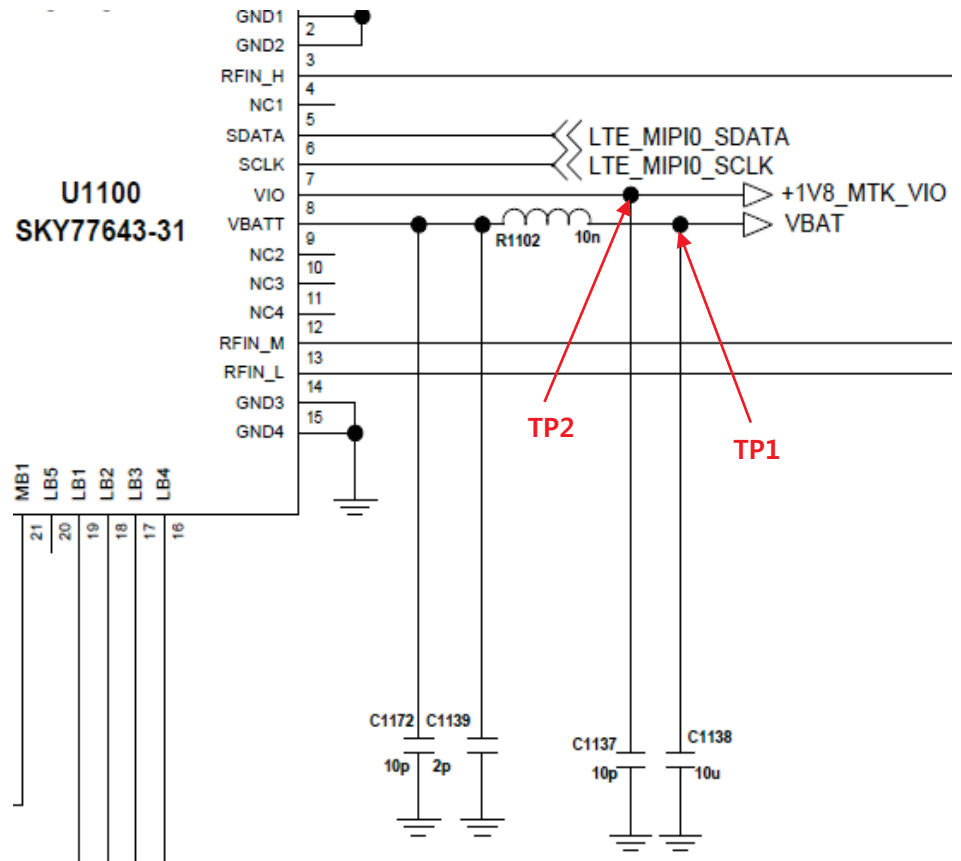

3. TROUBLE SHOOTING

3.5 GSM RF PART

3.5.8 Checking RF Signal TX path(SW, GSM850/900)

Checking Flow

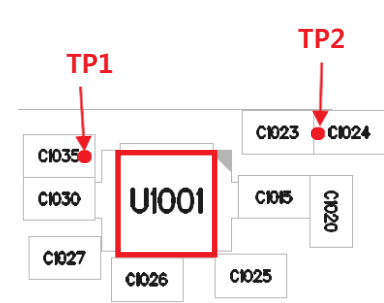
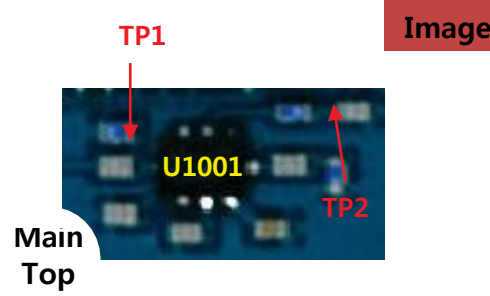
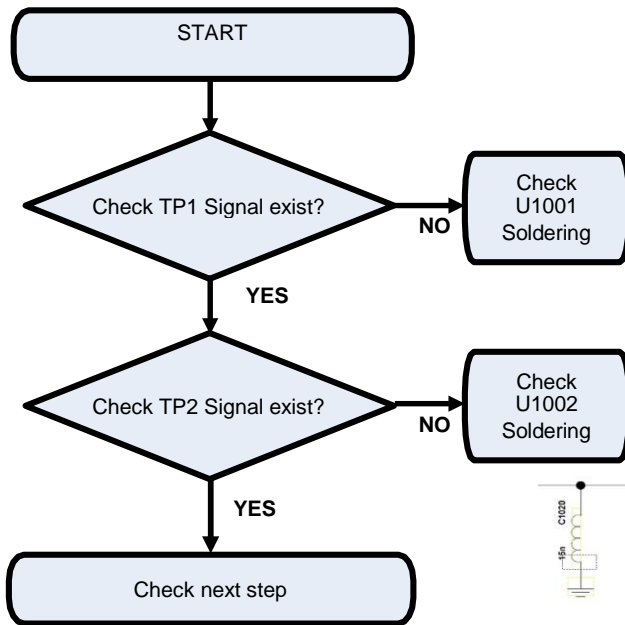

Circuit Diagram

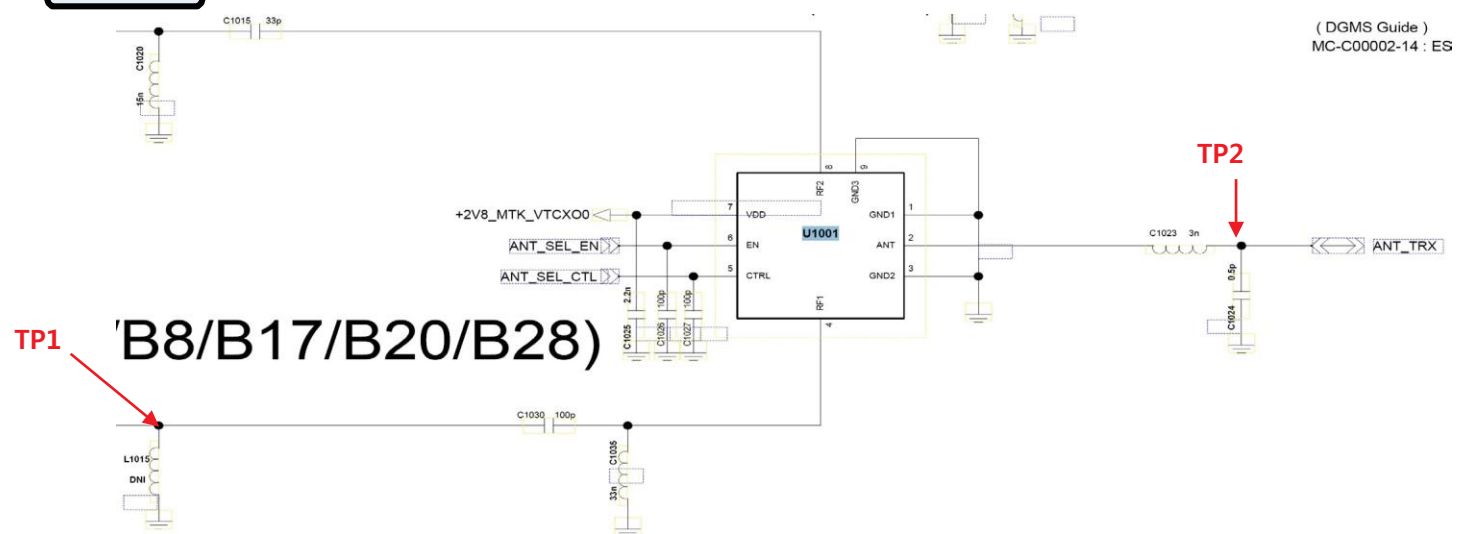

3. TROUBLE SHOOTING

3.5 GSM RF PART

3.5.9 Checking RF Signal TX path(GSM850/900)

Checking Flow

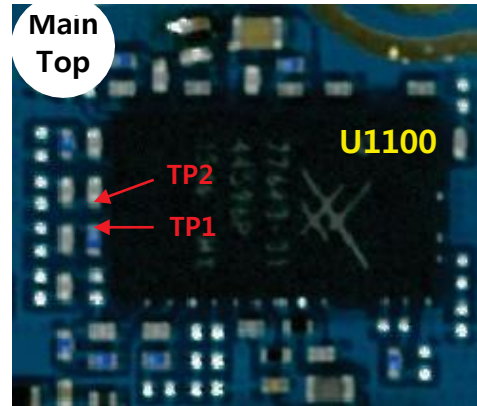
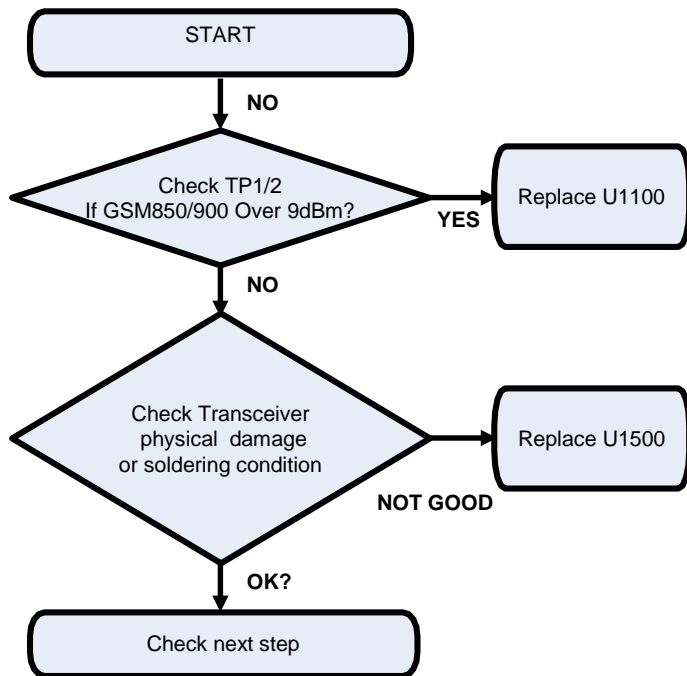

Image

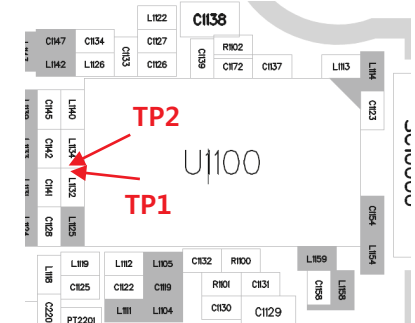

Circuit Diagram

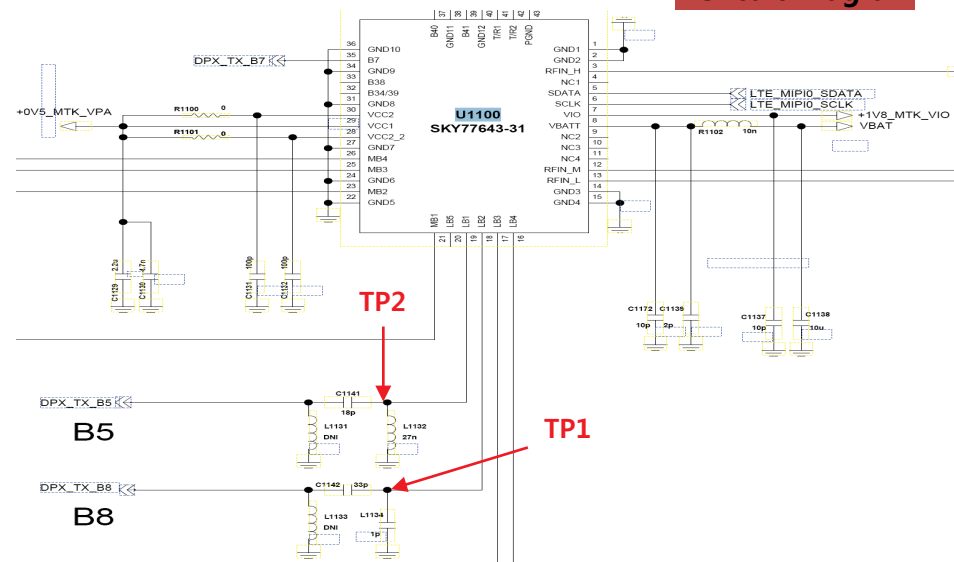

3. TROUBLE SHOOTING

3.5 GSM RF PART

3.5.10 Checking RF Signal TX path(GSM1800/1900)

Checking Flow

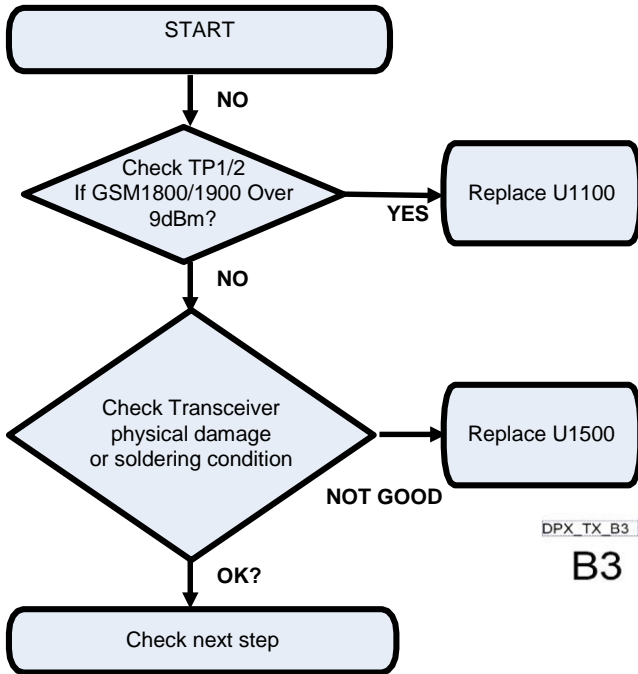

Image

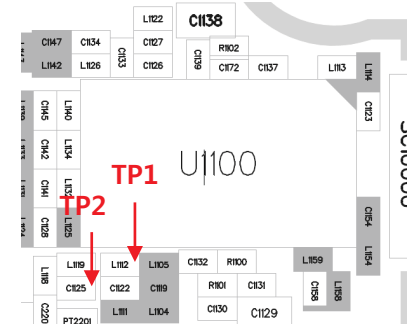
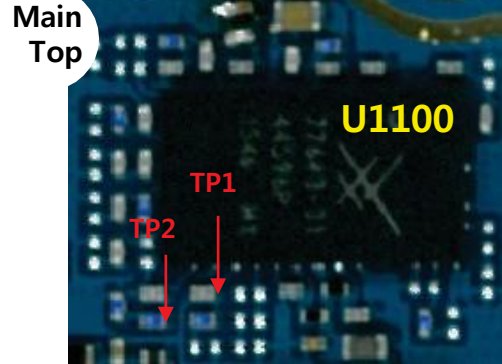

Circuit Diagram

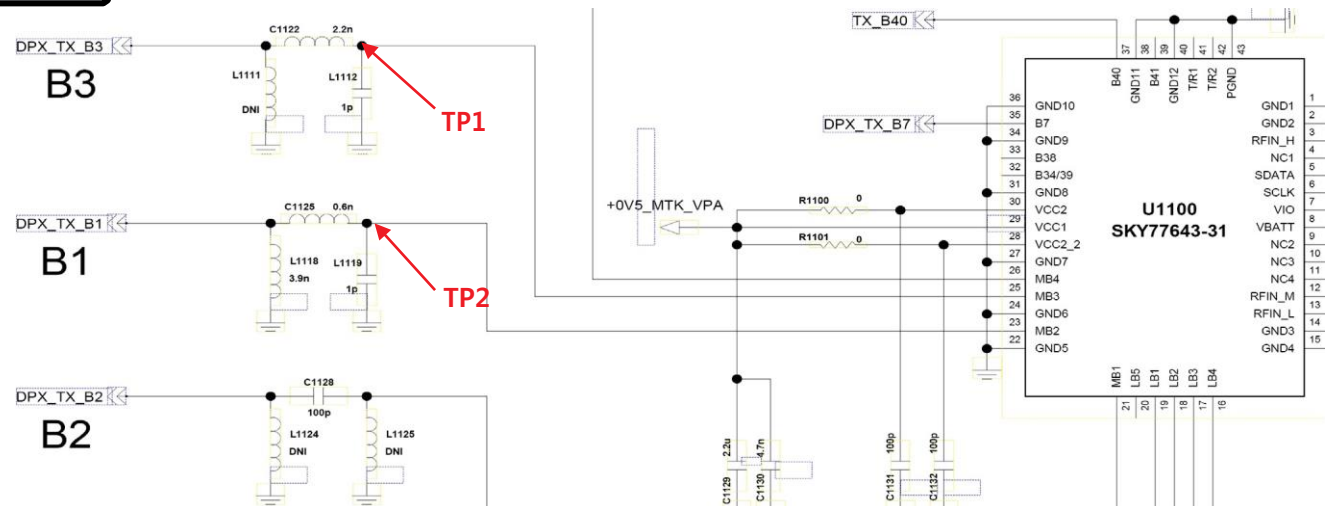

3.6 WCDMA RF PART

WCDMA RF Part support WCDMA B1/2/5/8 with ASM, PAM, Transceiver component

Checking Flow

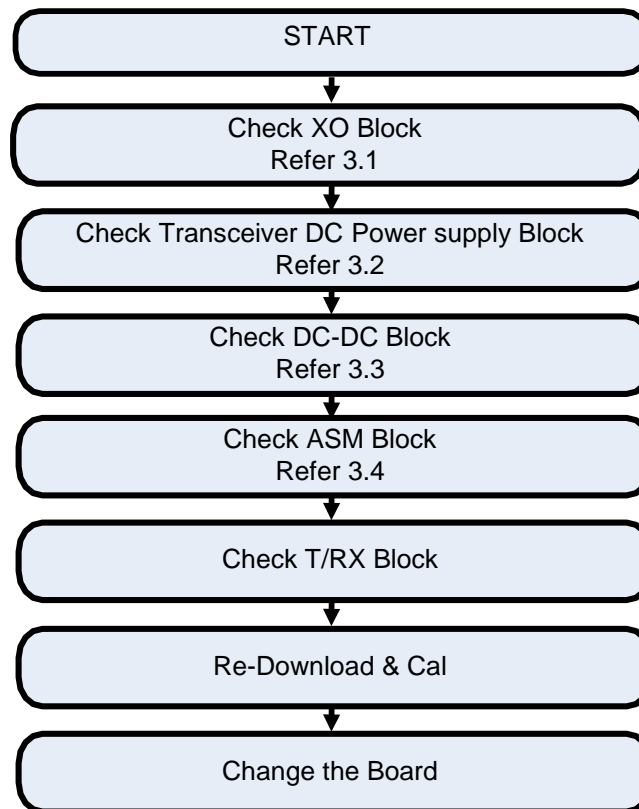

3. TROUBLE SHOOTING

3.6 WCDMA RF PART

3.6.1 WCDMA RF Part RX RF PATH

Image

- 1. WCDMA B5 RX PATH
- 2. WCDMA B8 RX PATH
- 3. WCDMA B1 RX PATH
- 4. WCDMA B2 RX PATH

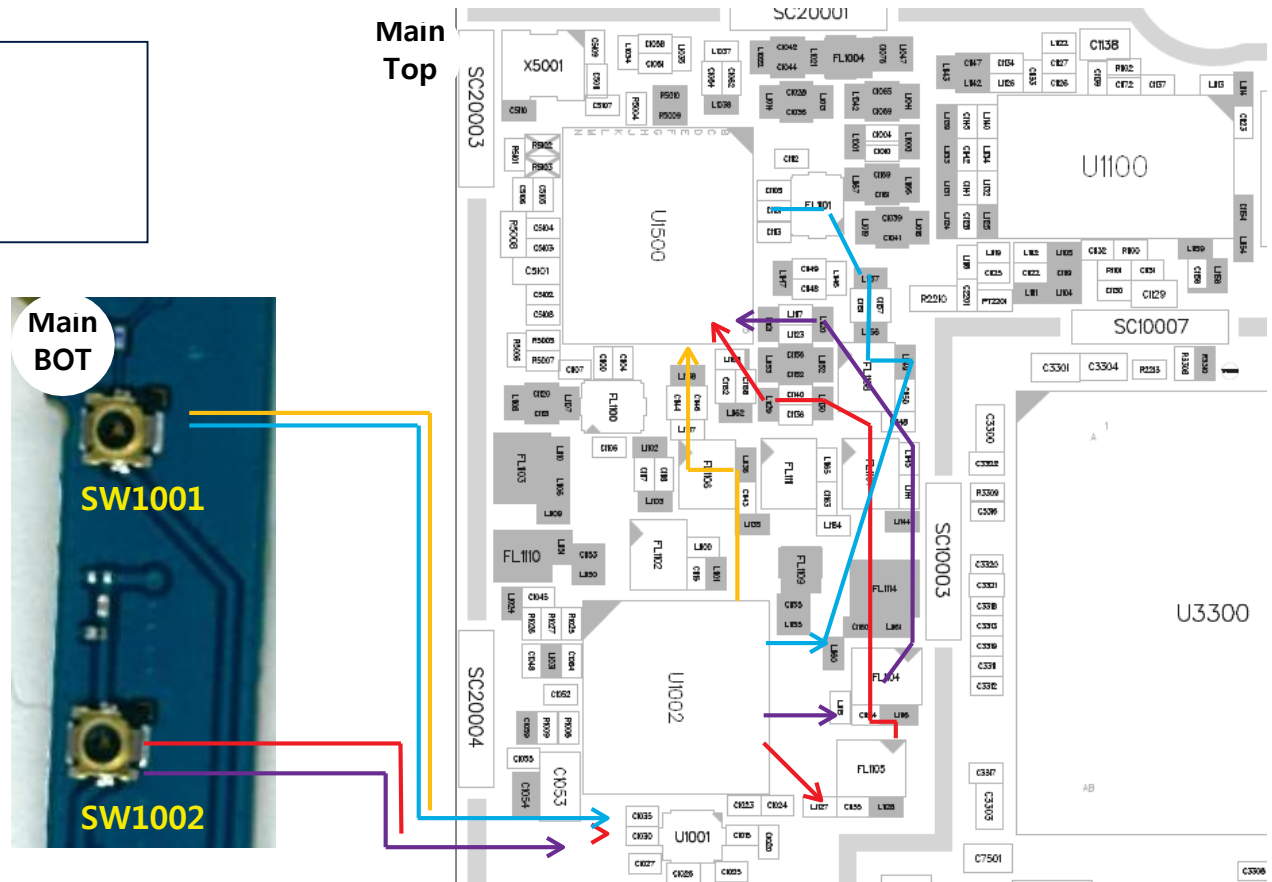

3. TROUBLE SHOOTING

3.6 WCDMA RF PART

3.6.2 Checking RF Signal RX path(SW, WCDMA B1)

Checking Flow

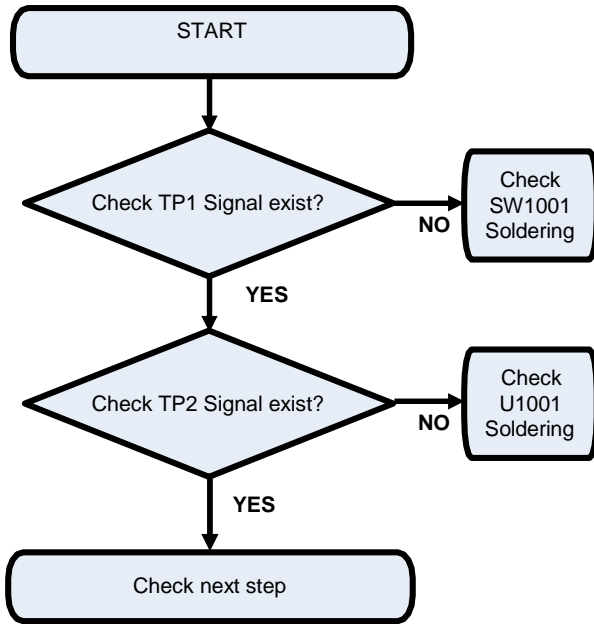

Image

Main Top



Circuit Diagram

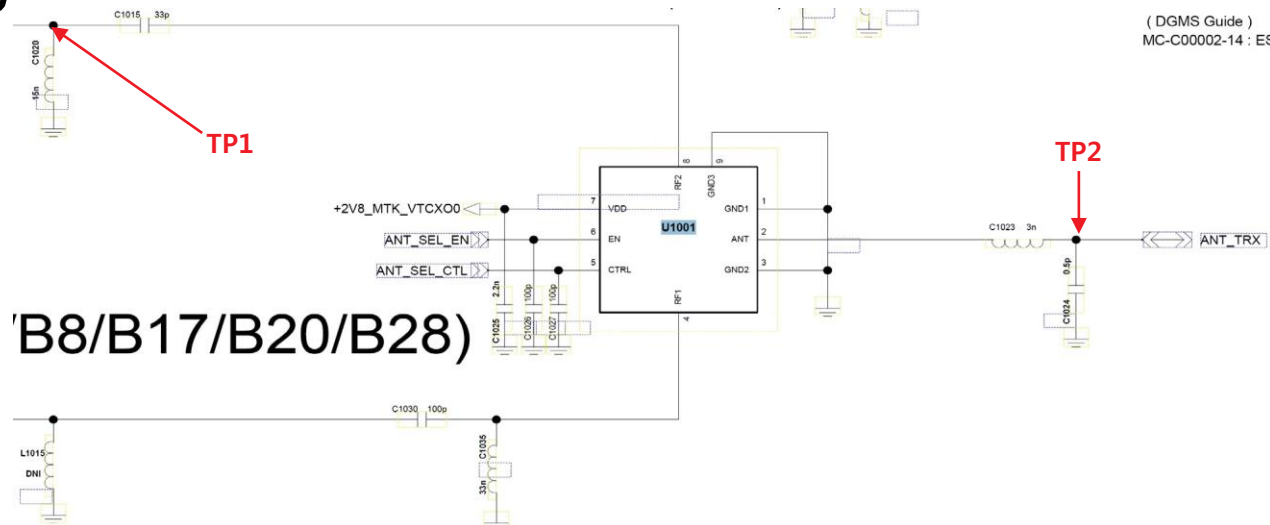

3.6 WCDMA RF PART

3.6.3 Checking RF Signal RX path(WCDMA B1)

Checking Flow

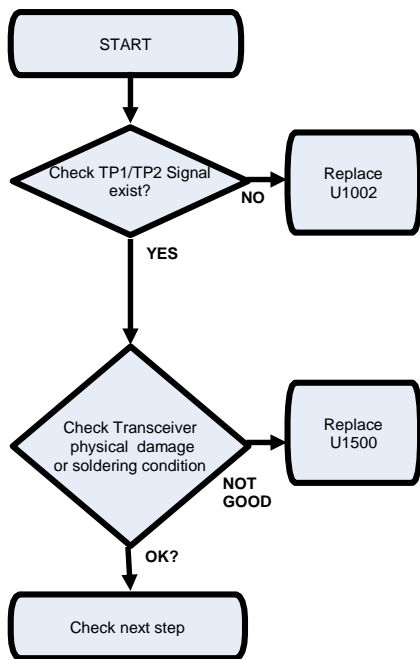

Image



Circuit Diagram

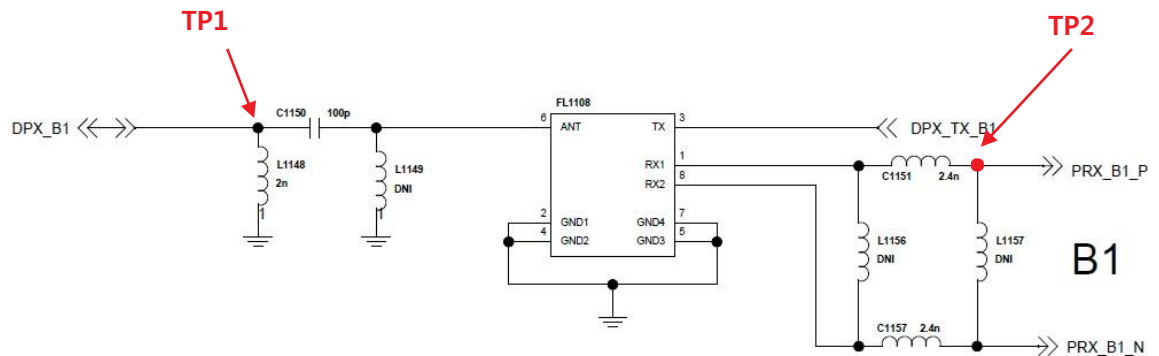

3. TROUBLE SHOOTING

3.6 WCDMA RF PART

3.6.4 Checking RF Signal RX path(SW, WCDMA B5/8)

Checking Flow

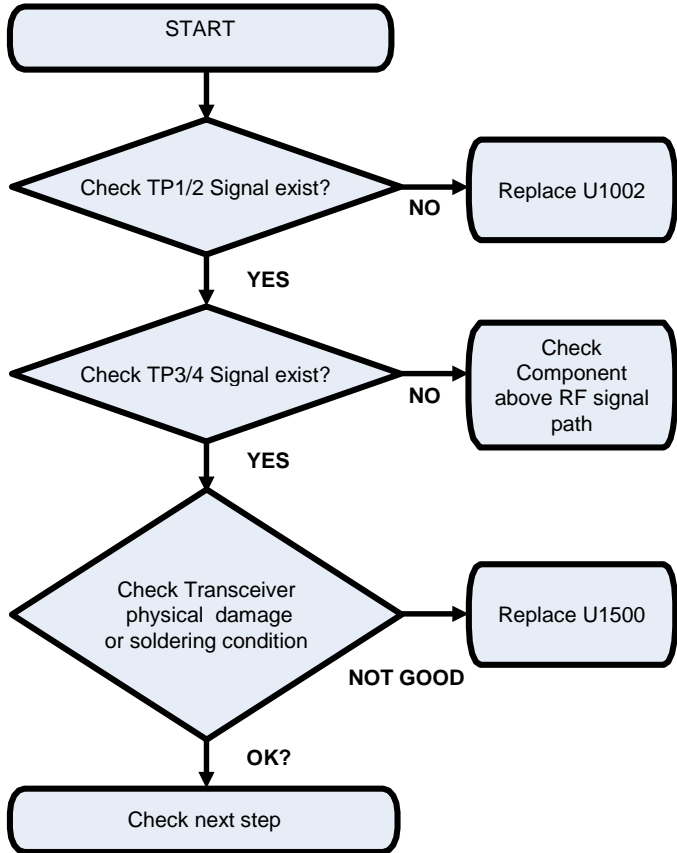

Image

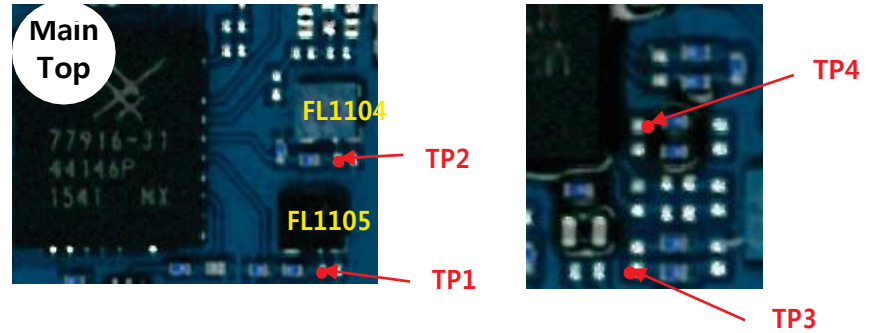

Circuit Diagram

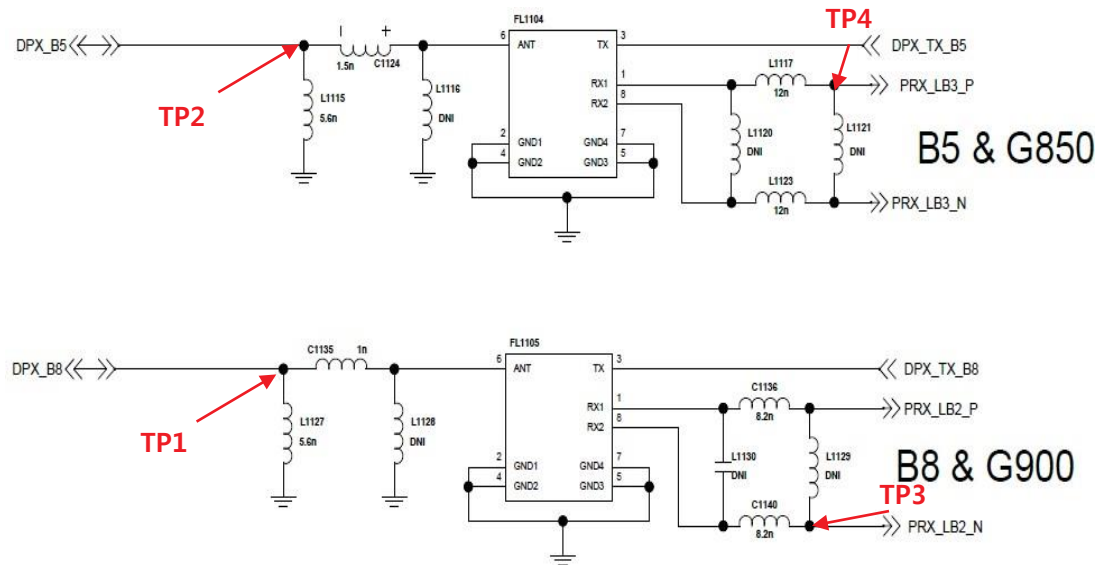

3. TROUBLE SHOOTING

3.6 WCDMA RF PART

3.6.5 WCDMA RF Part TX RF PATH

Image

1. WCDMA B5 TX PATH
2. WCDMA B8 TX PATH
3. WCDMA B1 TX PATH
4. WCDMA B2 TX PATH

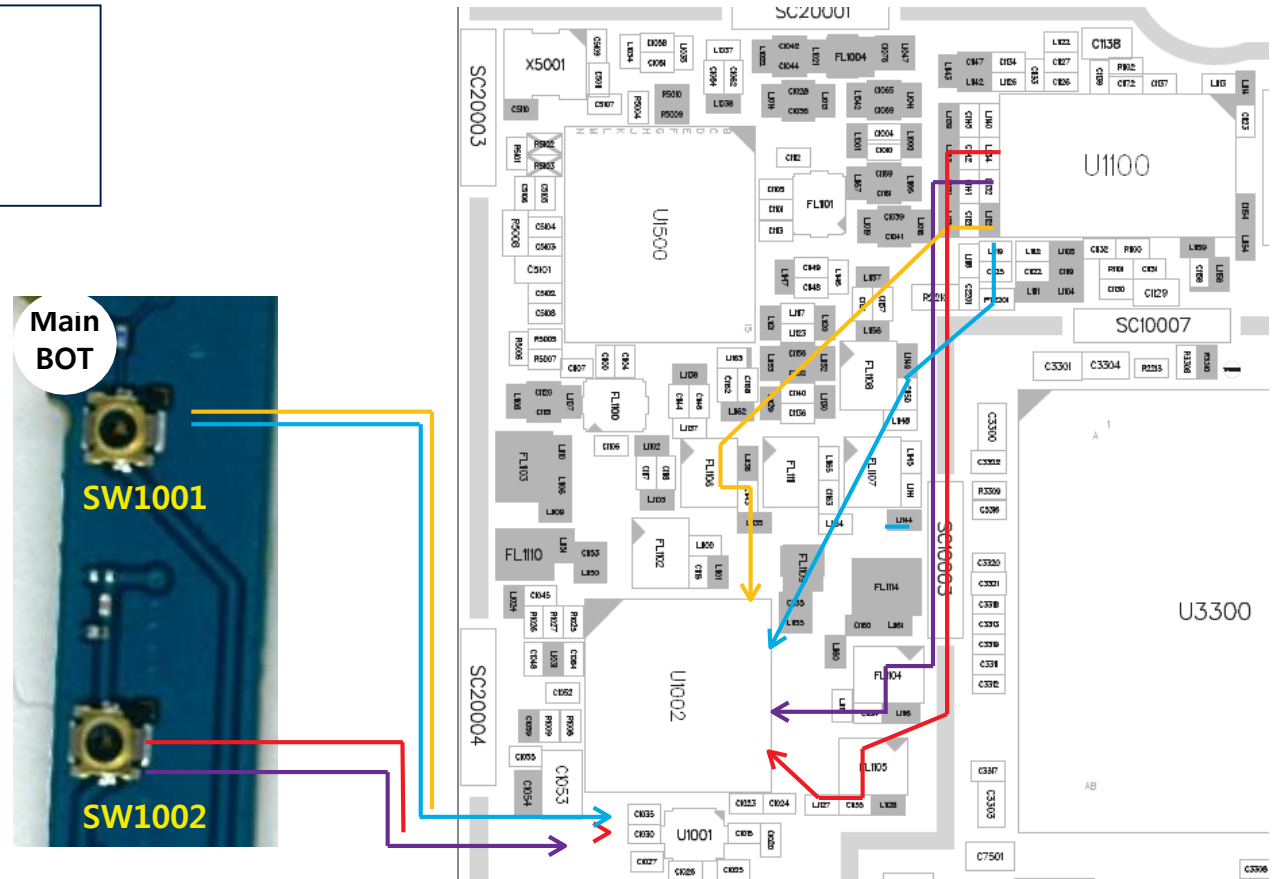

3. TROUBLE SHOOTING

3.6 WCDMA RF PART

3.6.6 Checking RF Signal TX path(SW, WCDMA B1)

Image

Checking Flow

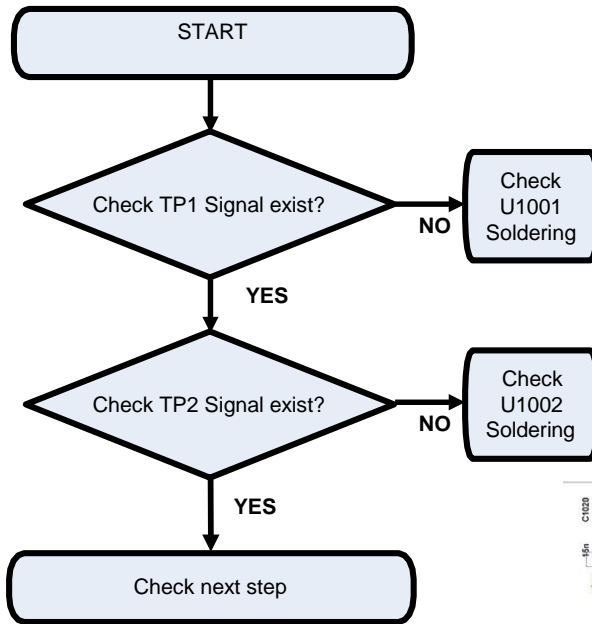

Circuit Diagram

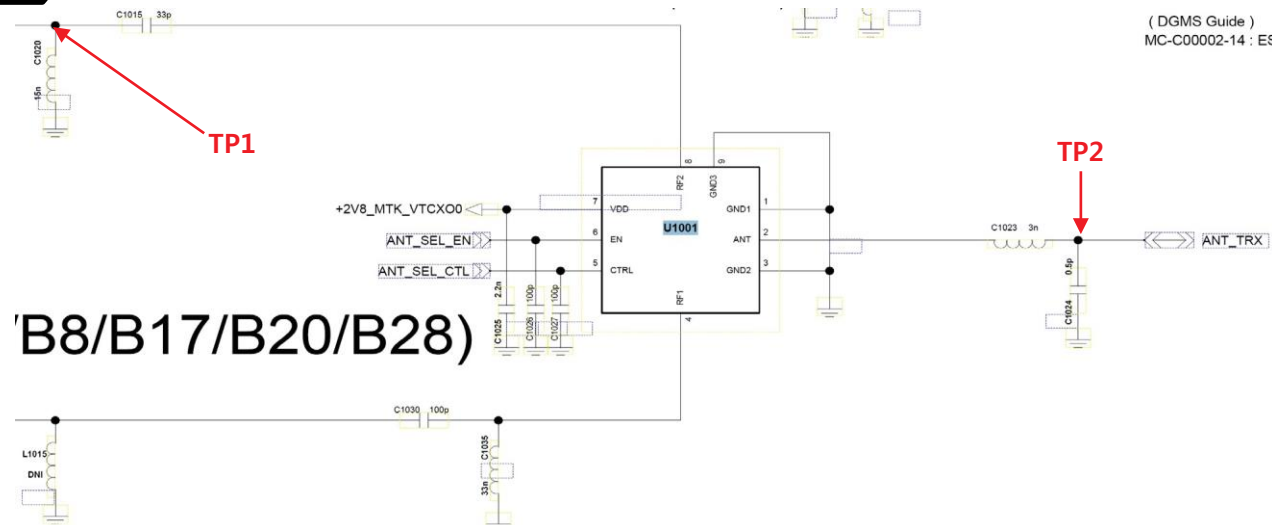

3.6 WCDMA RF PART

3.6.7 Checking RF Signal TX path(WCDMA B1)

Checking Flow

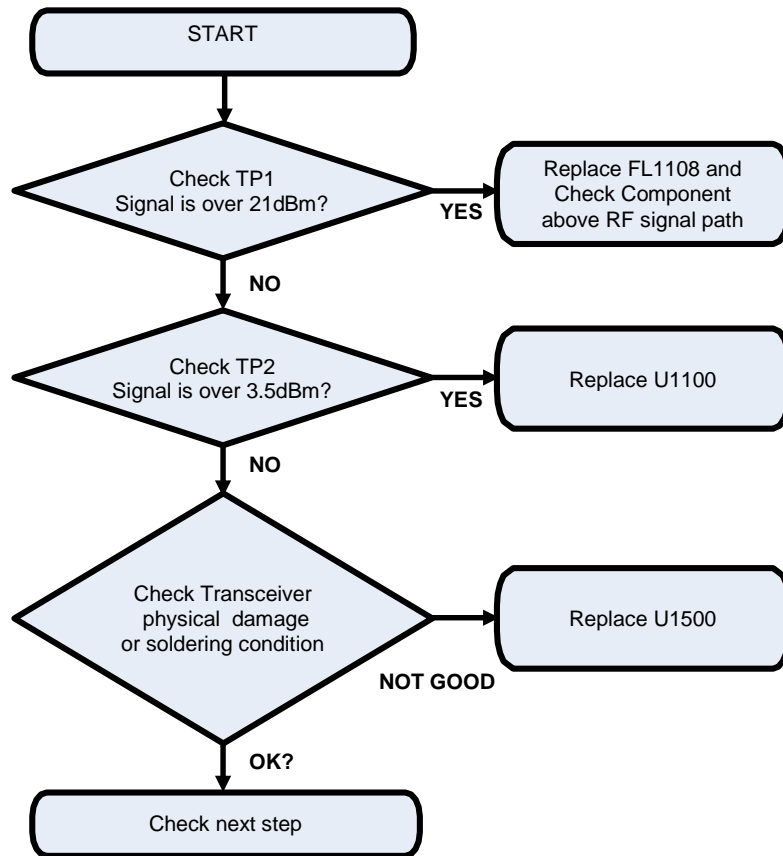

Image

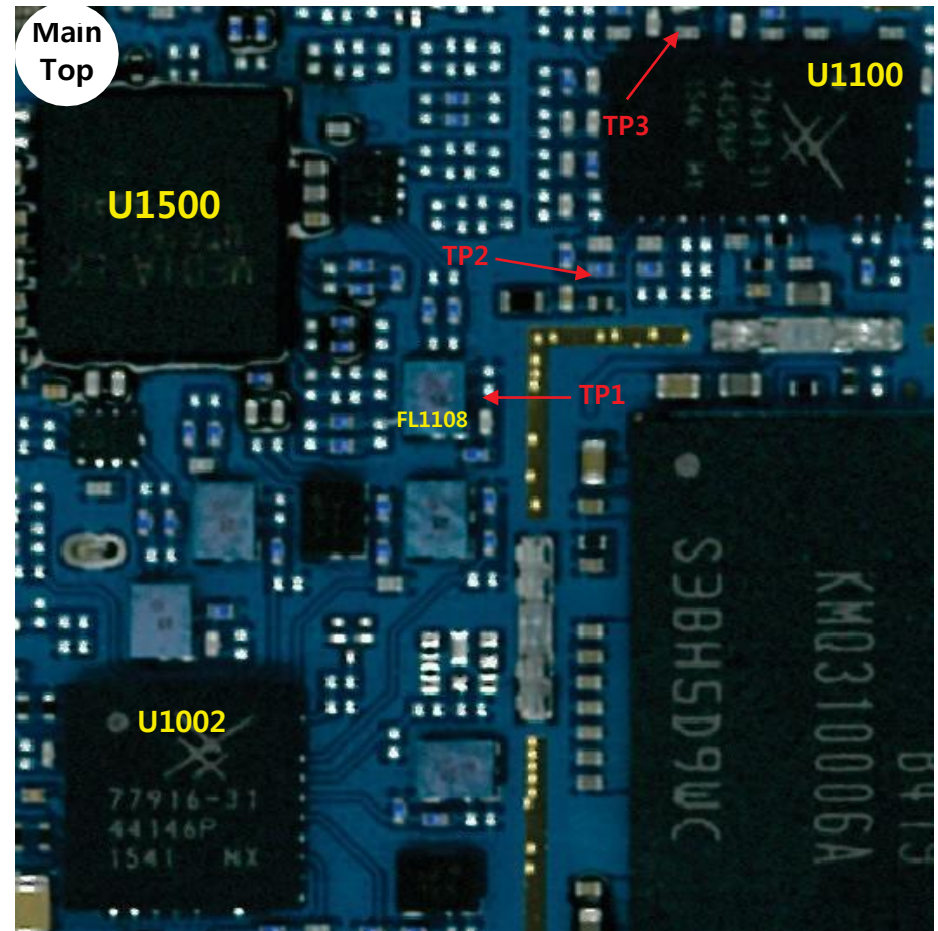

3.6 WCDMA RF PART

3.6.8 Checking RF Signal TX path(WCDMA B1)

Circuit Diagram

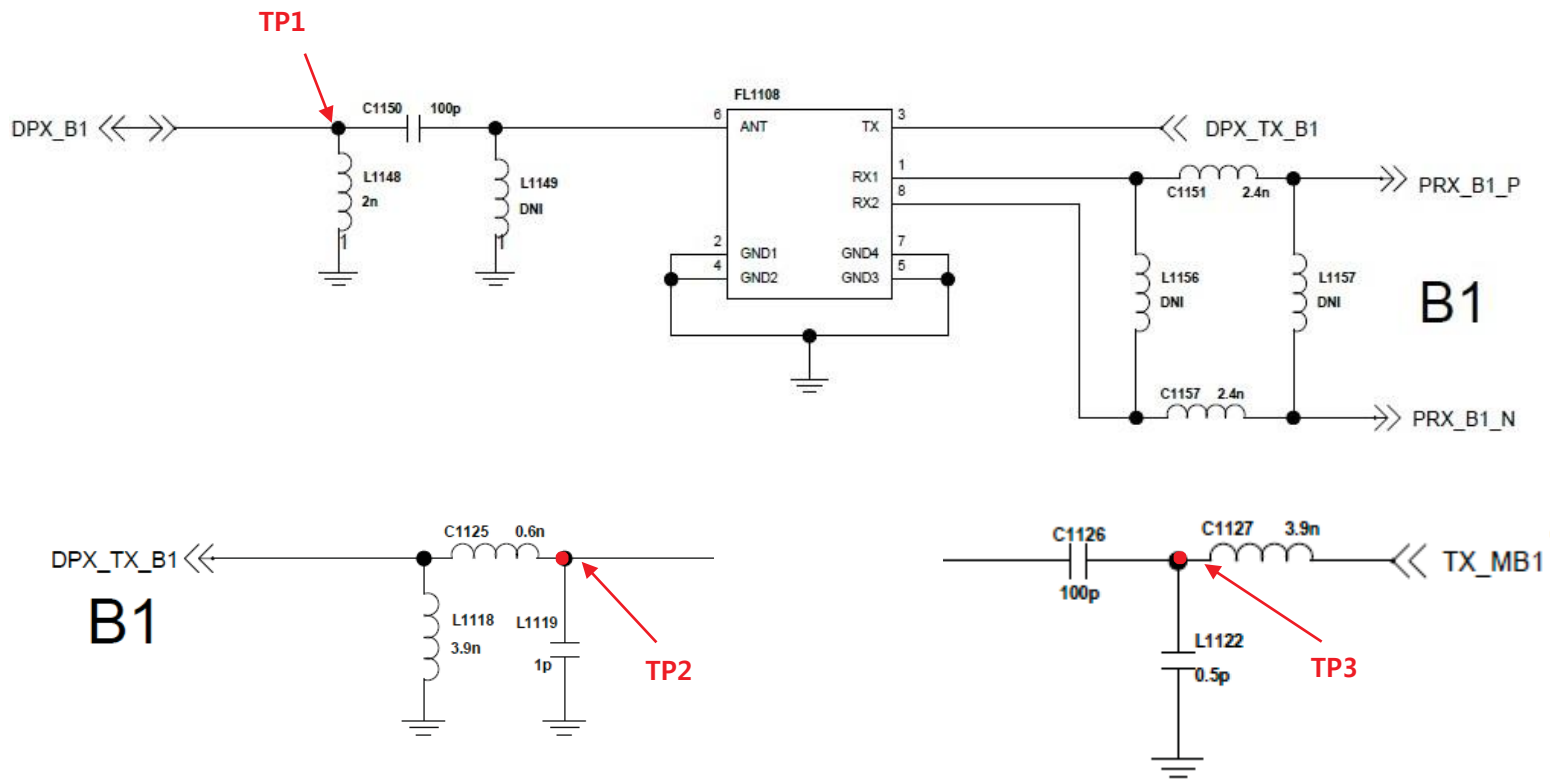

3. TROUBLE SHOOTING

3.6 WCDMA RF PART

3.6.9 Checking RF Signal TX path(SW, WCDMA B5/8)

Checking Flow

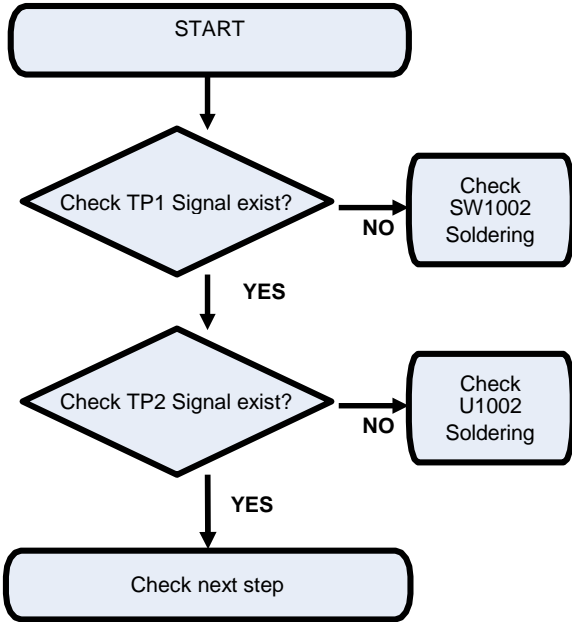

Main Top

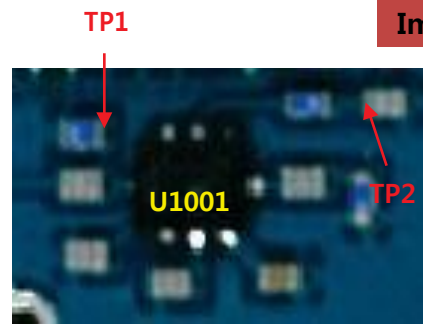

Image

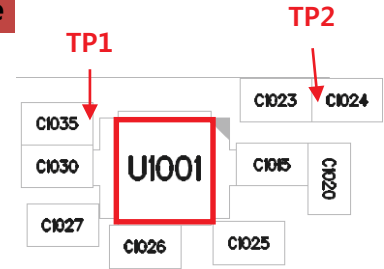

Circuit Diagram

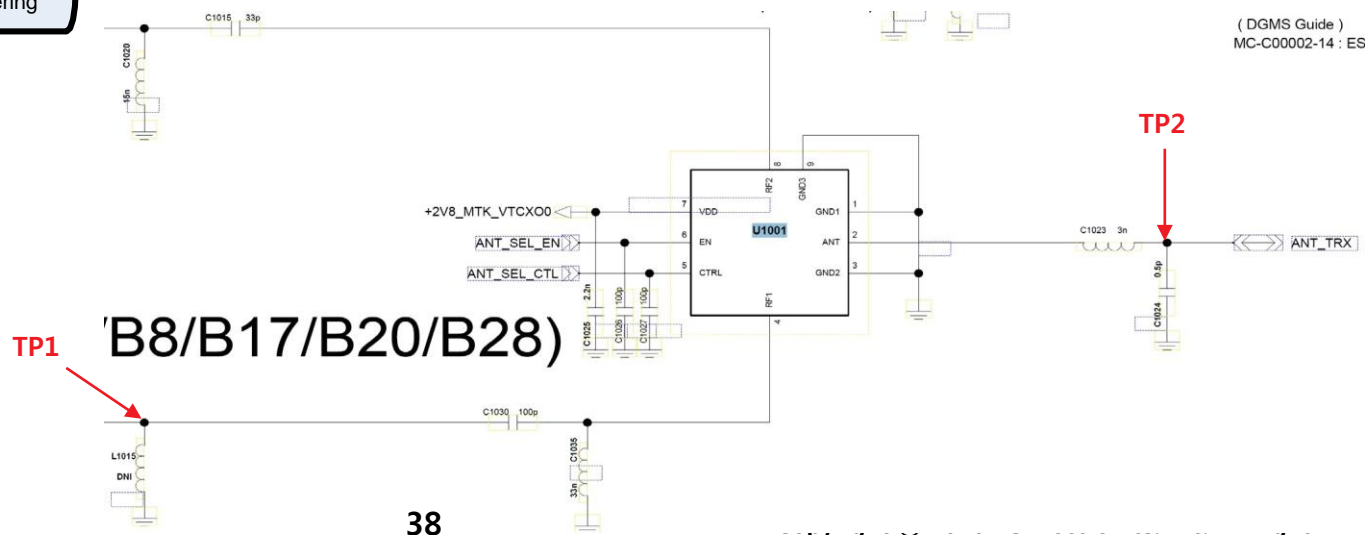

3.6 WCDMA RF PART

3.6.10 Checking RF Signal TX path(WCDMA B5/8)

Checking Flow

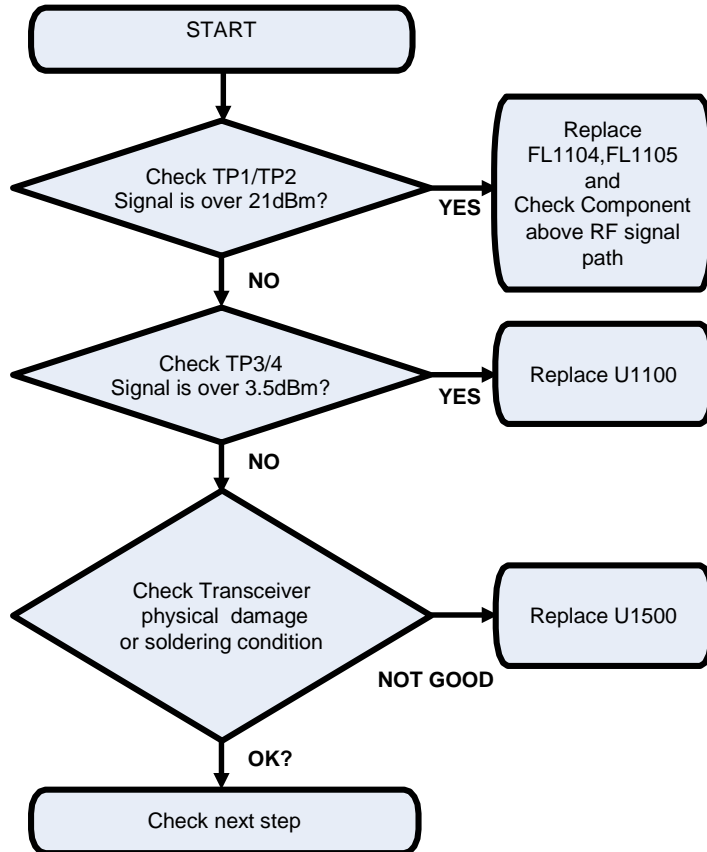

Image

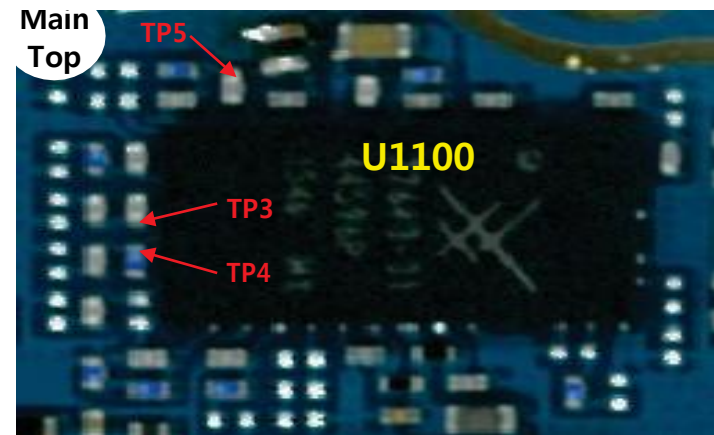
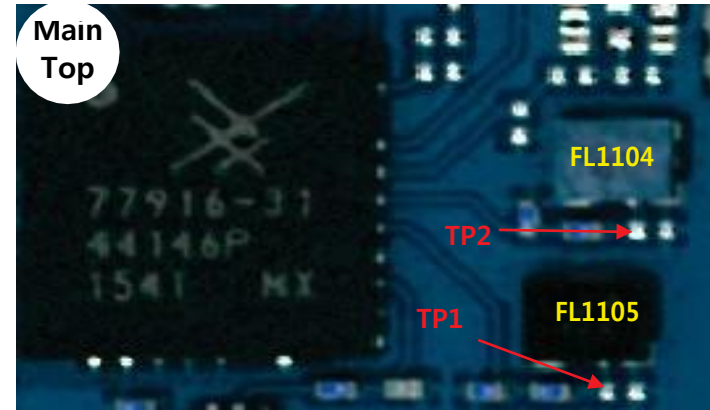

3.6 WCDMA RF PART

3.6.11 Checking RF Signal TX path(WCDMA B5/8)

Circuit Diagram

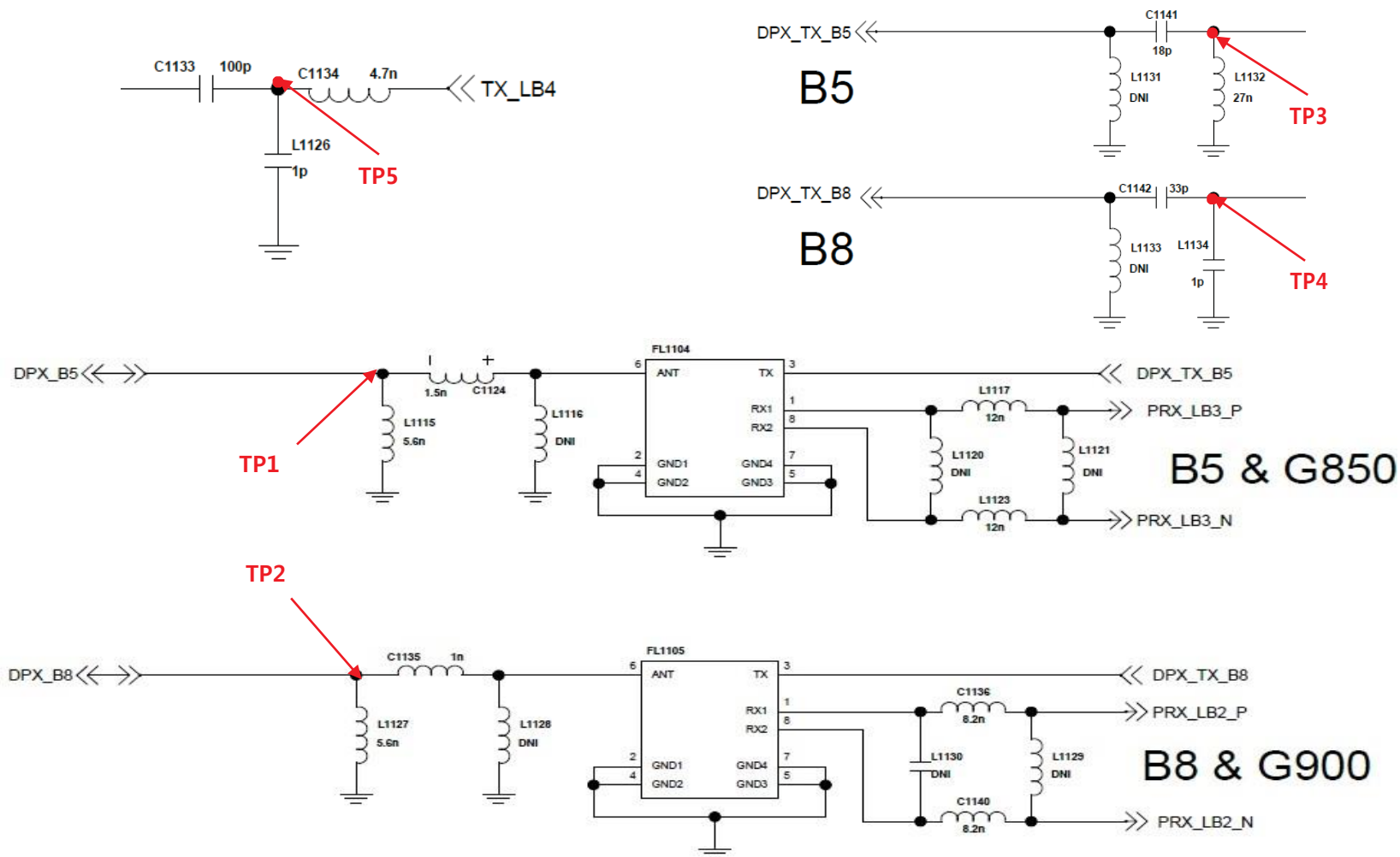

3.7 LTE RF PART

LTE RF Part support LTE B3/7/20 with ASM, PAM, Transceiver component

Checking Flow

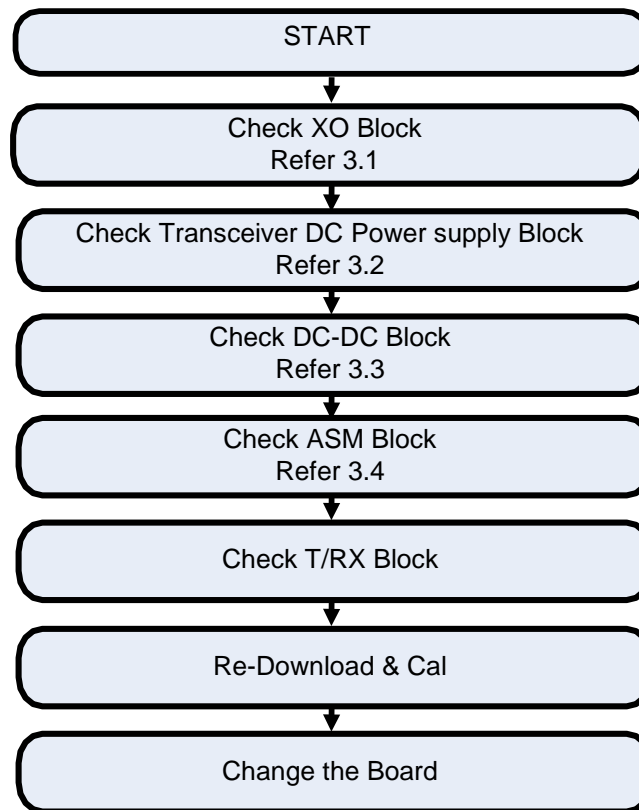

3.7 LTE RF PART

3.7.1 LTE RF Part RX RF PATH

Image

1. LTE B3 RX PATH
2. LTE B7 RX PATH
3. LTE B20 RX PATH

Main BOT

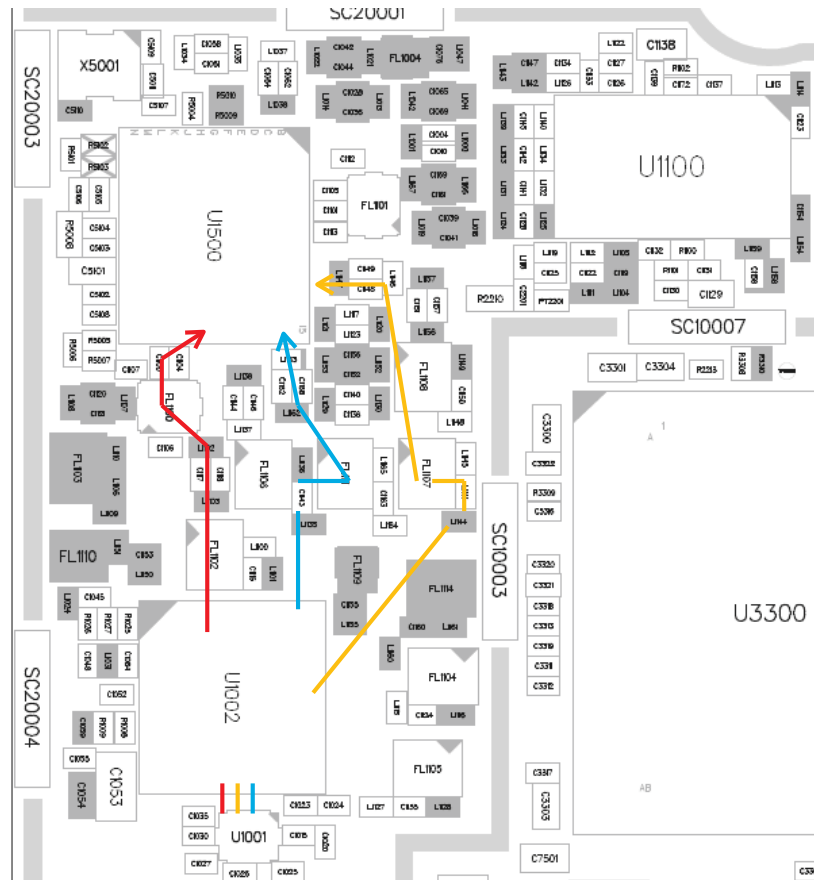

Main TOP

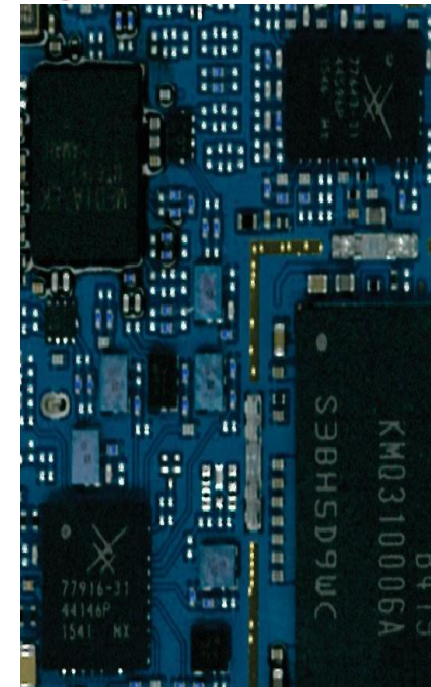

3. TROUBLE SHOOTING

3.7 LTE RF PART

3.7.2 Checking RF Signal RX path(SW, LTE B3)

Checking Flow

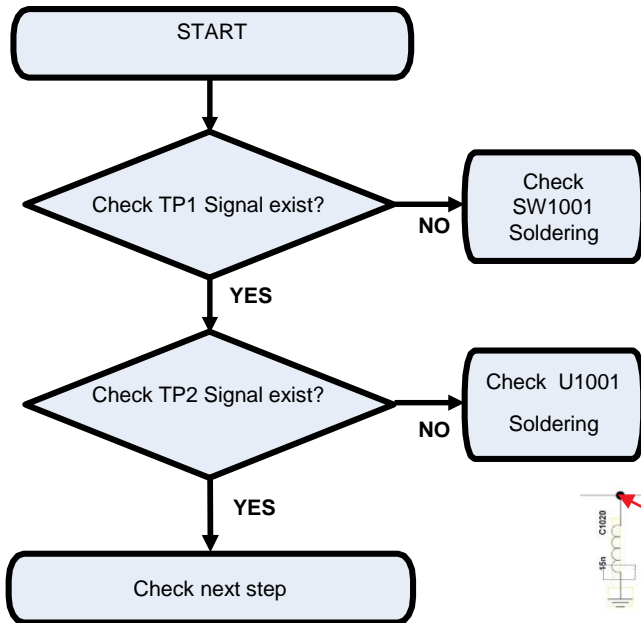

Image



Circuit Diagram

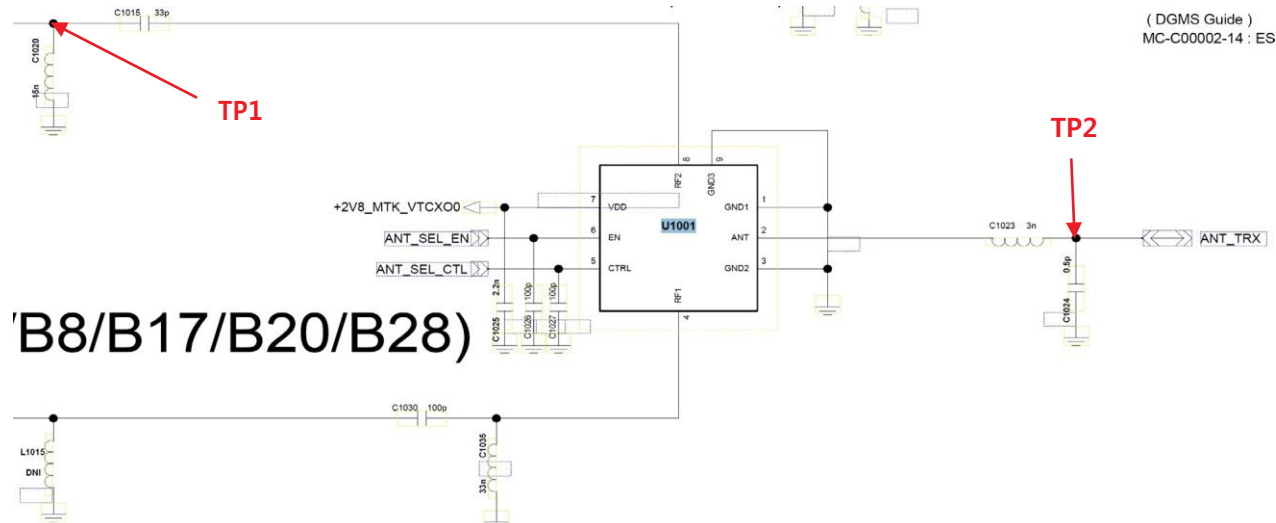

'B8/B17/B20/B28)

3. TROUBLE SHOOTING

3.7 LTE RF PART

3.7.3 Checking RF Signal RX path(LTE B3)

Checking Flow

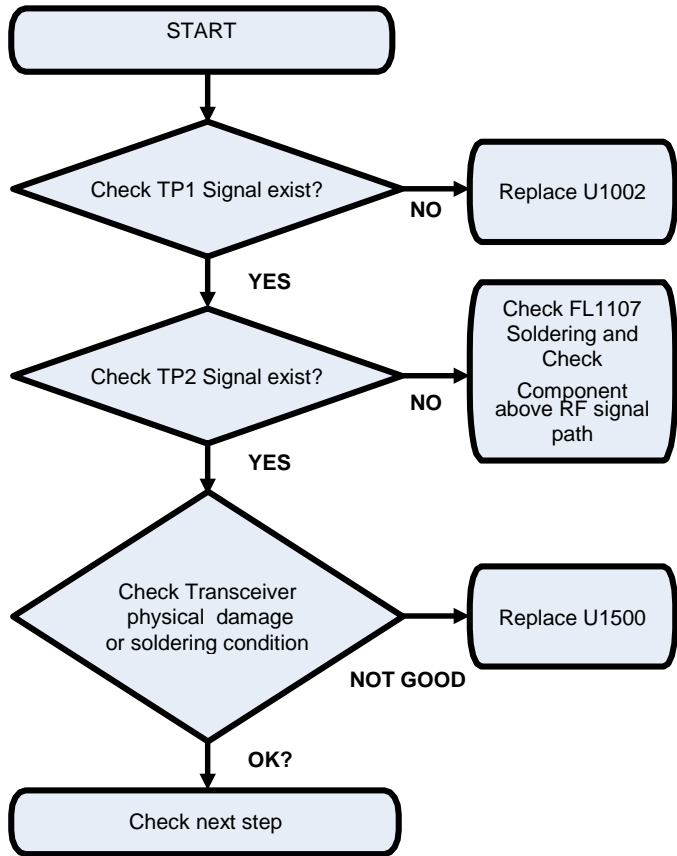

Image

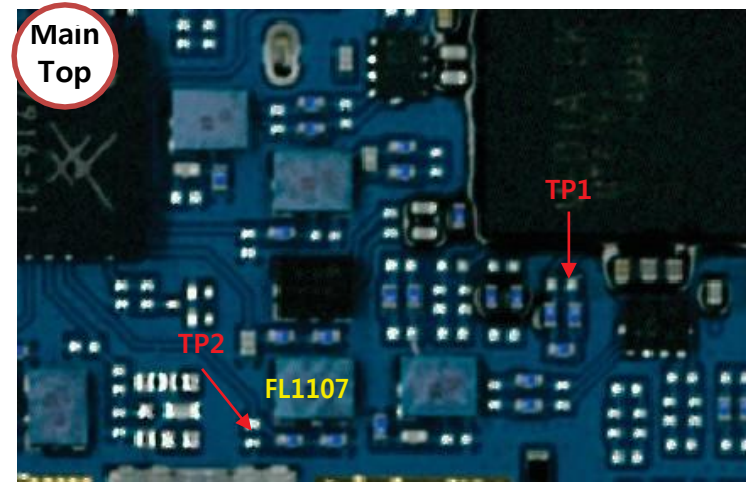

Circuit Diagram

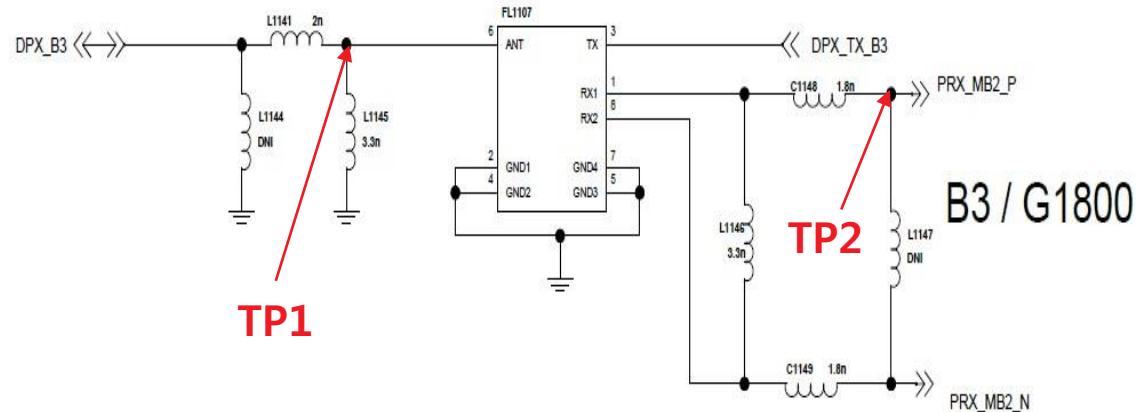

3. TROUBLE SHOOTING

3.7 LTE RF PART

3.7.4 Checking RF Signal RX path(SW, LTEB7/28)

Checking Flow

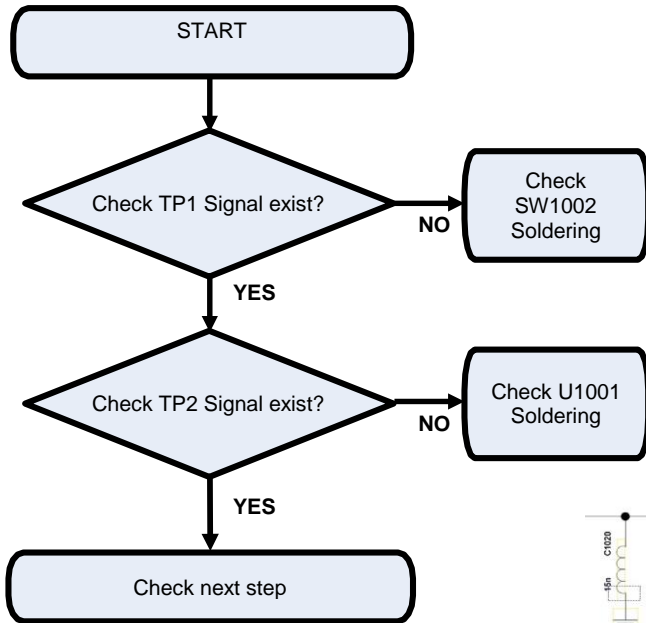

Main Top



Image

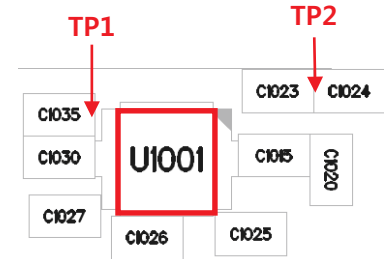

Circuit Diagram

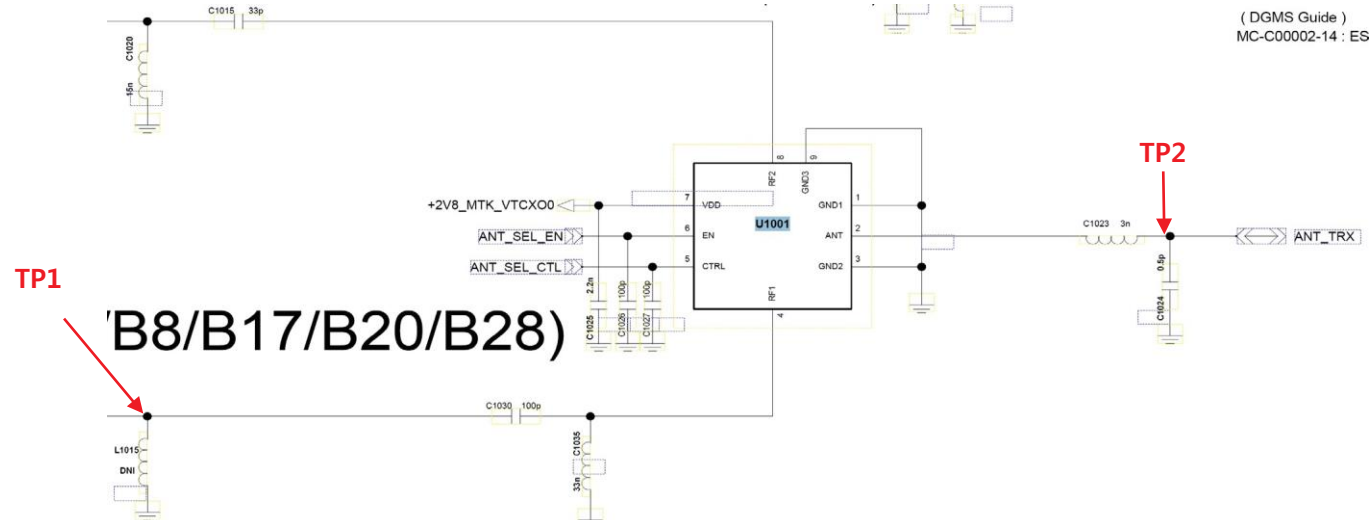

3. TROUBLE SHOOTING

3.7 LTE RF PART

3.7.5 Checking RF Signal RX path(LTE B7)

Checking Flow

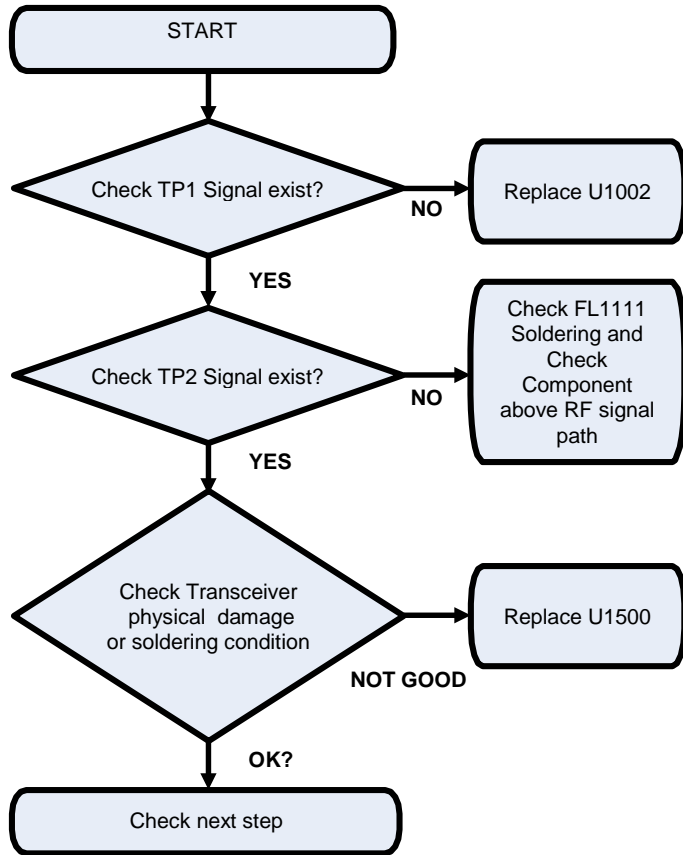

Image

Main Top

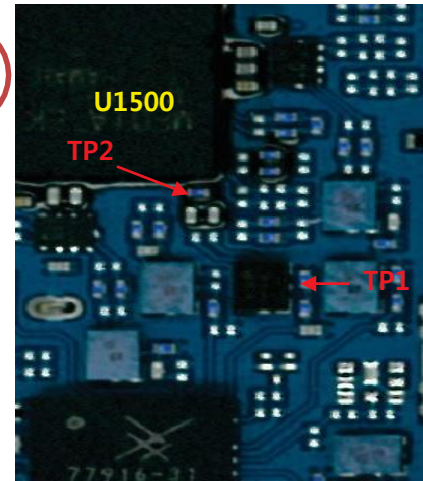

Circuit Diagram

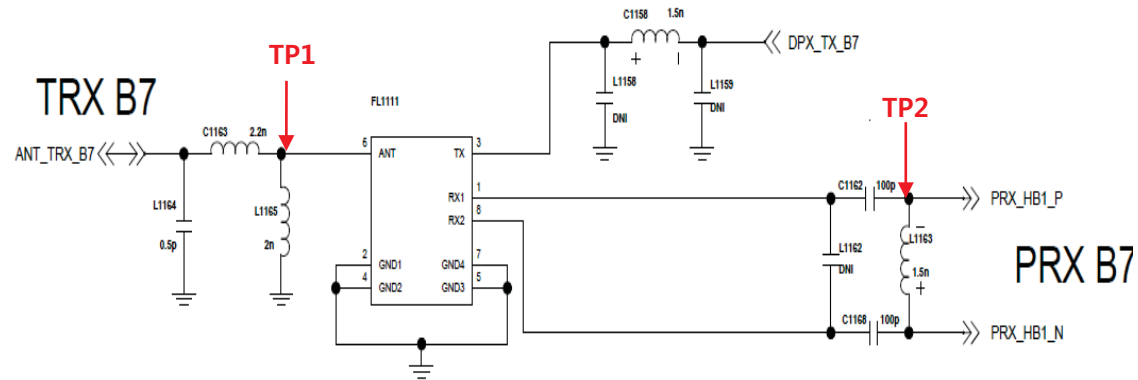

3. TROUBLE SHOOTING

3.7 LTE RF PART

3.7.6 Checking RF Signal RX path(LTE B28A)

Checking Flow

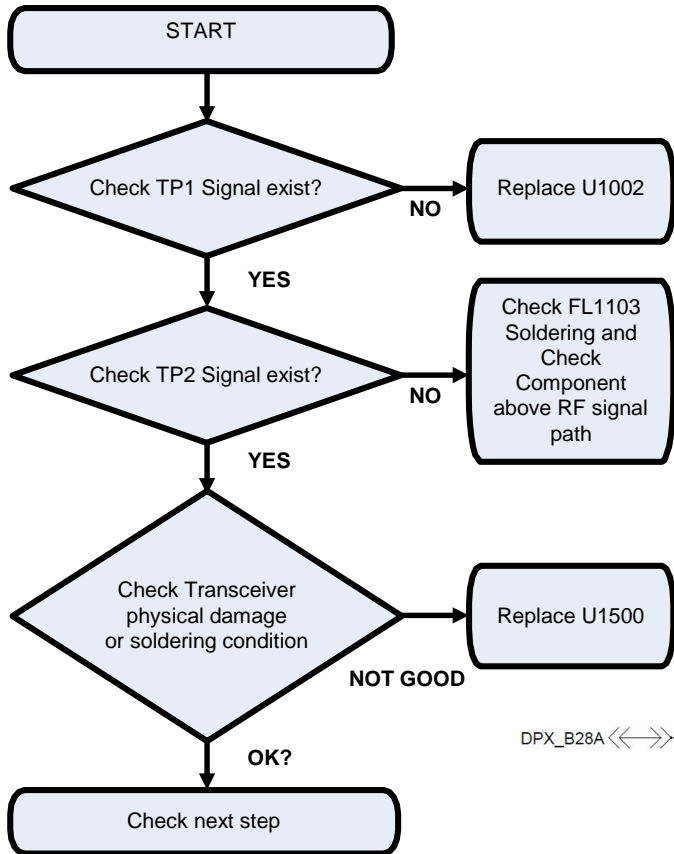

Main Top

Image

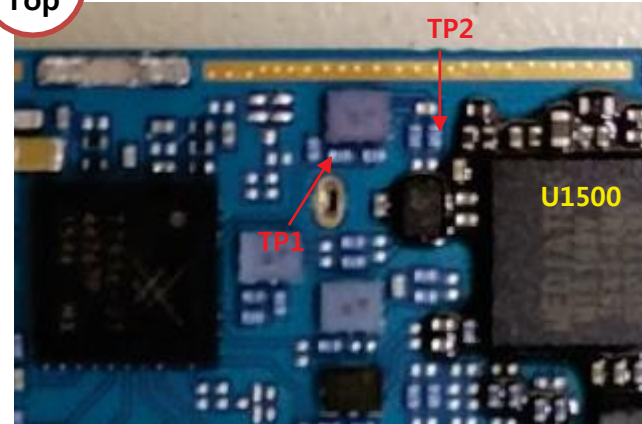

Circuit Diagram

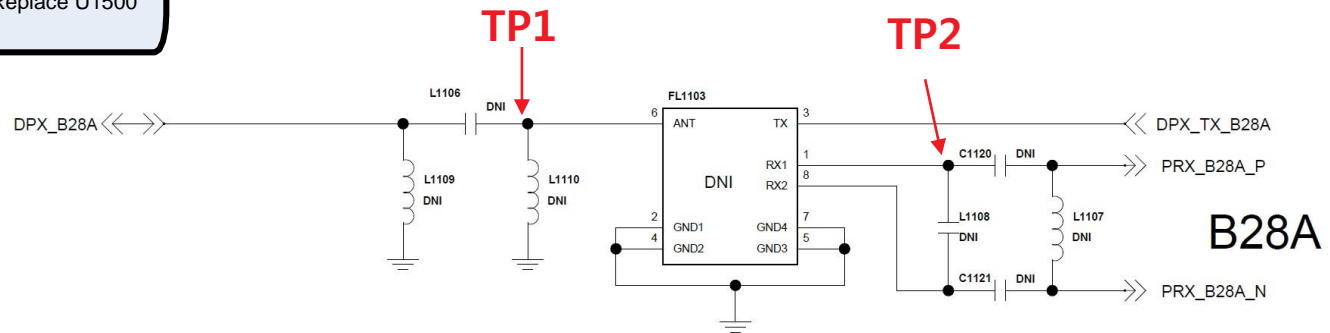

3. TROUBLE SHOOTING

3.7 LTE RF PART

3.7.6 Checking RF Signal RX path(LTE B28B)

Checking Flow

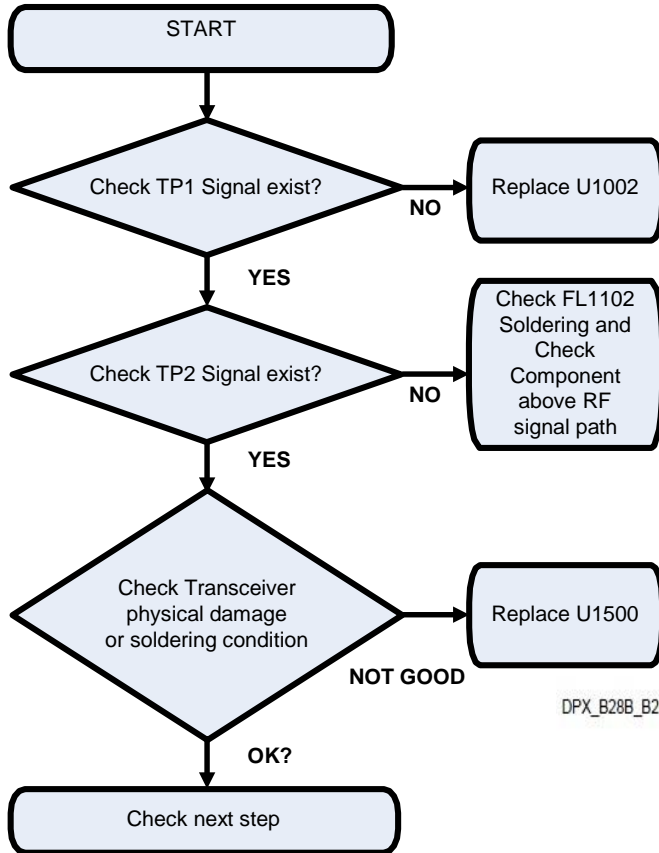

Image

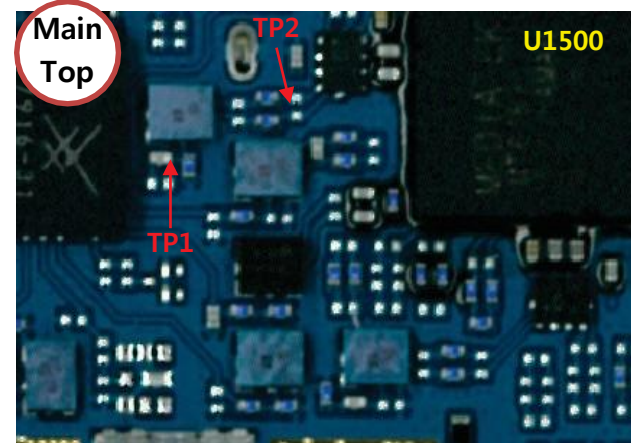

Circuit Diagram

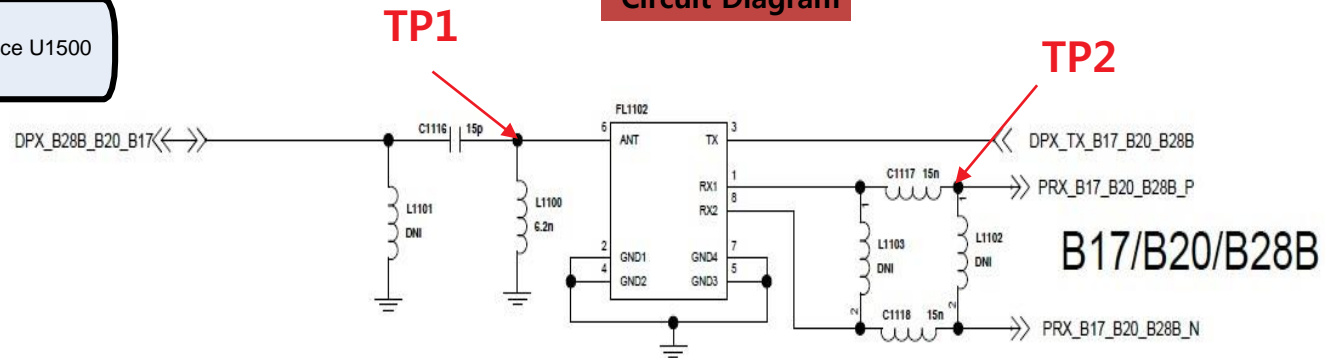

3.7 LTE RF PART

3.7.7 LTE RF Part DRX RF PATH

Image

1. LTE B3 DRX PATH
2. LTE B7 DRX PATH
3. LTE B28 DRX PATH

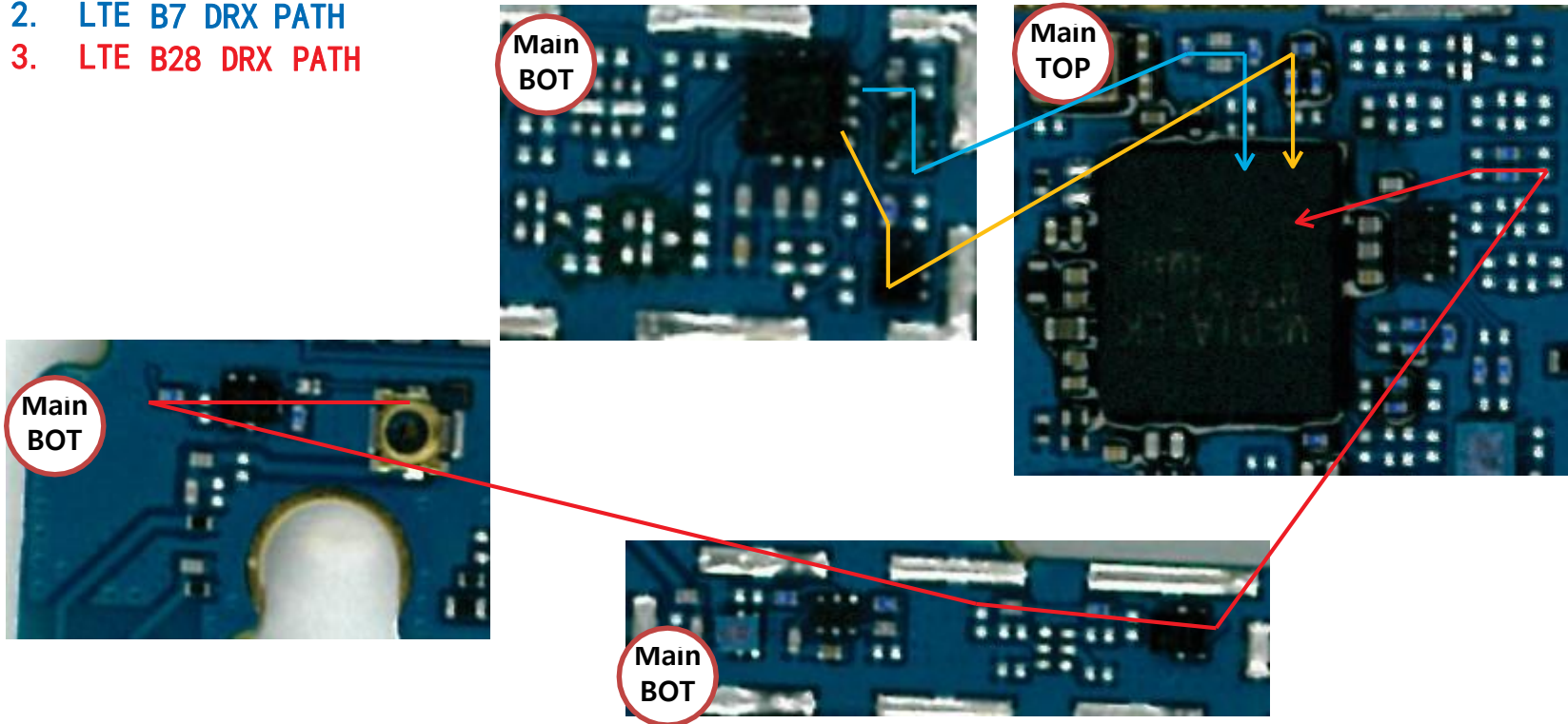

3. TROUBLE SHOOTING

3.7 LTE RF PART

3.7.8 Checking RF Signal DRX path(LTEB3/B7/B20)

Checking Flow

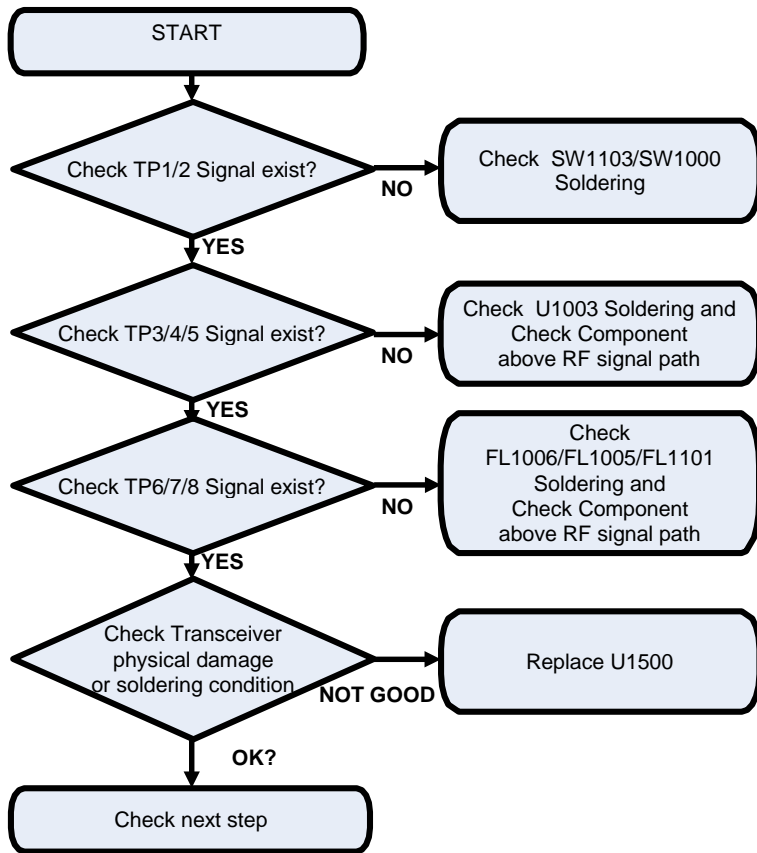

Image

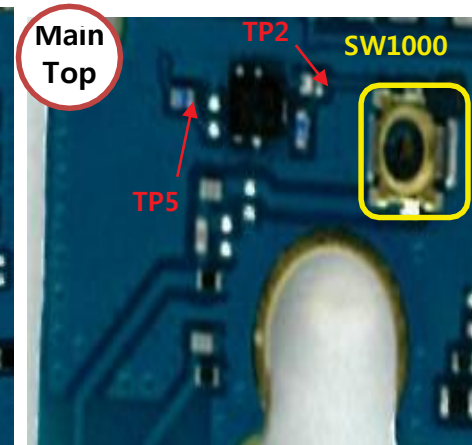
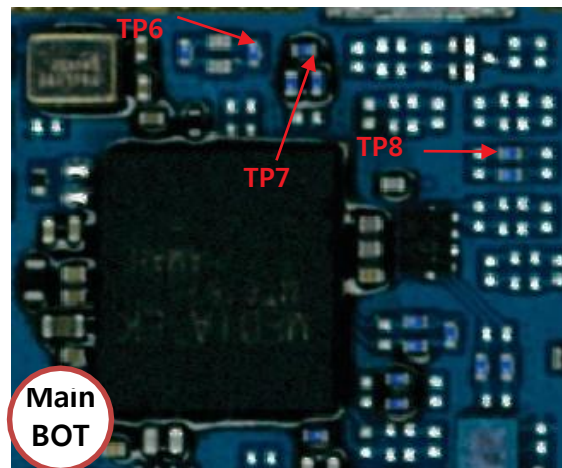
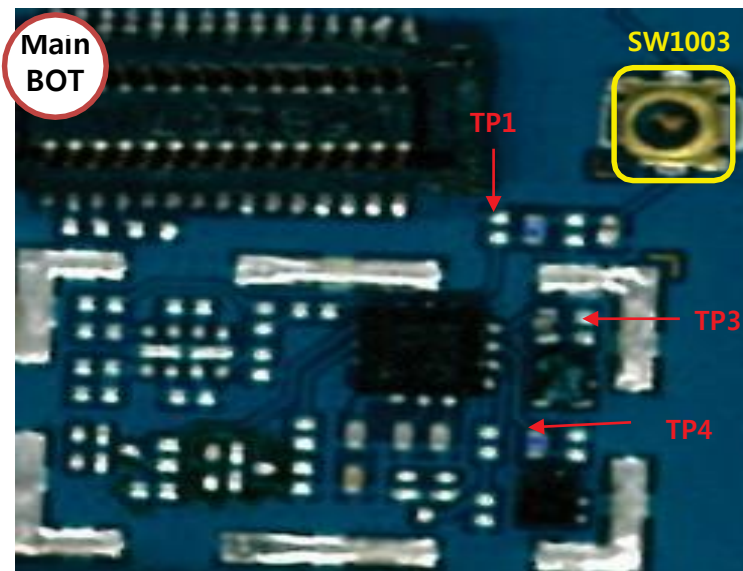

3.7 LTE RF PART

3.7.8 Checking RF Signal DRX path(LTEB3/B7/B20)

Circuit Diagram

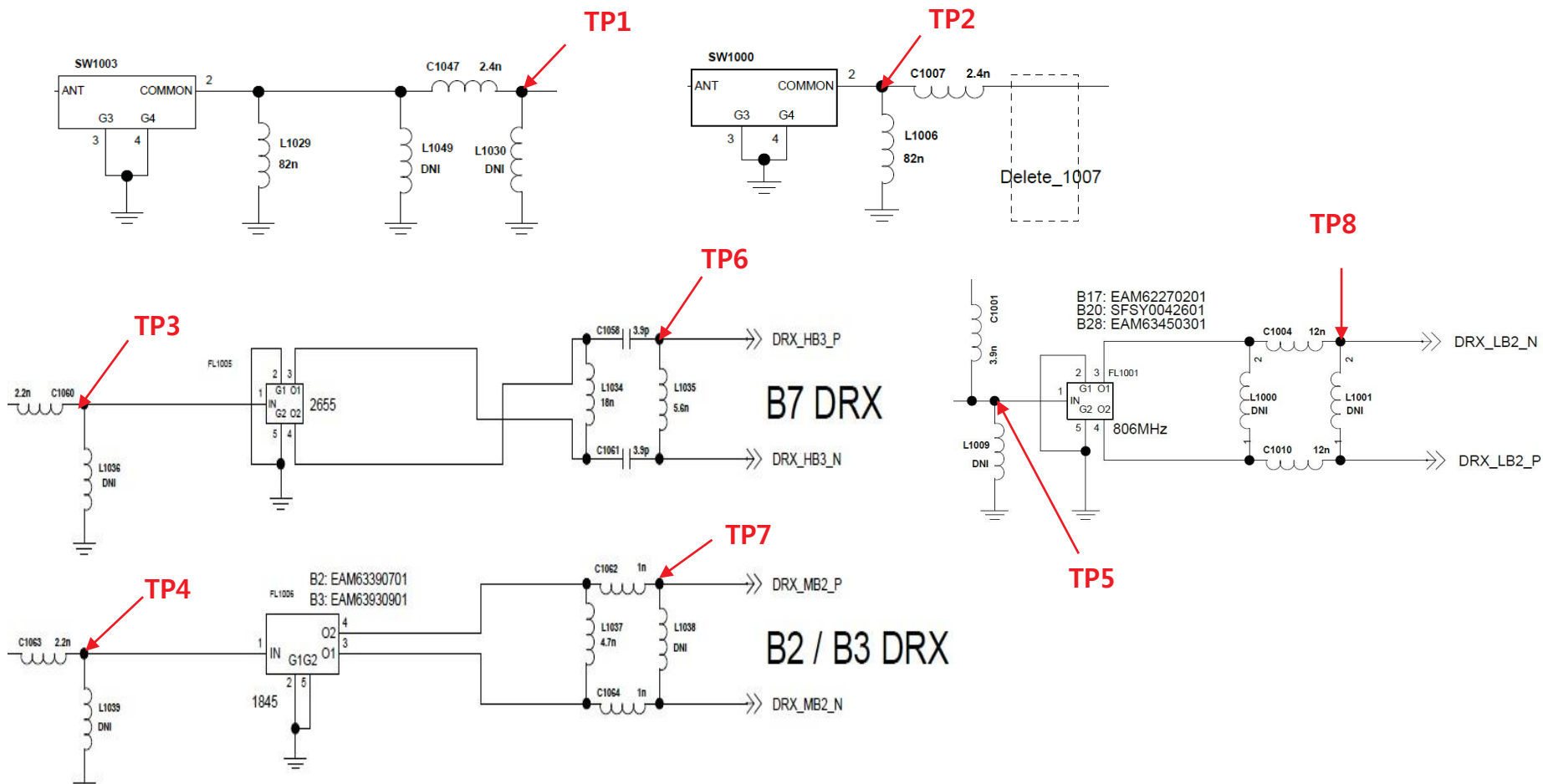

3.7 LTE RF PART

3.7.9 LTE RF Part TX RF PATH

Image

1. LTE B3 TX PATH
2. LTE B7 TX PATH
3. LTE B28 TX PATH

Main
BOT

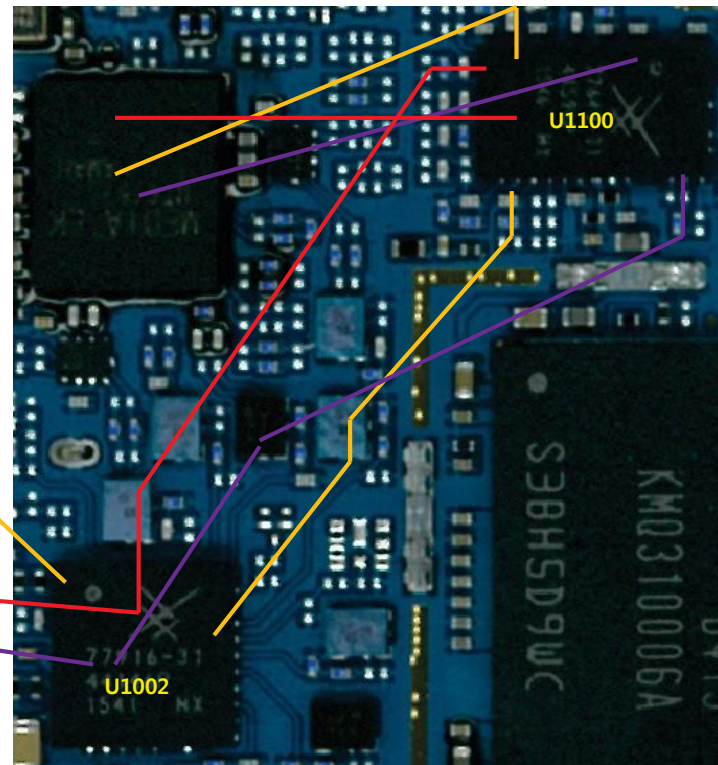
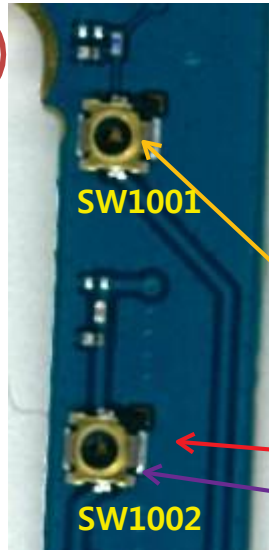

Main
Top

3. TROUBLE SHOOTING

3.7 LTE RF PART

3.7.10 Checking RF Signal TX path(SW, LTE B3)

Checking Flow

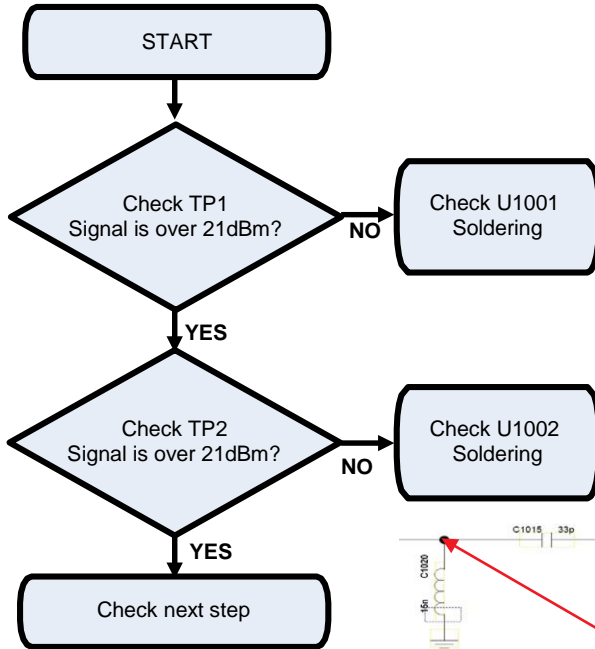

Image



Circuit Diagram

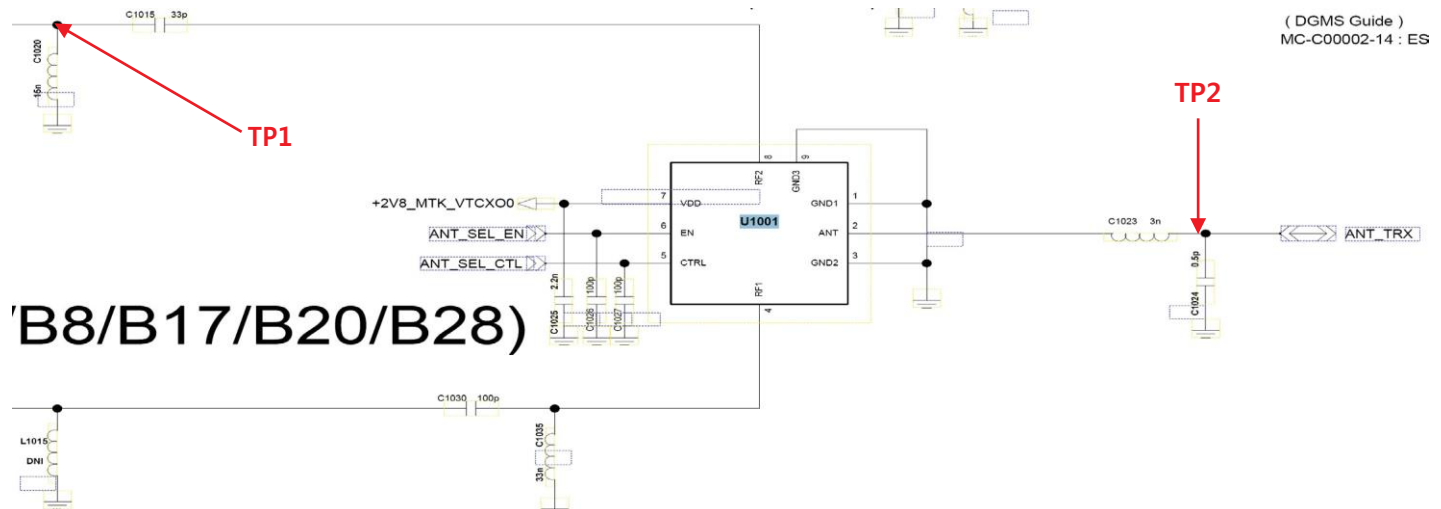

3. TROUBLE SHOOTING

3.7 LTE RF PART

3.7.11 Checking RF Signal TX path(LTE B3)

Checking Flow

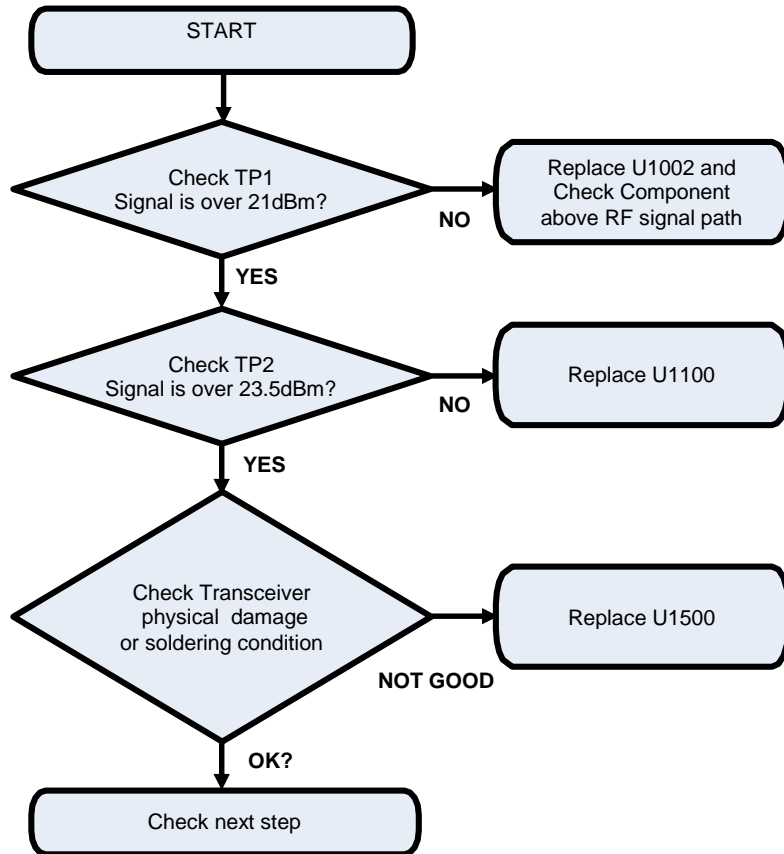

Image

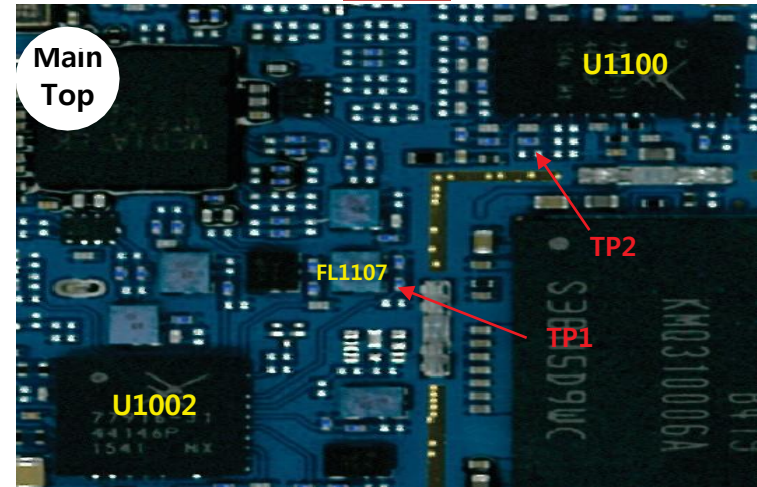

Circuit Diagram

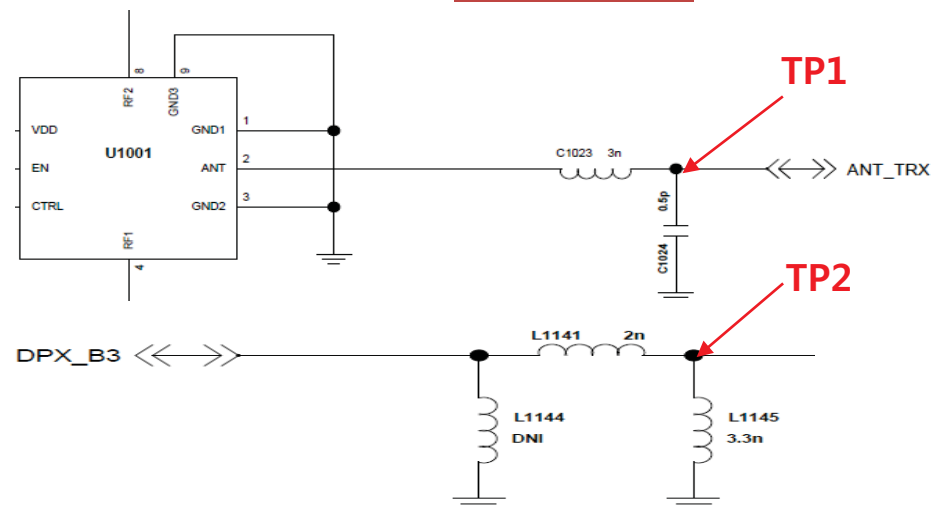

3. TROUBLE SHOOTING

3.7 LTE RF PART

3.7.12 Checking RF Signal TX path(SW, LTE B7/B28)

Checking Flow

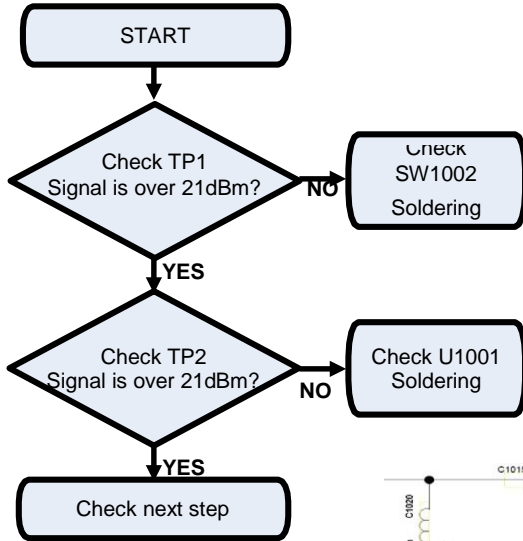

Image

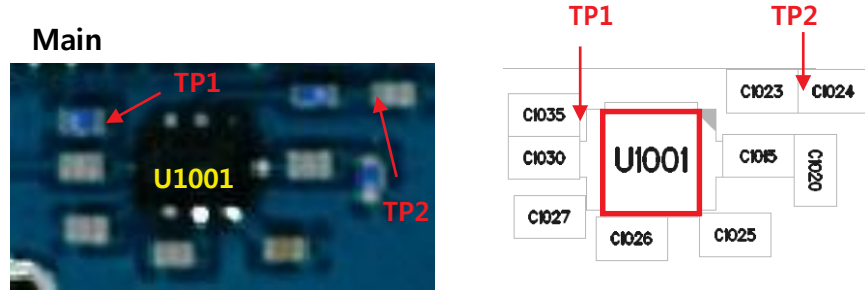

Circuit Diagram

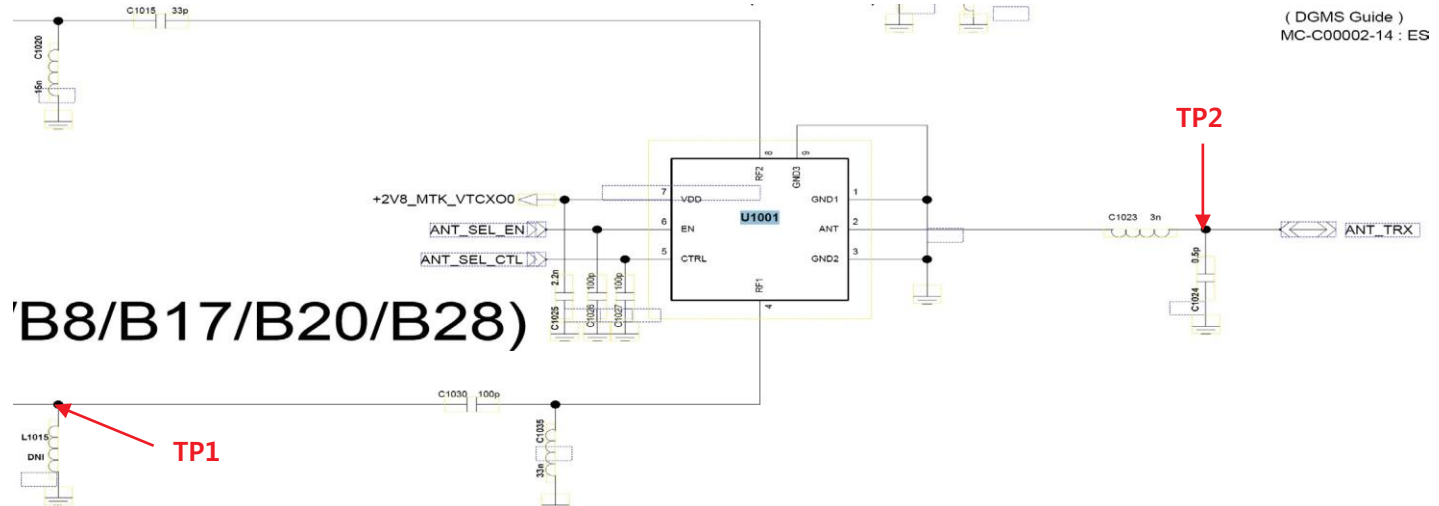

3. TROUBLE SHOOTING

3.7 LTE RF PART

3.7.13 Checking RF Signal TX path(LTE B7)

Checking Flow

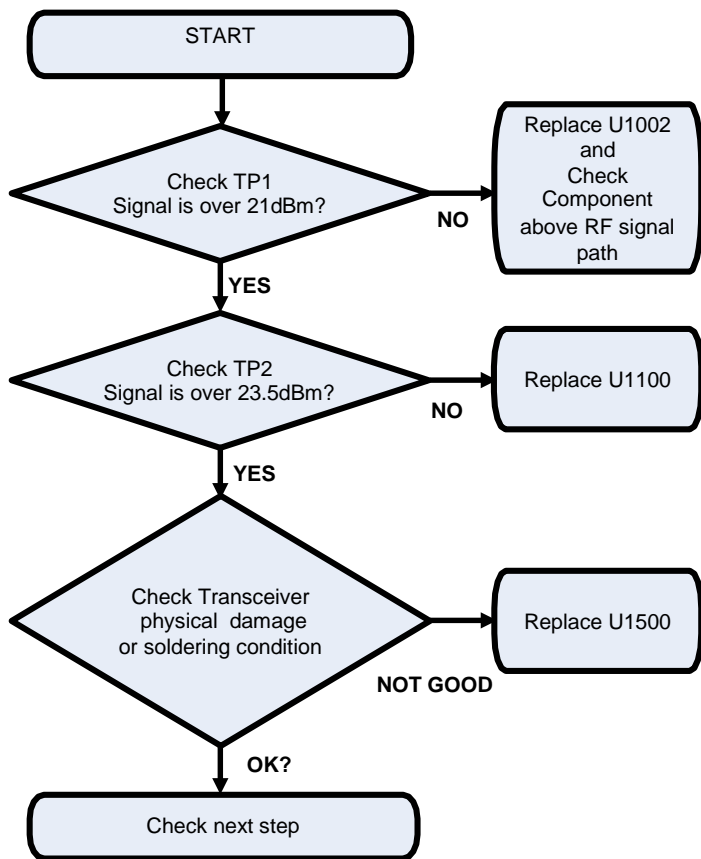

Image

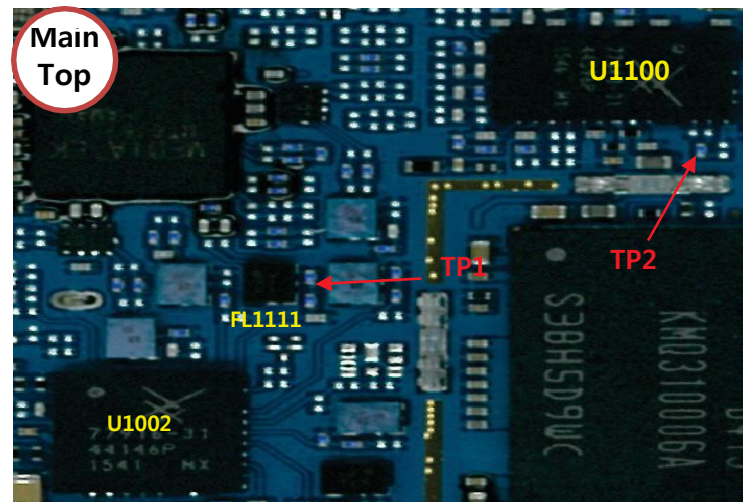

Circuit Diagram

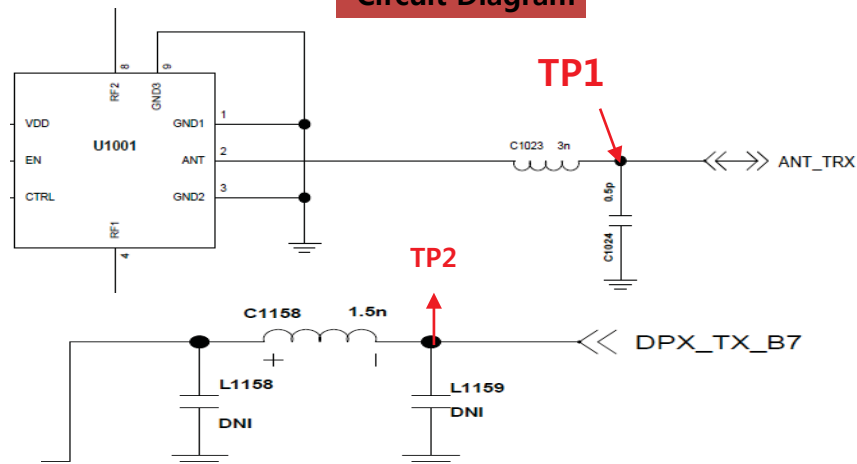

3.7 LTE RF PART

3.7.14 Checking RF Signal TX path(LTE B28A)

Checking Flow

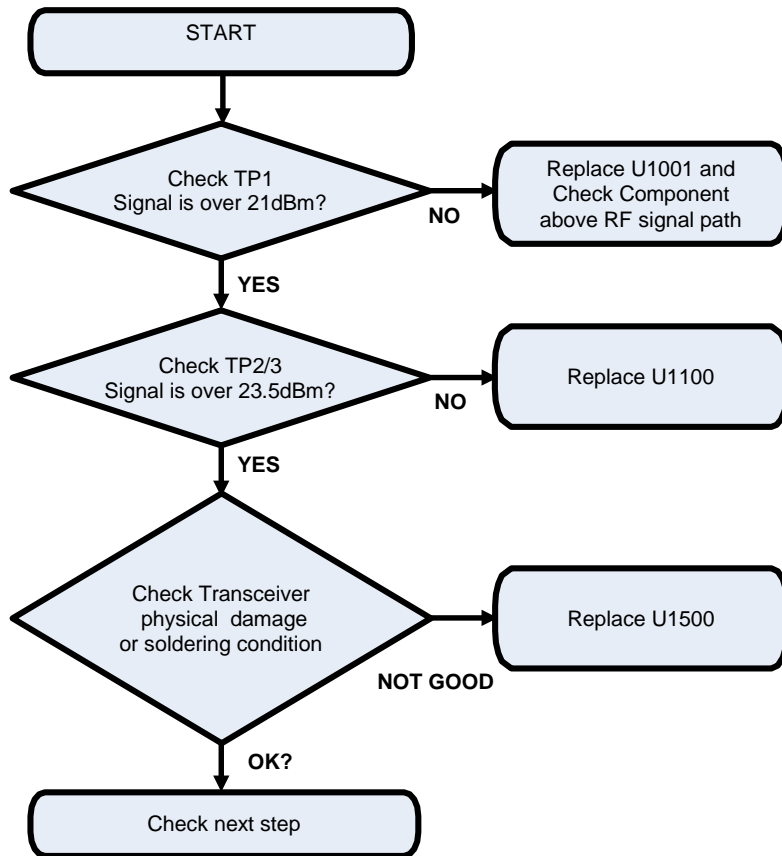

Image

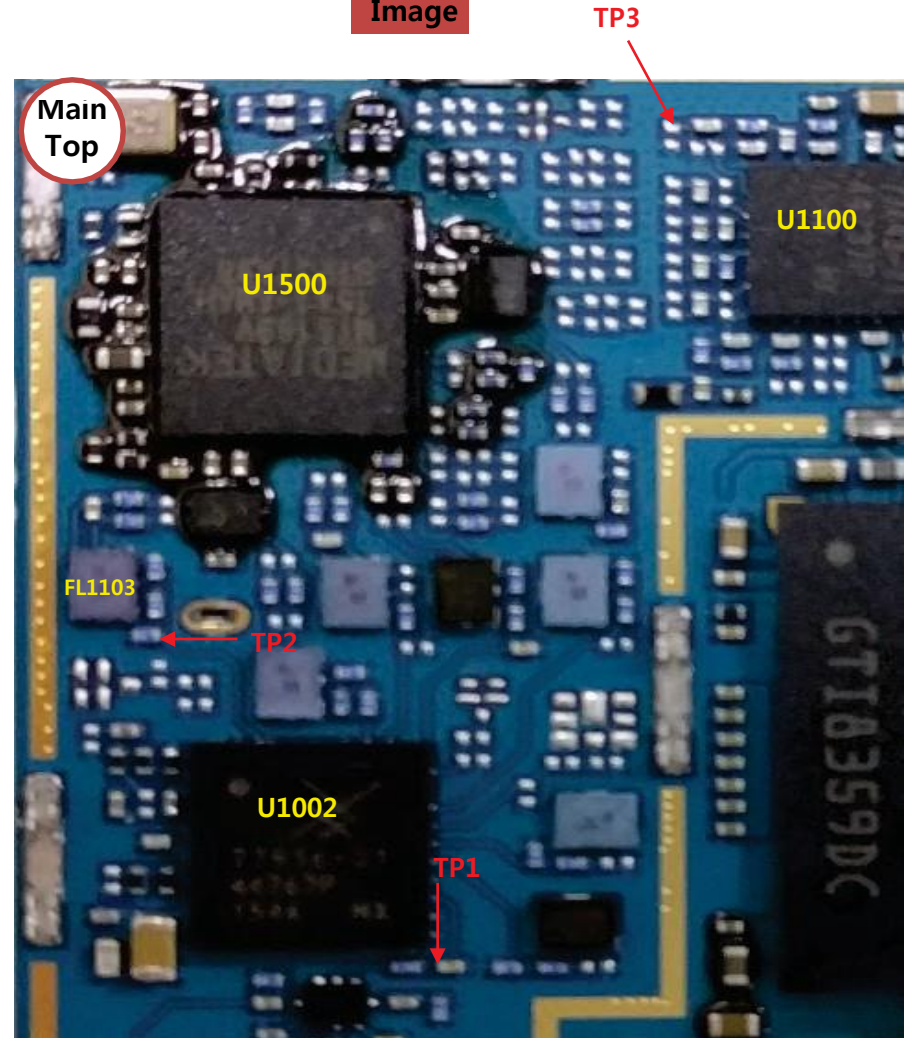

3.7 LTE RF PART

3.7.14 Checking RF Signal TX path(LTE B28B)

Checking Flow

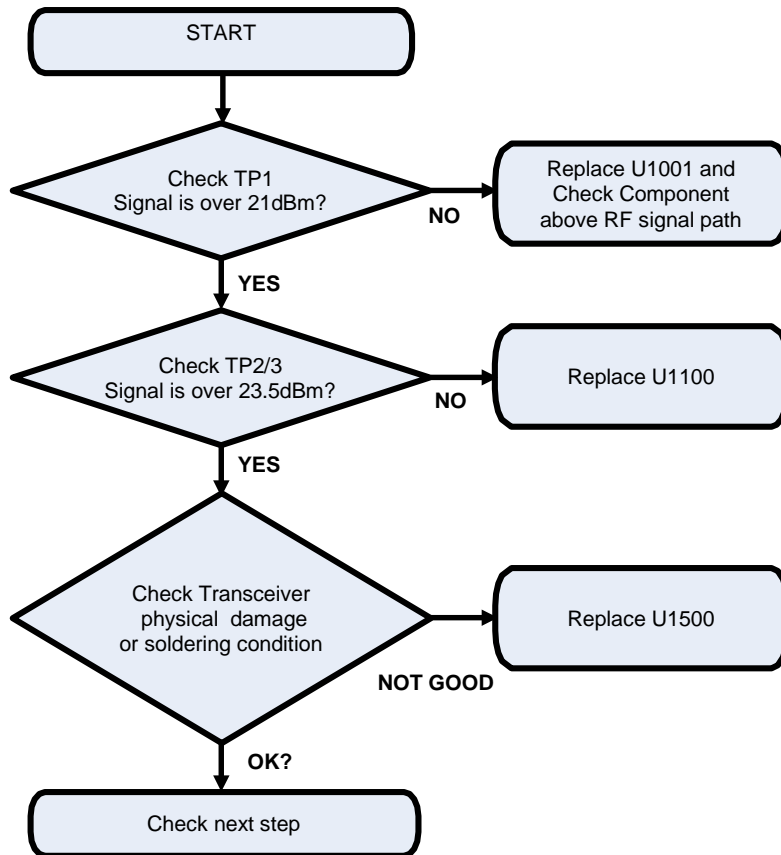

Image

Main Top

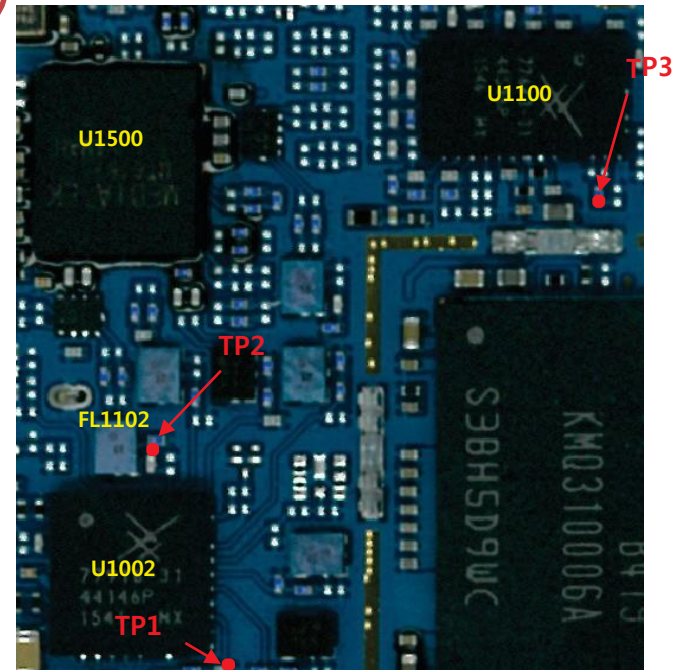

3.7 LTE RF PART

3.7.14 Checking RF Signal TX path(LTE B28A/B)

Circuit Diagram

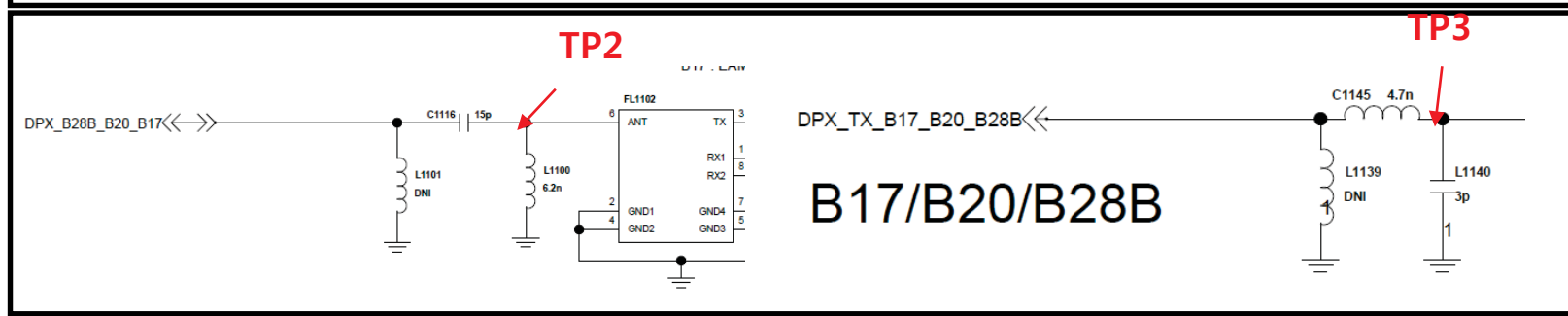
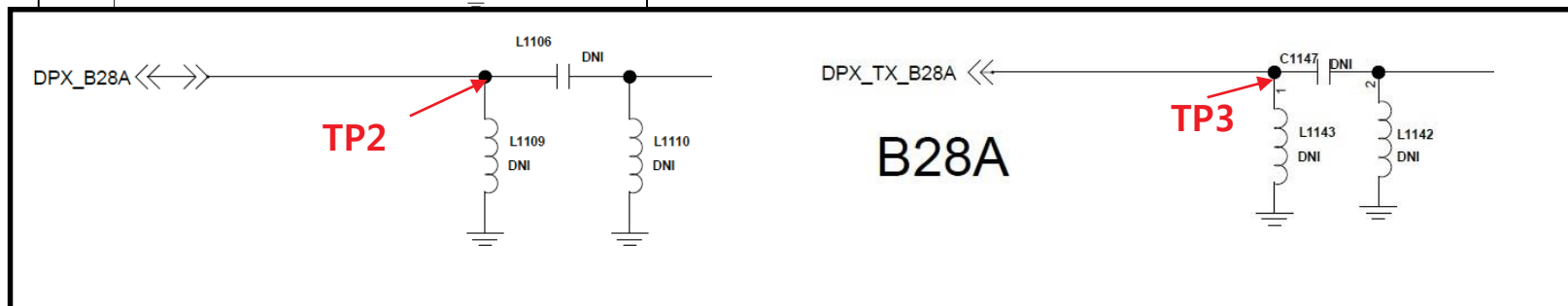
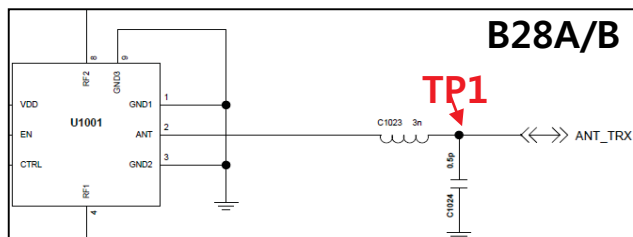

3.8 Power

Checking Power signal (Battery connector, Power Key, PMIC Regulator)

Checking Flow

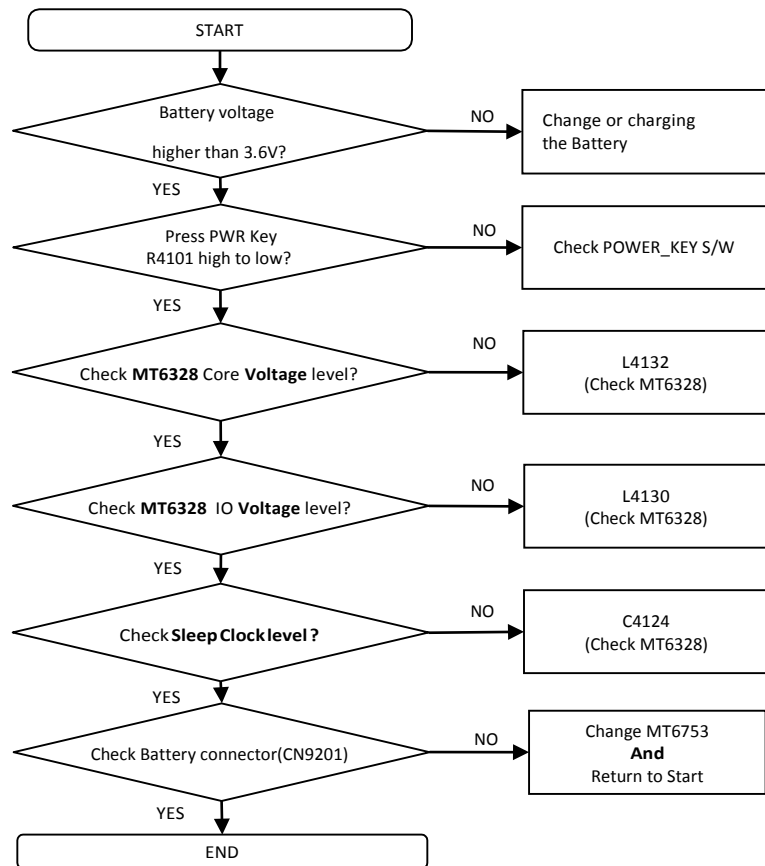

Image

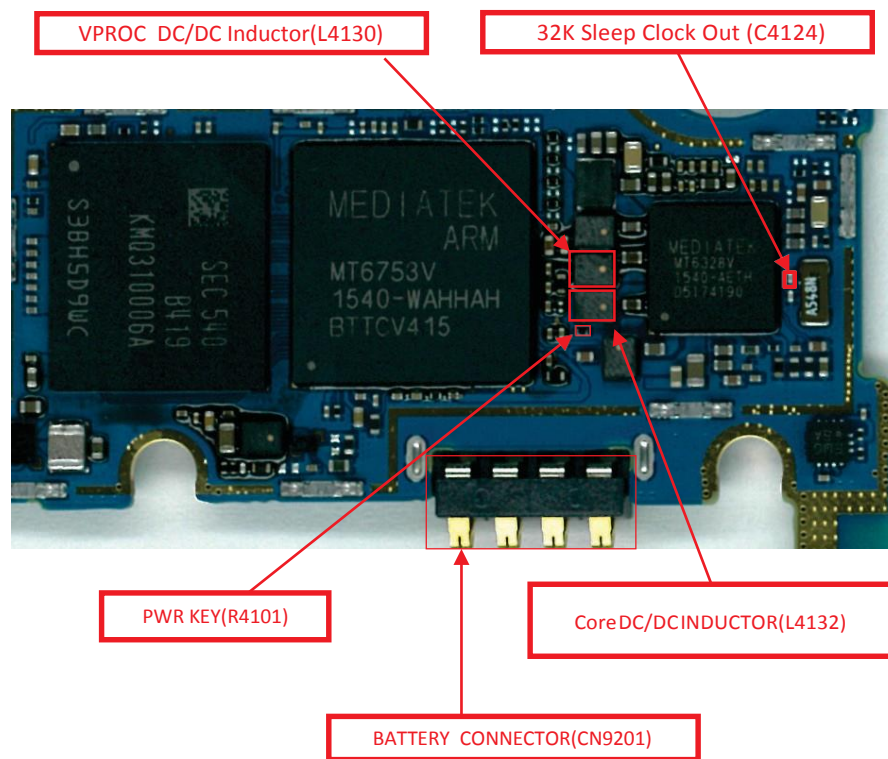

3.8 Power

Checking Power signal (Battery connector, Power Key, PMIC Regulator)

Circuit Diagram

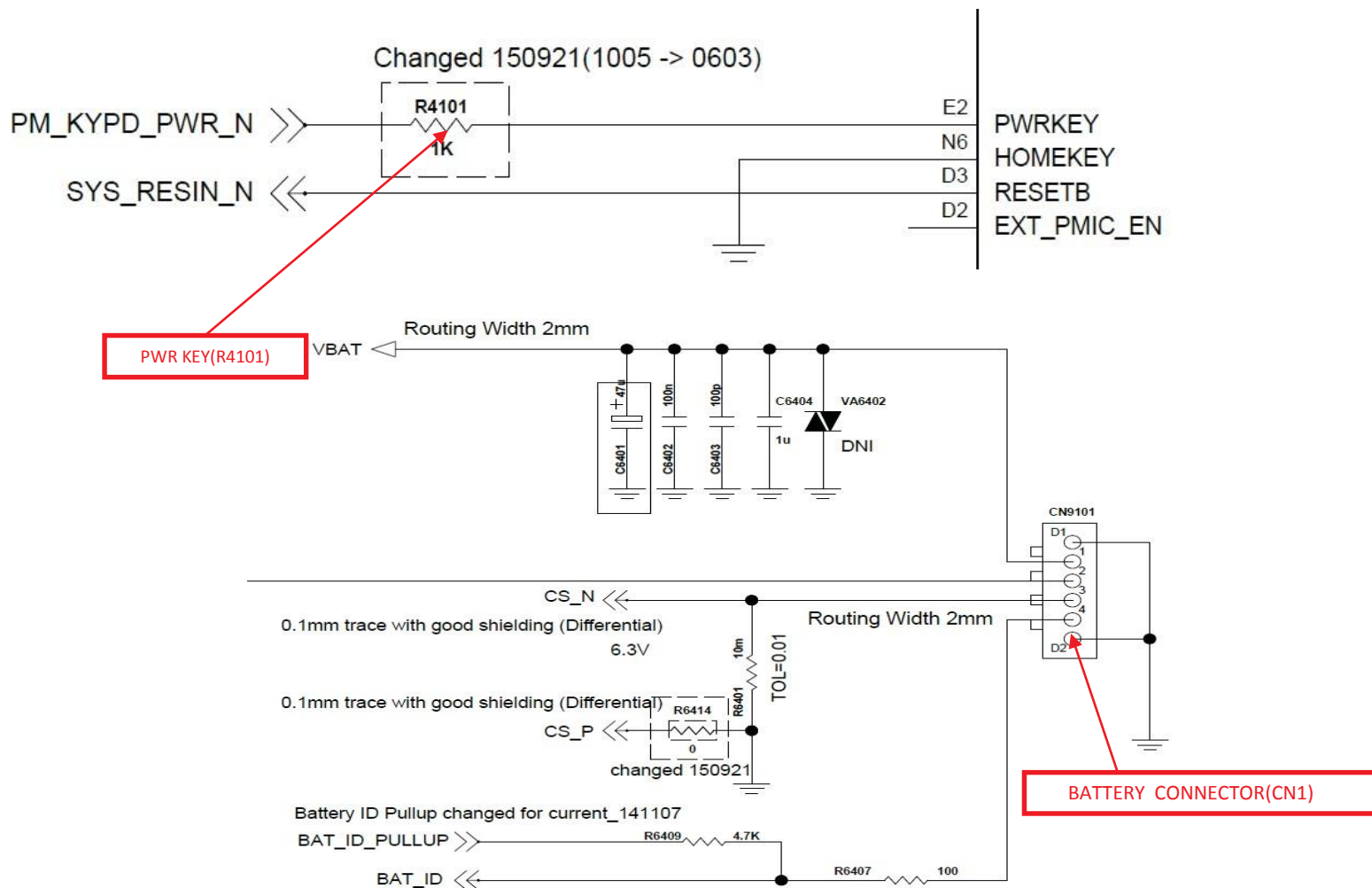

3.8 Power

Checking Power signal (Battery connector, Power Key, PMIC Regulator)

Circuit Diagram

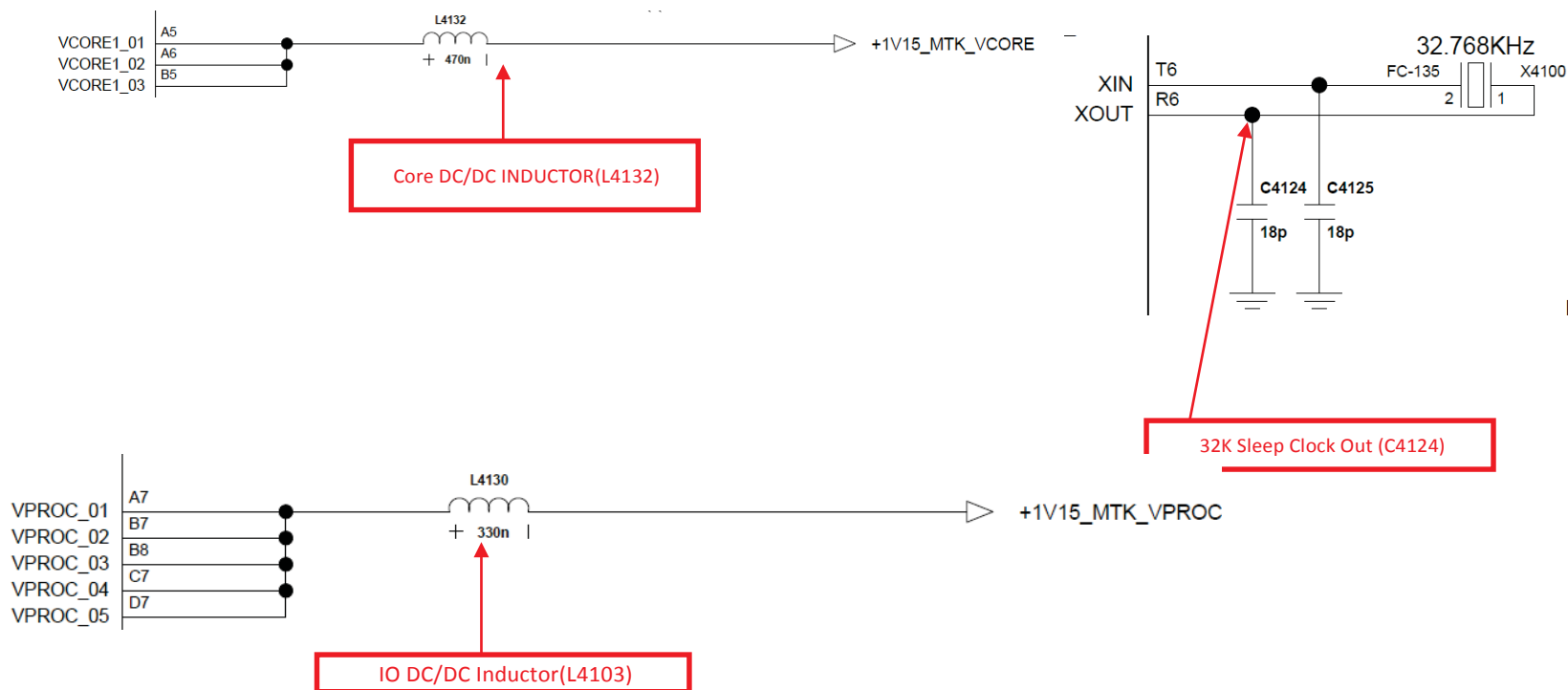

3.9 Charger

The I/O connector and uUSB cable voltage(5.0V) is used as the reference one of PMIC for charging.

Checking Flow

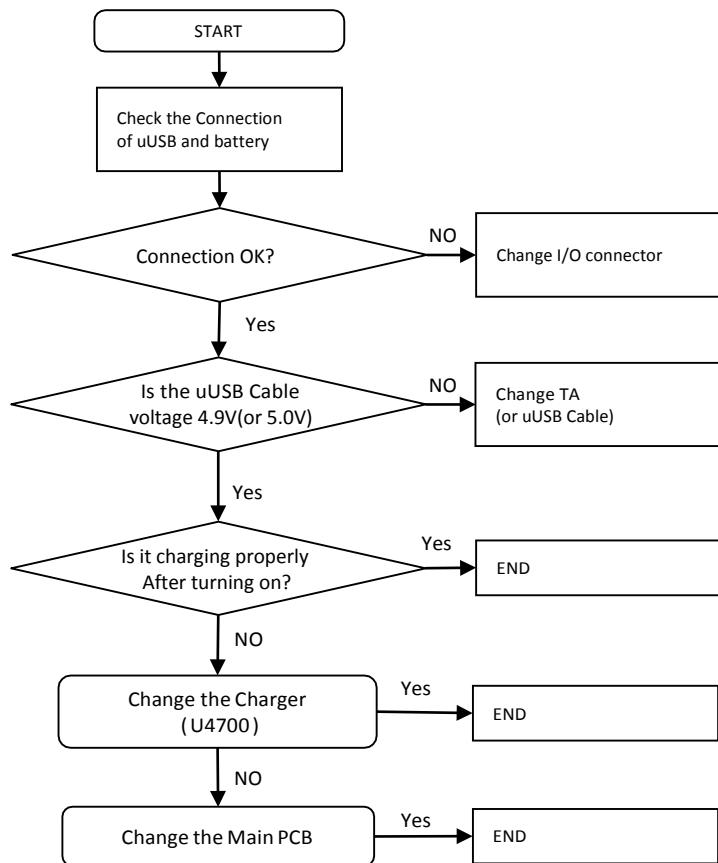

Image

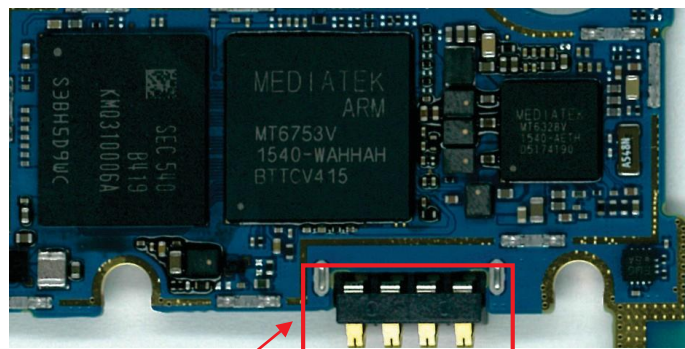

I/O connector

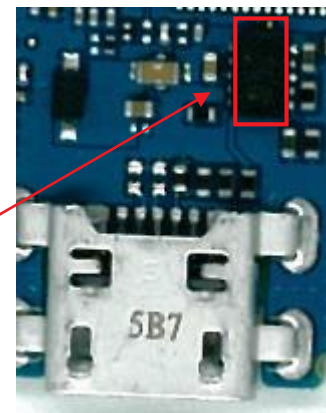

Linear Charger

3. TROUBLE SHOOTING

3.10 Audio Block(3.10.1 Audio receiver)

The receiver control signals are generated by MT6328(U4100), the MT6328 chip and the receiver are to be checked out.

Checking Flow

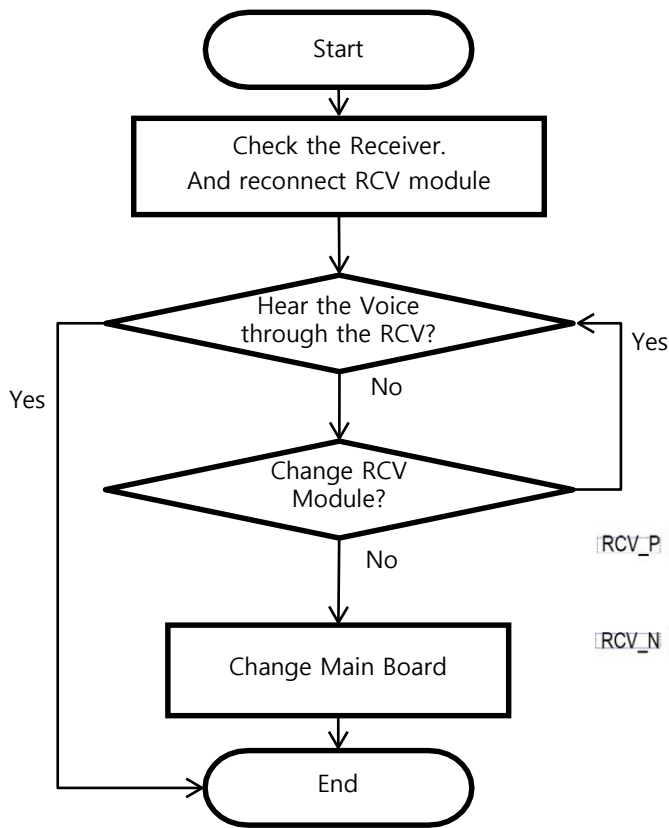

Image



Circuit Diagram

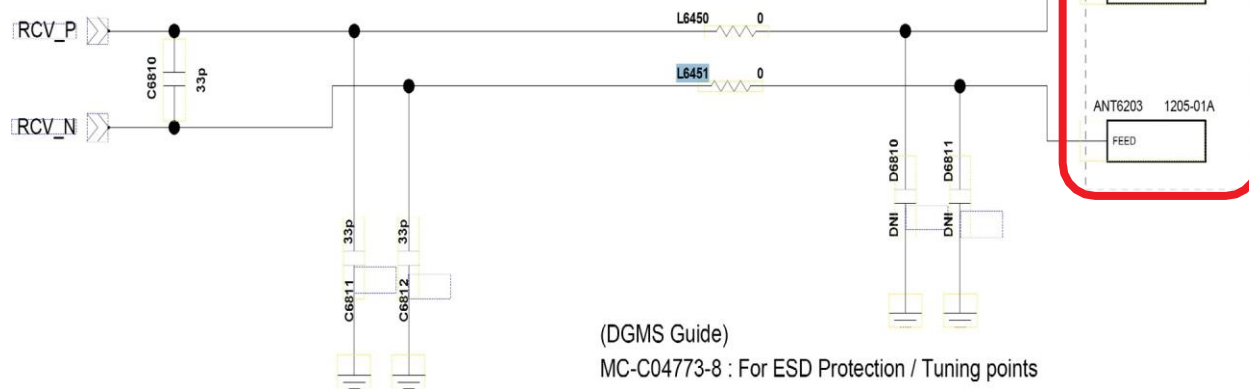

3. TROUBLE SHOOTING

3.10.1 Audio_speaker

The Speaker control signals are generated by MT6328(U4100), the MT6328 chip and the speaker are to be checked out.

Checking Flow

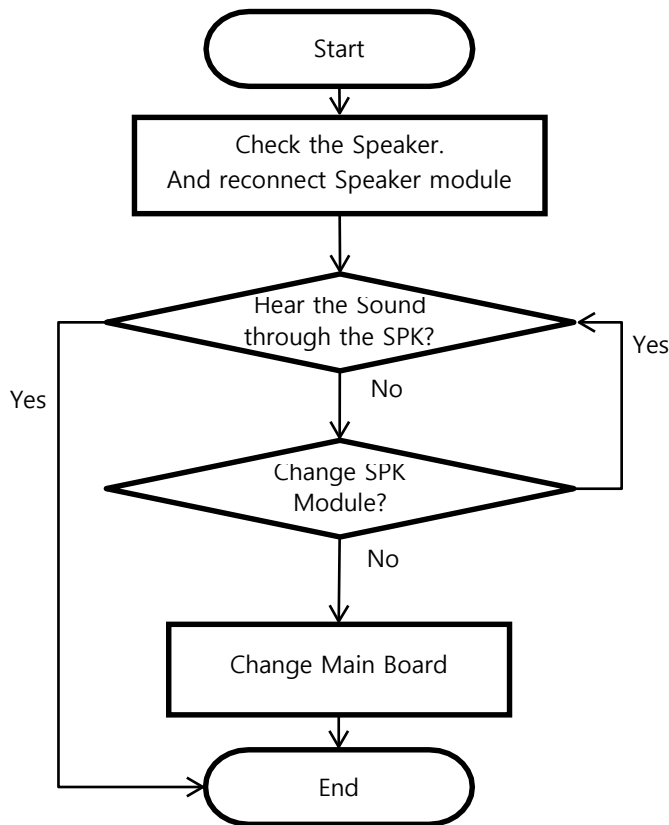

Image

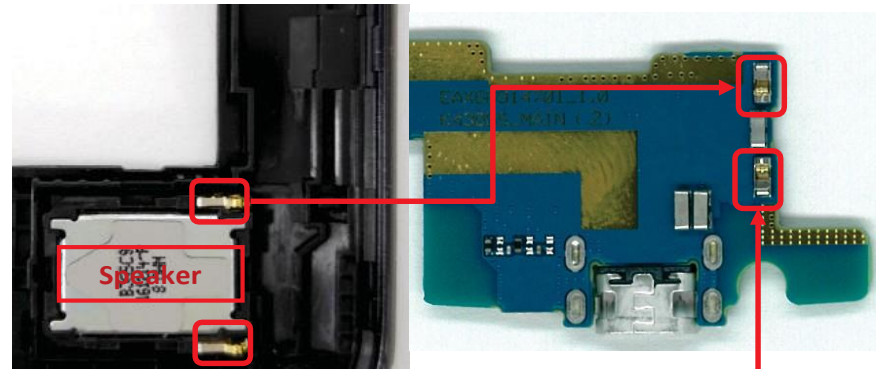

Circuit Diagram

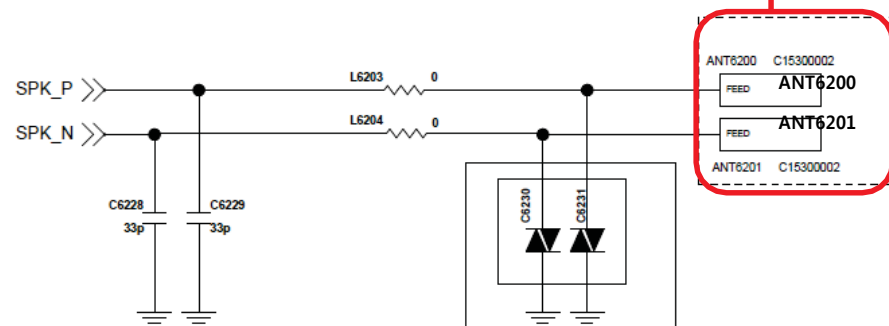

3.10.2 Audio_Main MIC

It's operating voice call(except speakerphone), voice recording, camcorder recording.

Checking Flow

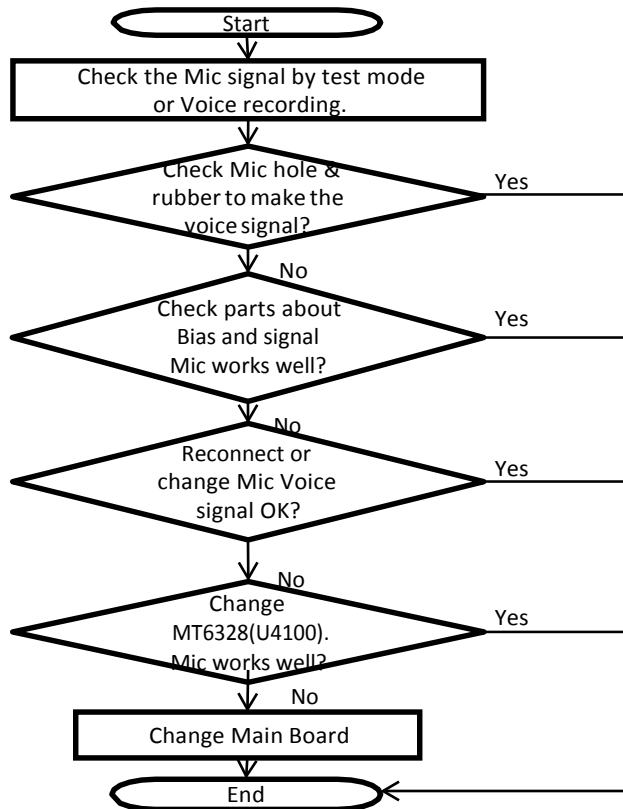

Image

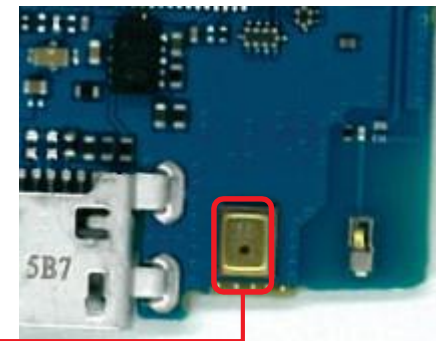
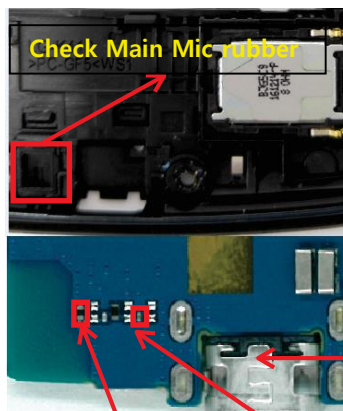

Circuit Diagram

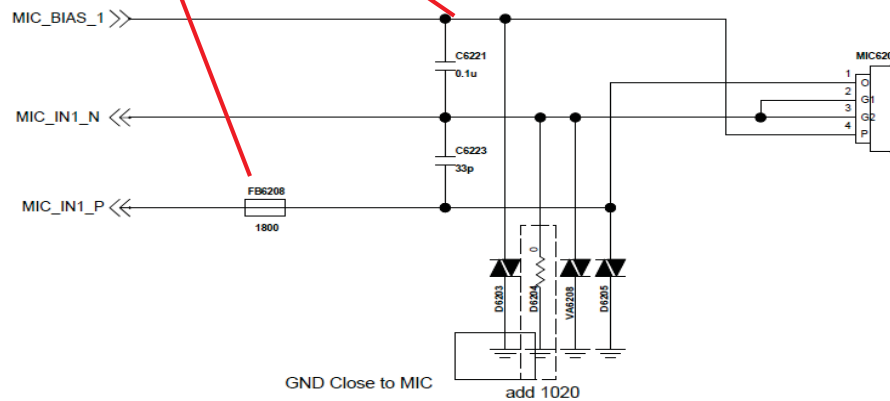

Check FB6208, VMIC voltage level (C6221)

3.10.3 Audio_sub MIC

It's operating Speakerphone call.

Checking Flow

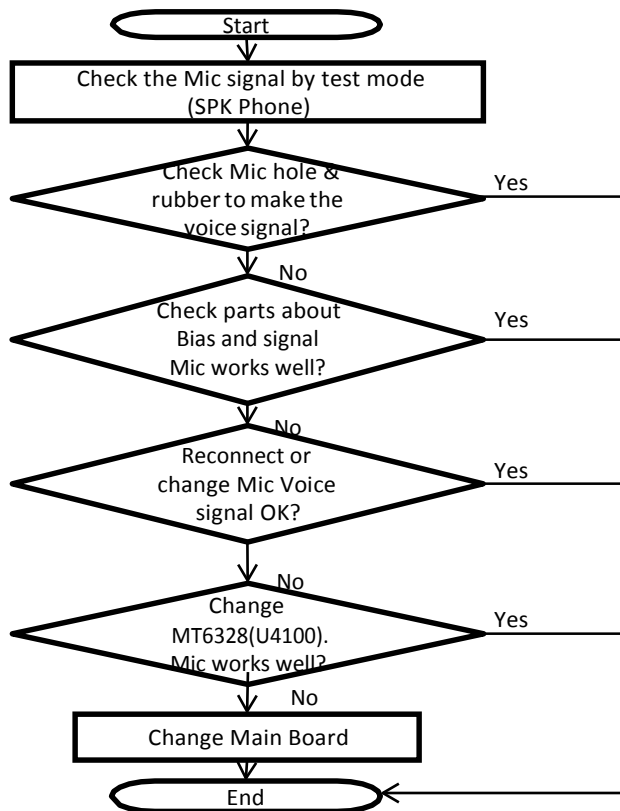

Image

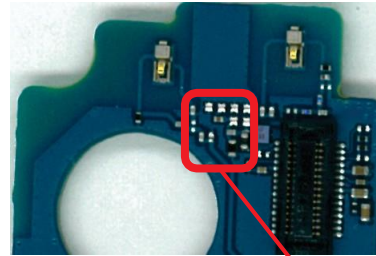

Check SUB Mic rubber

Circuit Diagram

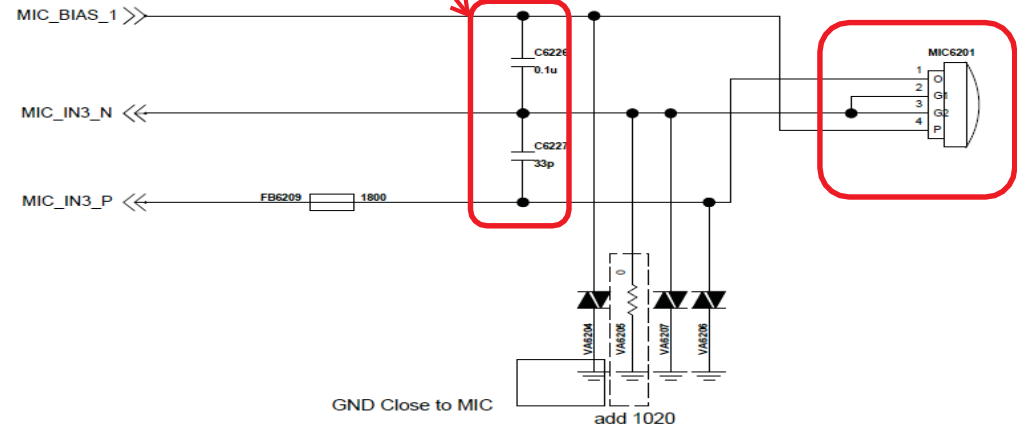

Check FB6209 , VMIC voltage level (C6226)

3. TROUBLE SHOOTING

3.10.4 Audio_Ear MIC Jack

Disable detecting headset insert or No sound from Earphone, Check the Ear Mic and MT6328

Image

Checking Flow

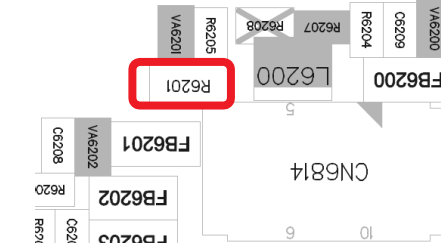
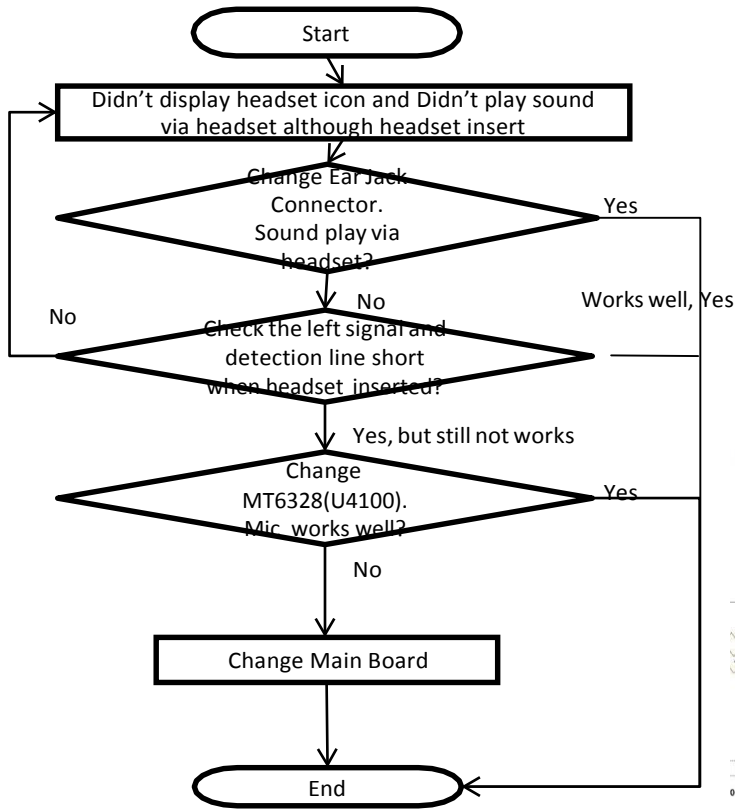

Jack detect
Voltage Level Check at R6201
 - 1.8V(before Jack)
 - low(after Jack)

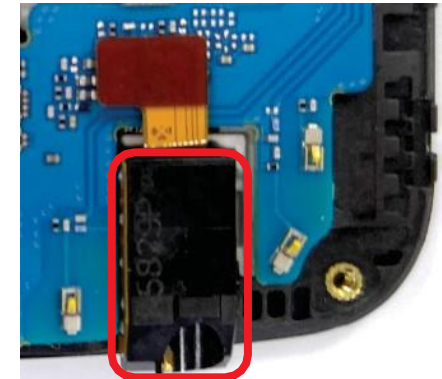

Circuit Diagram

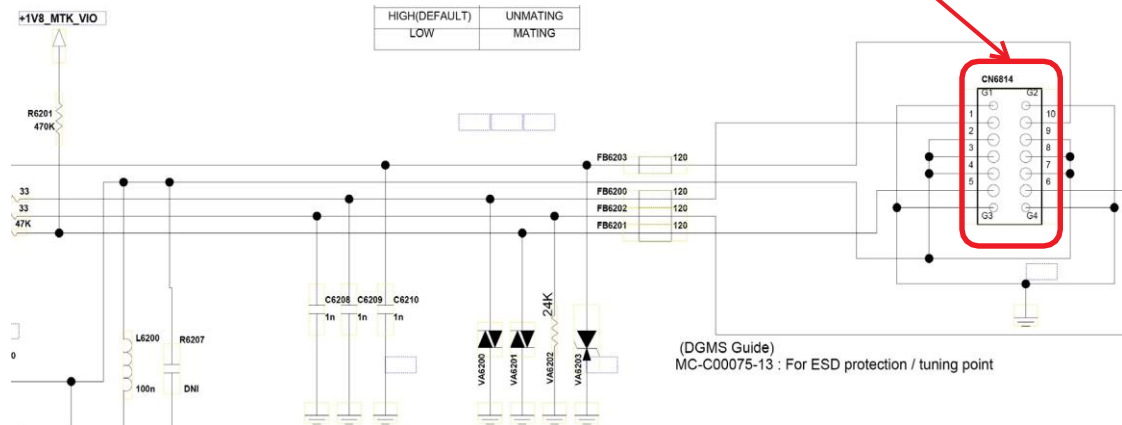

3. TROUBLE SHOOTING

3.10.5 FM_Radio

Disable detecting headset insert or No FM sound from Earphone, Check the Ear Mic and MT6625L

Checking Flow

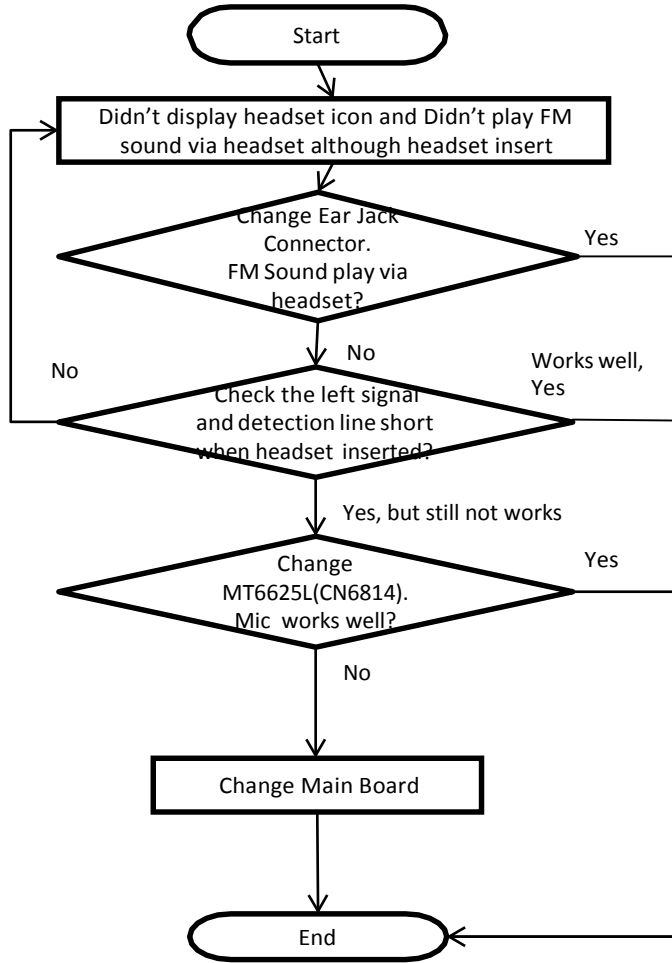

Image

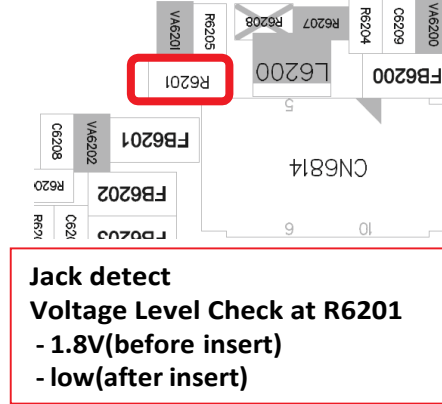

Circuit Diagram

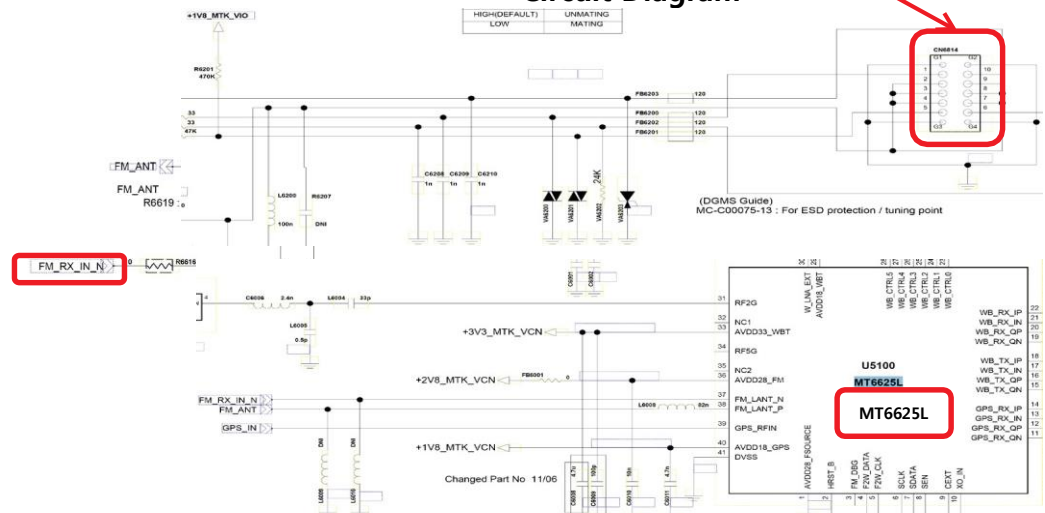

3.11 Checking LCD Block

The LCD control signals are generated by MT6753. Its interface is MIPI having four data lanes and one clock lane.

Checking Flow

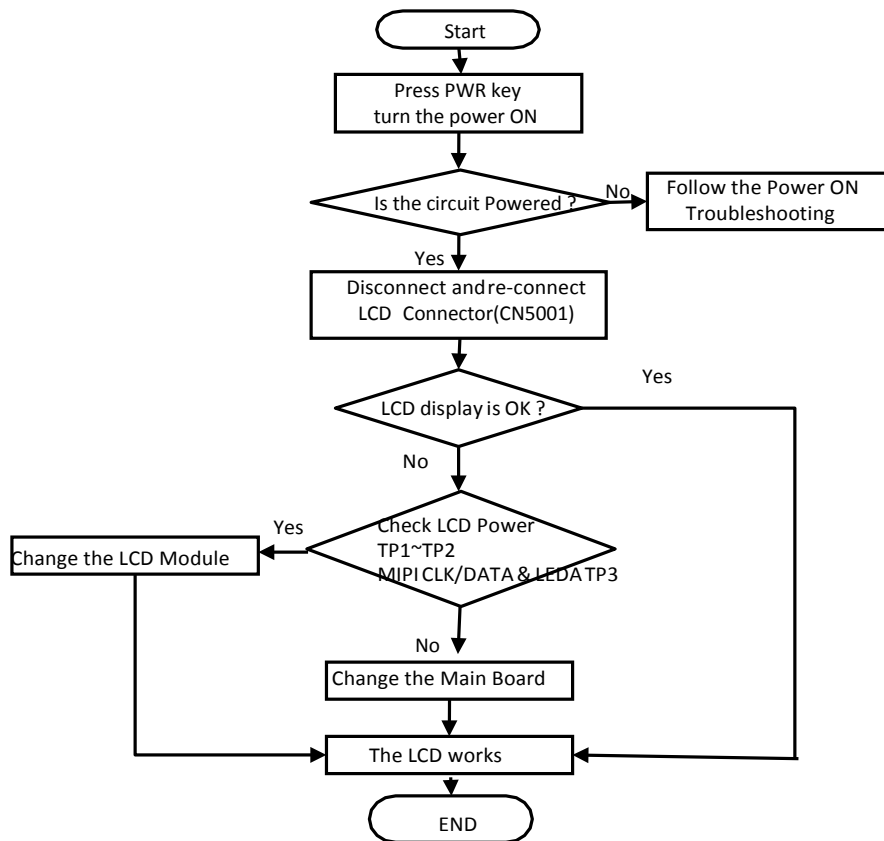

Image

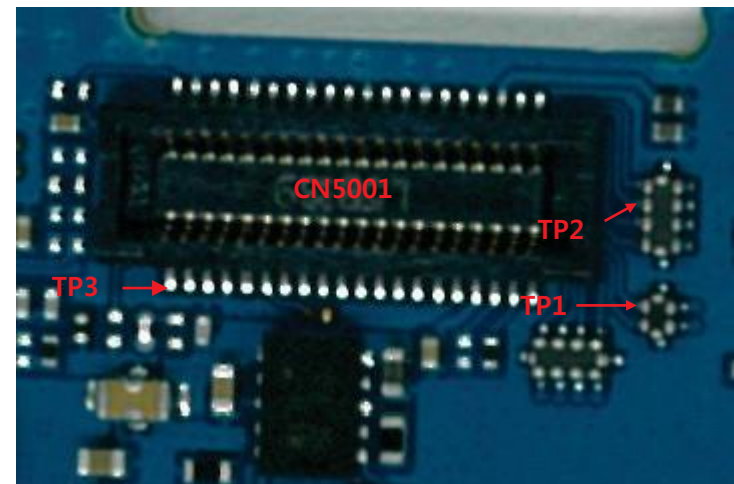

3. TROUBLE SHOOTING

3.11 Checking LCD Block

The LCD control signals are generated by MT6753. Its interface is MIPI having four data lanes and one clock lane.

Circuit Diagram

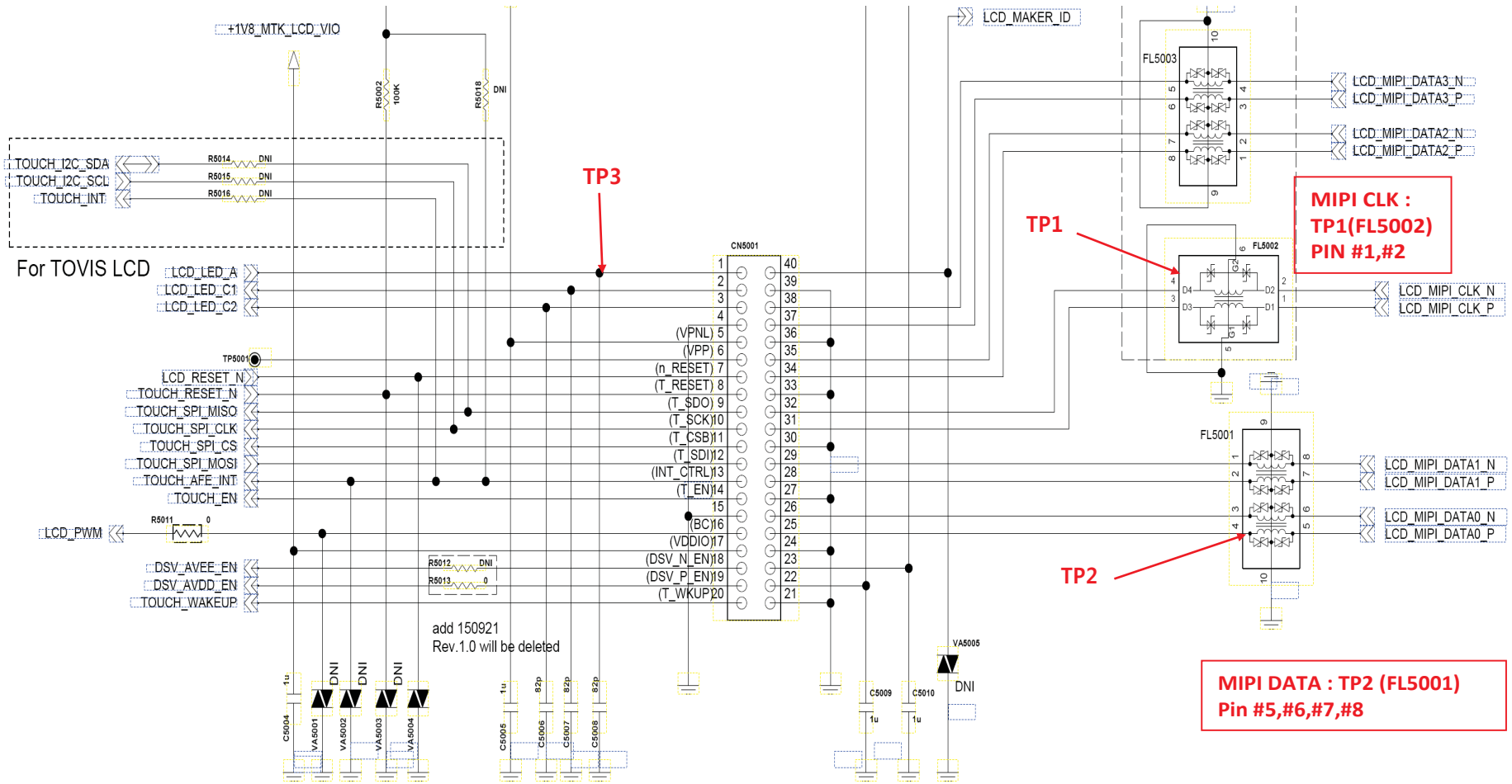

3.12 Checking Touch Block

The Touch control signals are generated by MT6753. It is assembled with LCD.

Checking Flow

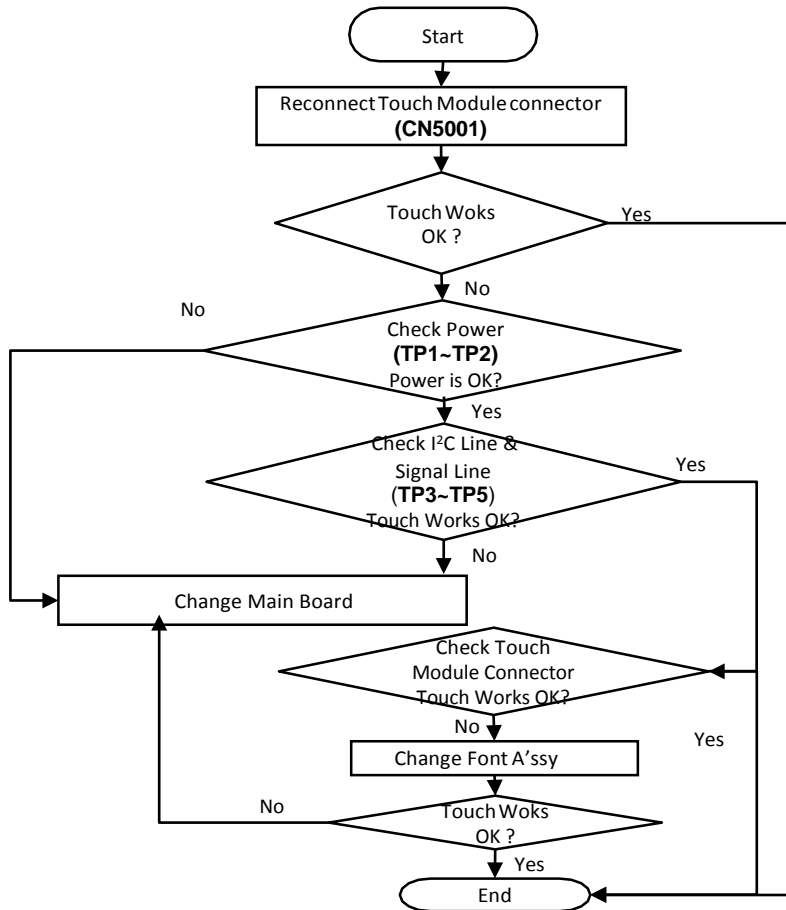

Image

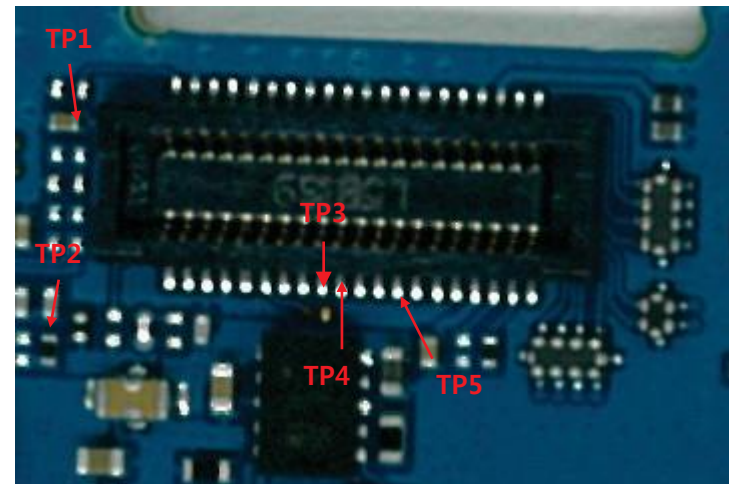

3. TROUBLE SHOOTING

3.12 Checking Touch Block

The Touch control signals are generated by MT6753. It is assembled with LCD.

Circuit Diagram

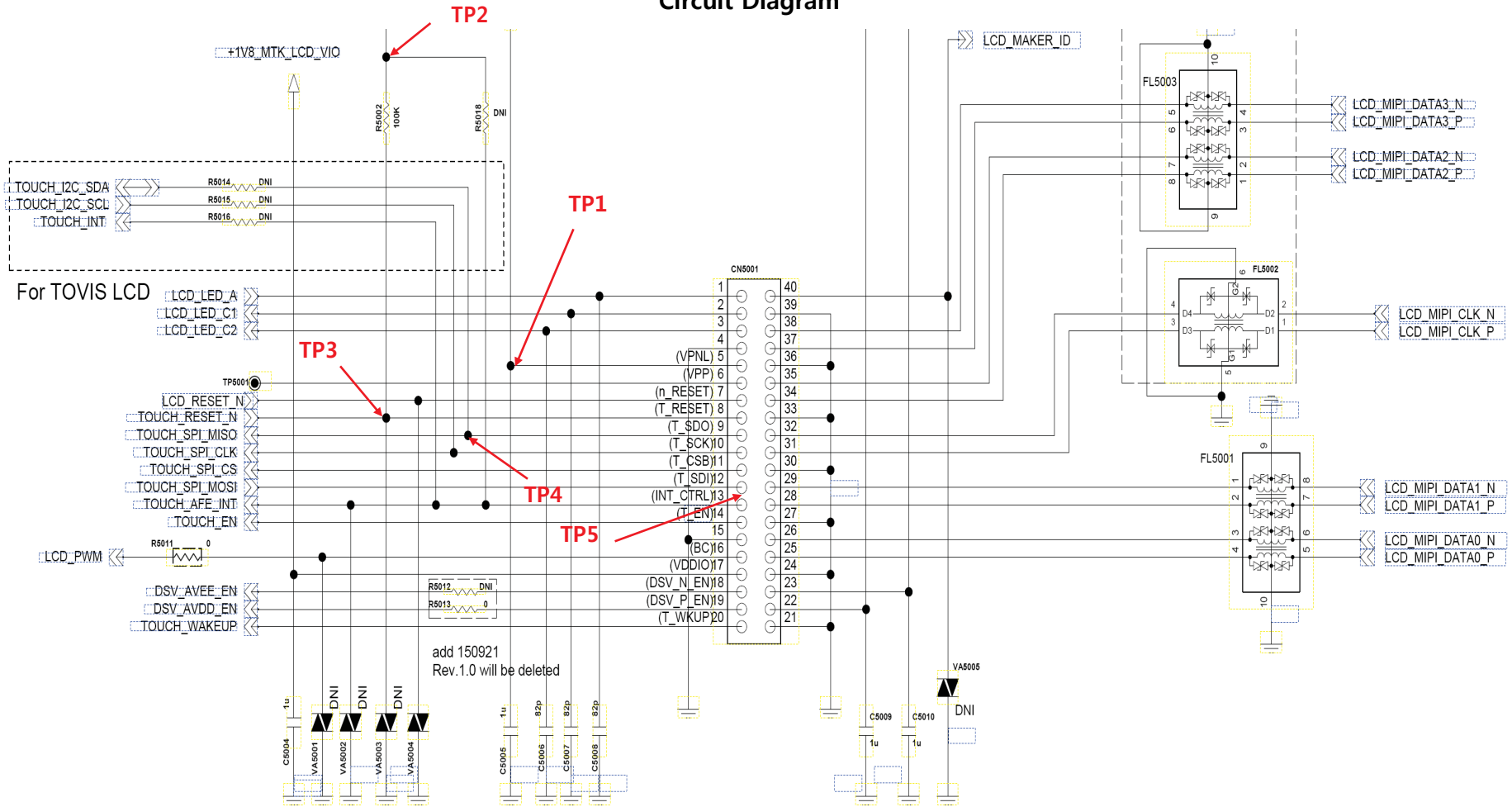

3.13 Checking accelmeter+compass sensor Block

The Accl. & compass sensors are calibrated by using SW algorithm.

Image

Checking Flow

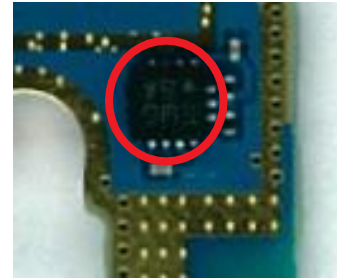
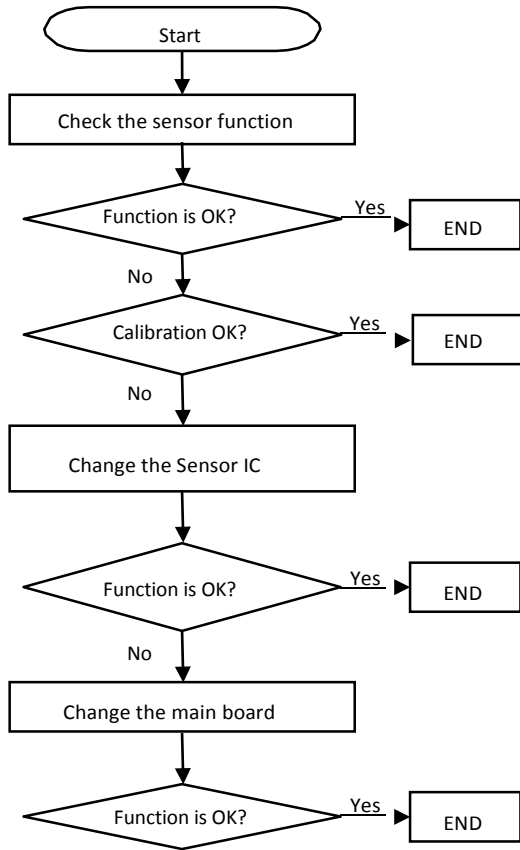

Circuit Diagram

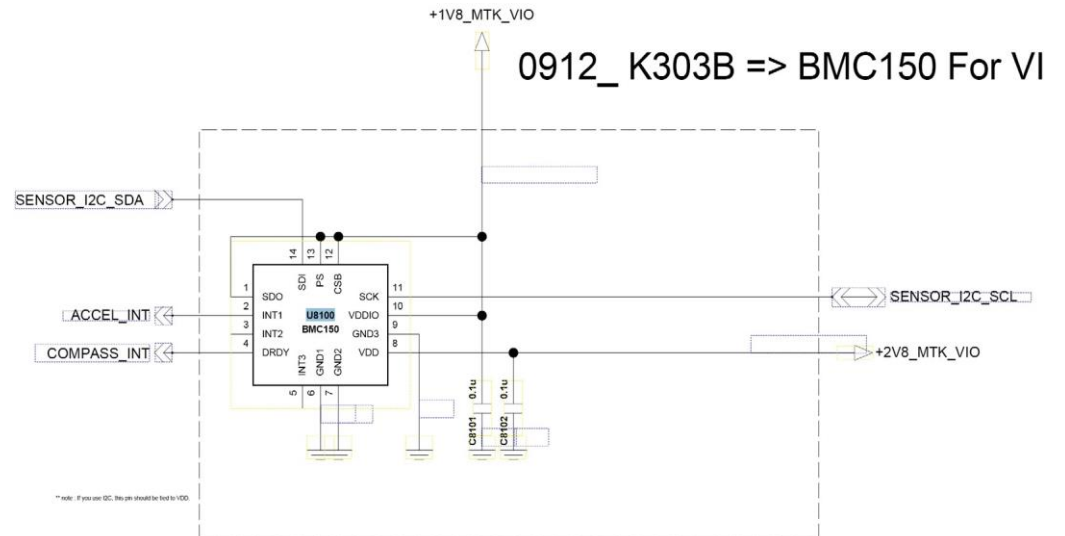

3. TROUBLE SHOOTING

3.13 Checking proximity sensor Block

Proximity Sensor is worked as below: Send Key click → Phone number click → Call connected
→ Object moved at the sensor → Control the screen's on/off operation automatically

Checking Flow

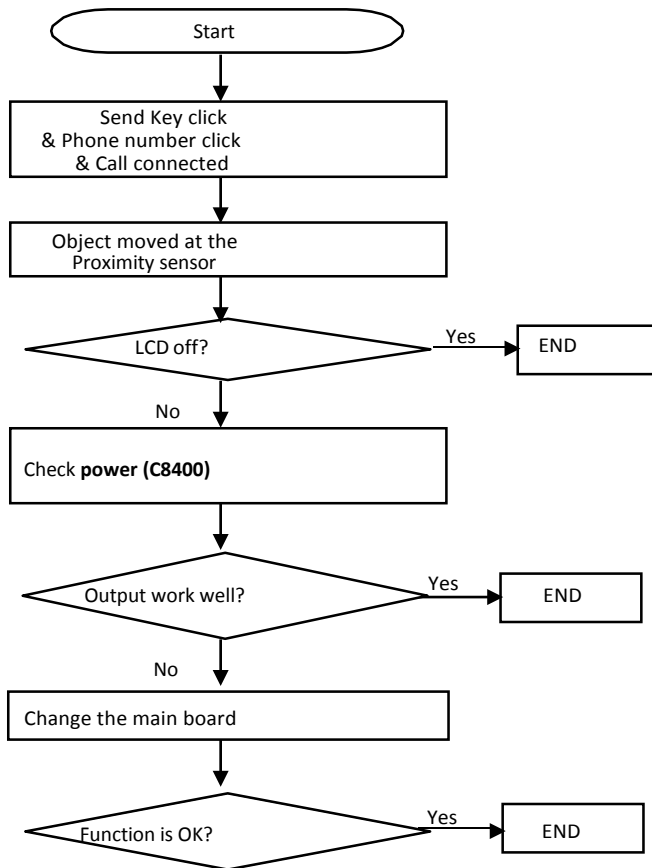

Image

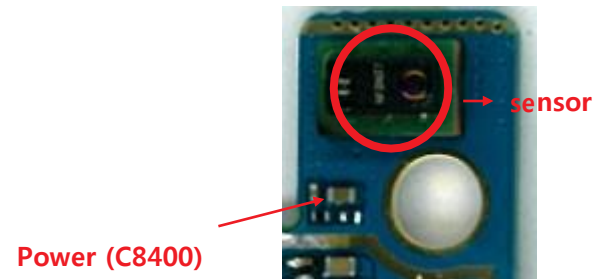

Circuit Diagram

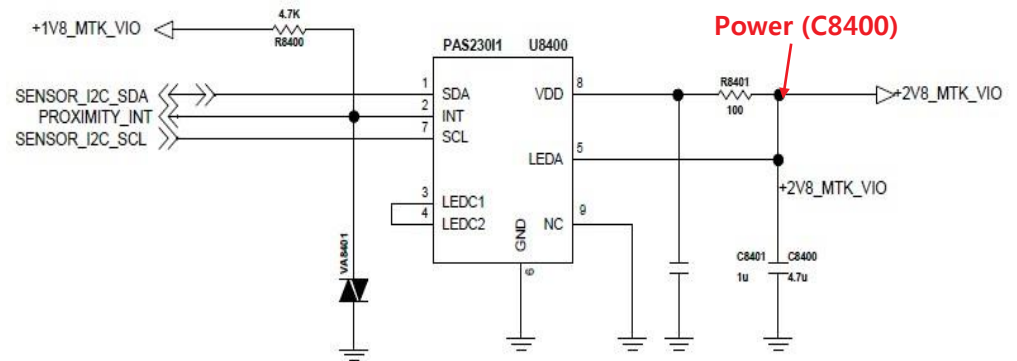

3.14 Checking USB Block

I/O connector is used as the USB port.

Checking Flow

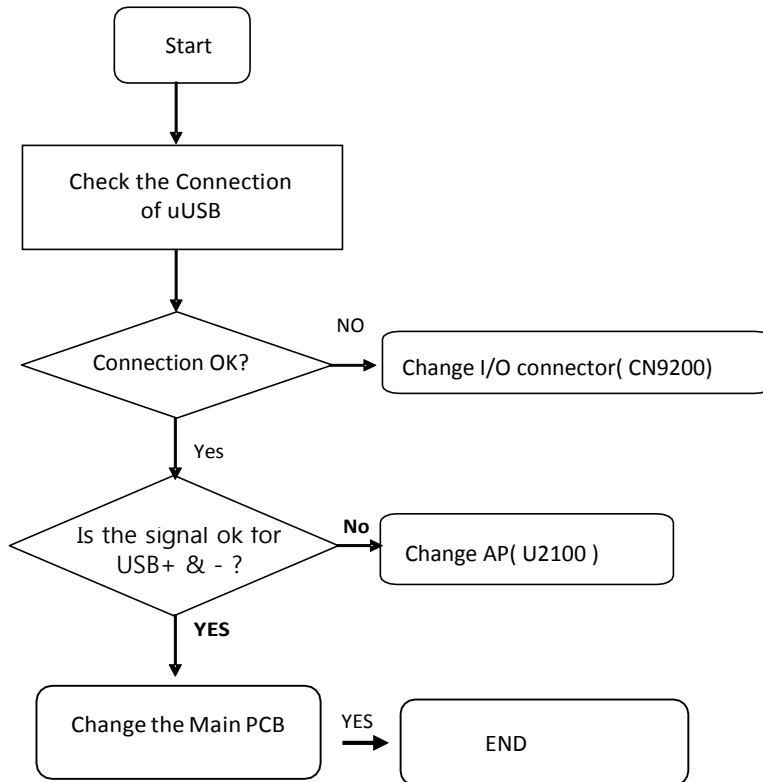

Image



Circuit Diagram

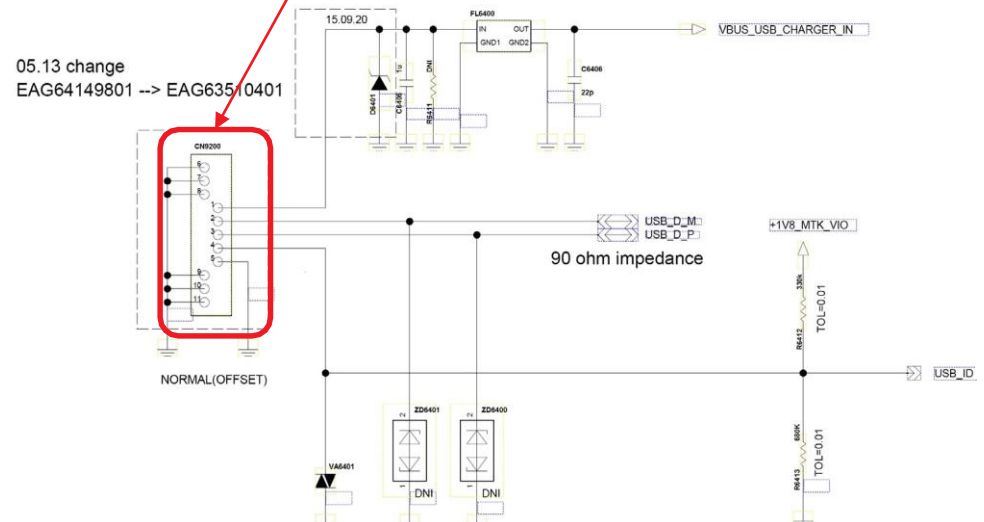

3. TROUBLE SHOOTING

3.15 Checking Main camera Block

8M camera control signals are generated by MT6753 (U2100 : Main Chipset). And powered by MT6328 (U4100 : PMIC).

Checking Flow

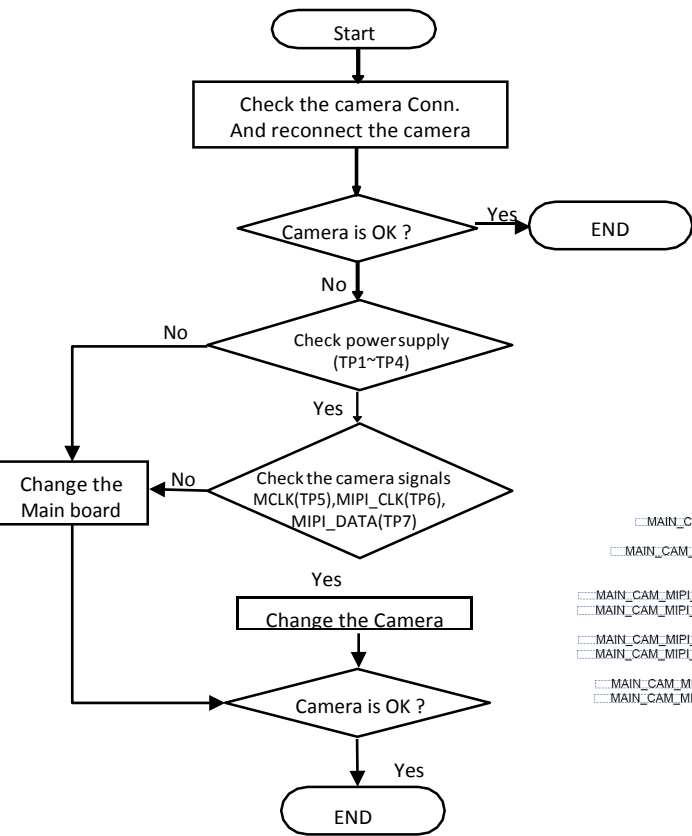

Image

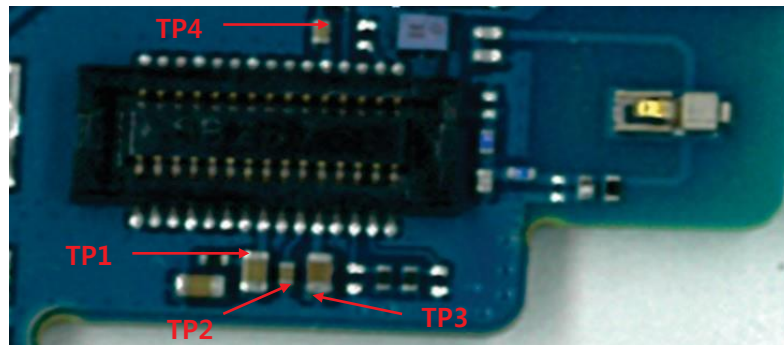

Circuit Diagram

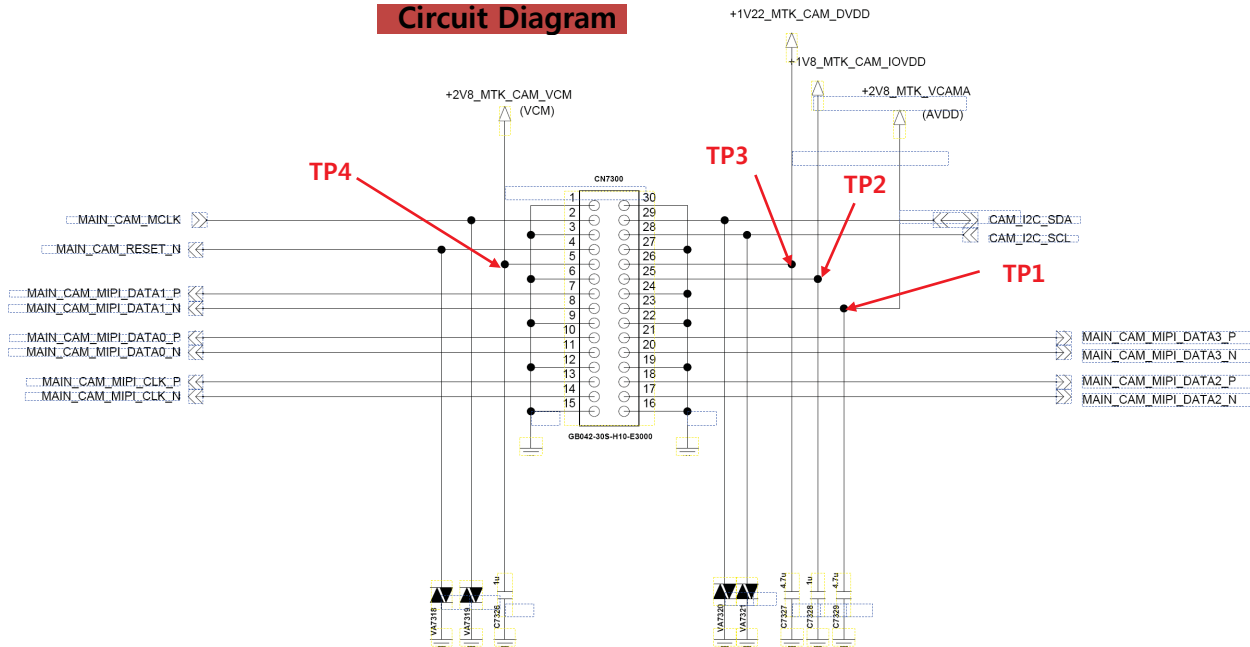

3. TROUBLE SHOOTING

3.15 Checking VT camera Block

5M camera control signals are generated by MT6753 (U2100 : Main Chipset). And powered by MT6328 (U4100 : PMIC).

Checking Flow

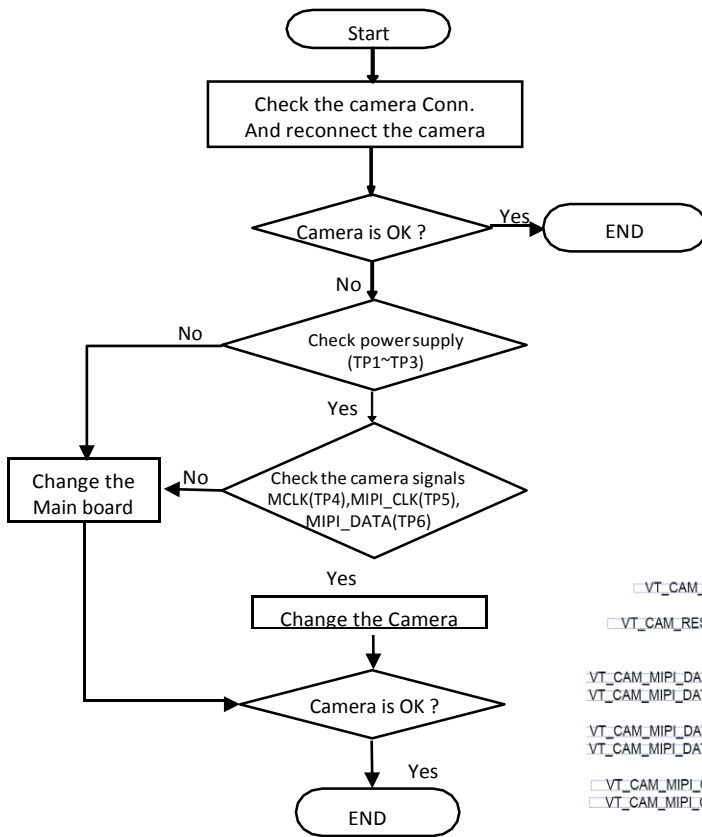

Image

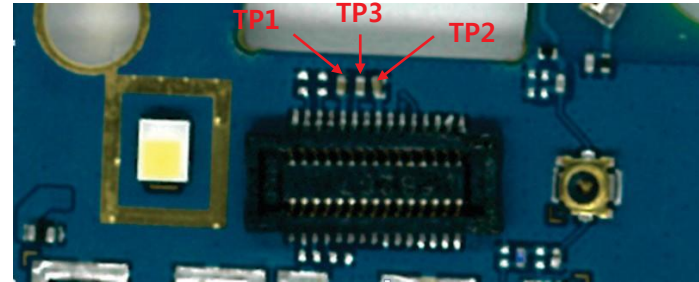

Circuit Diagram

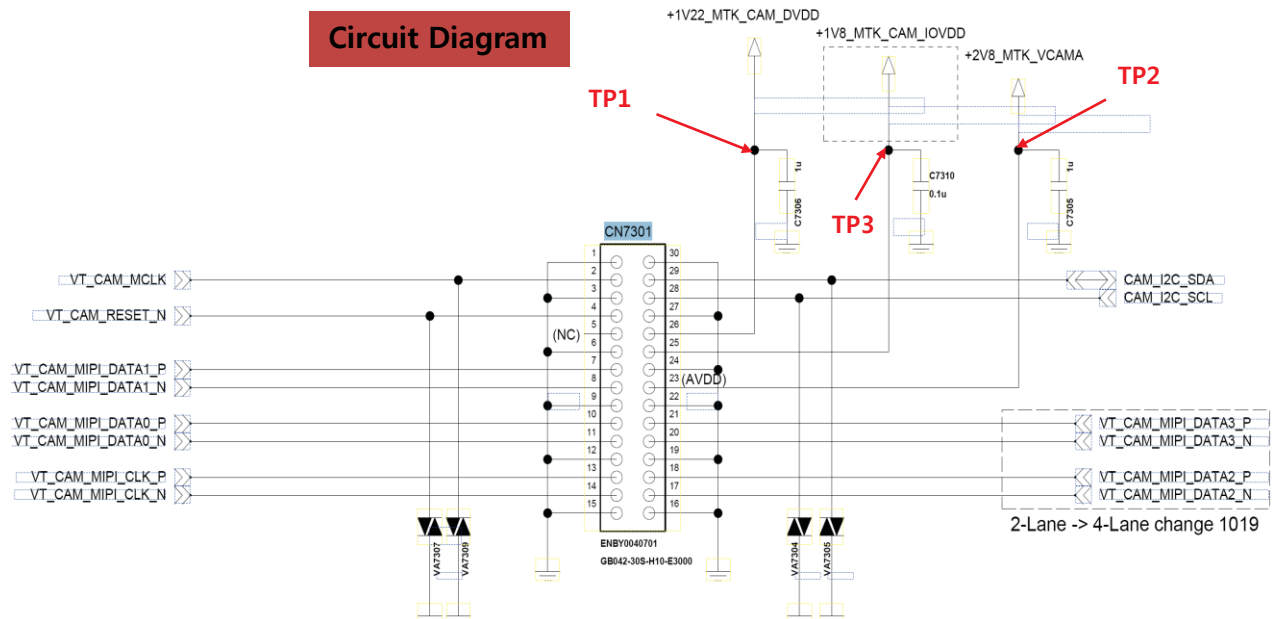

3. TROUBLE SHOOTING

3.16 Connectivity RF PART

3.16.1 Checking RF Signal TRX path(WiFi, BT)

Checking Flow

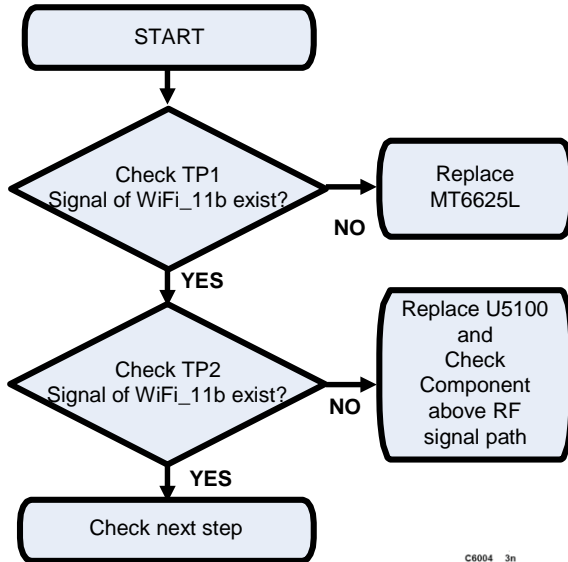

Image

Main BOT
TP2

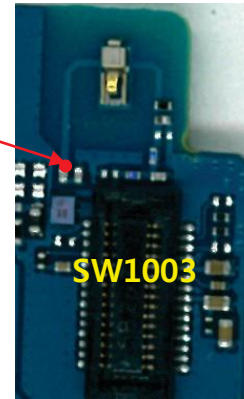

Main TOP
TP1

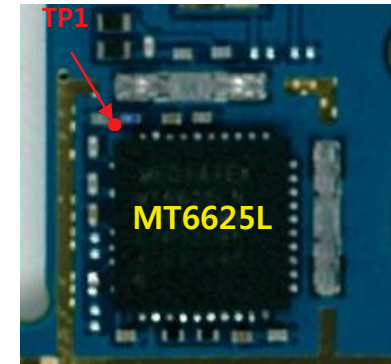

Circuit Diagram

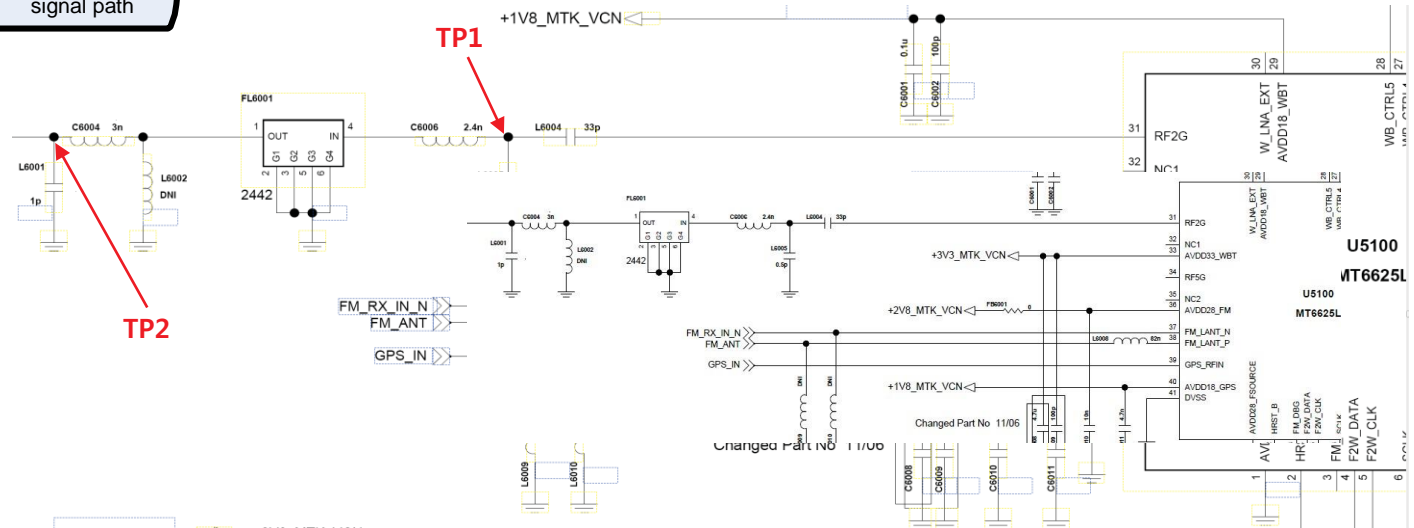

3.16 Connectivity RF PART

3.16.2 Checking RF Signal TRX path(GPS)

Checking Flow

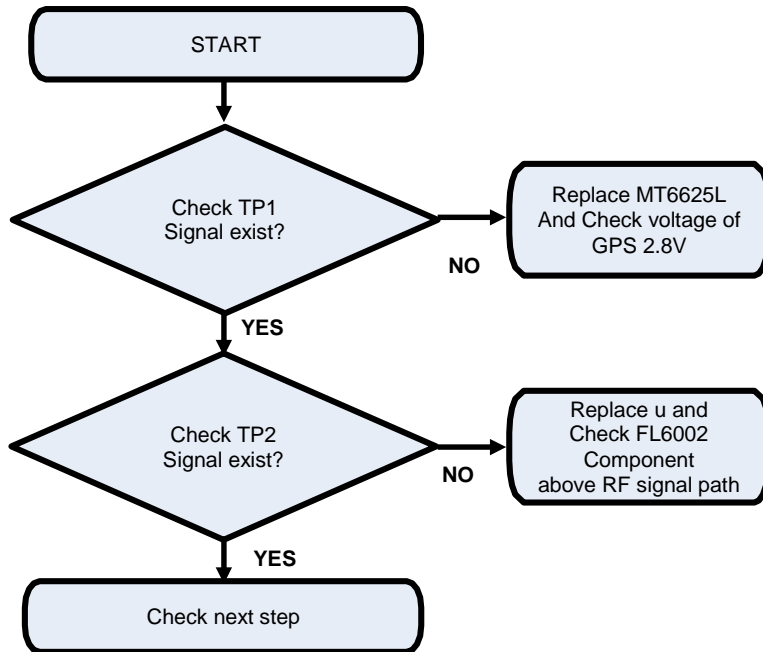

Image

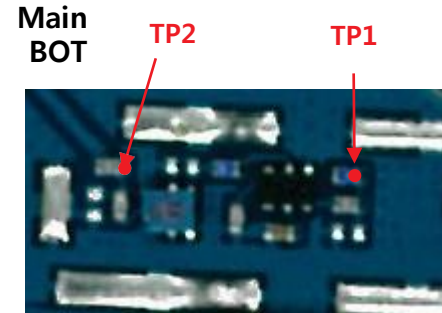

Circuit Diagram

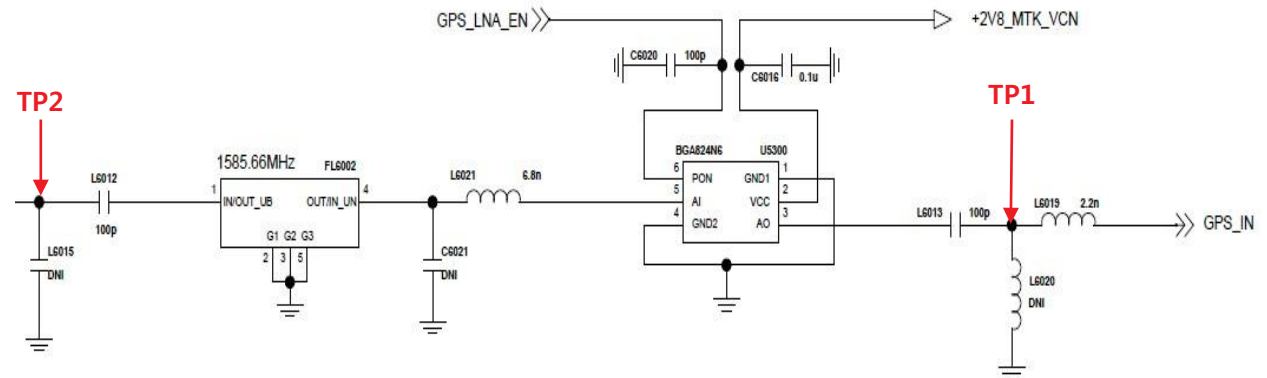

4. BLOCK DIAGRAM

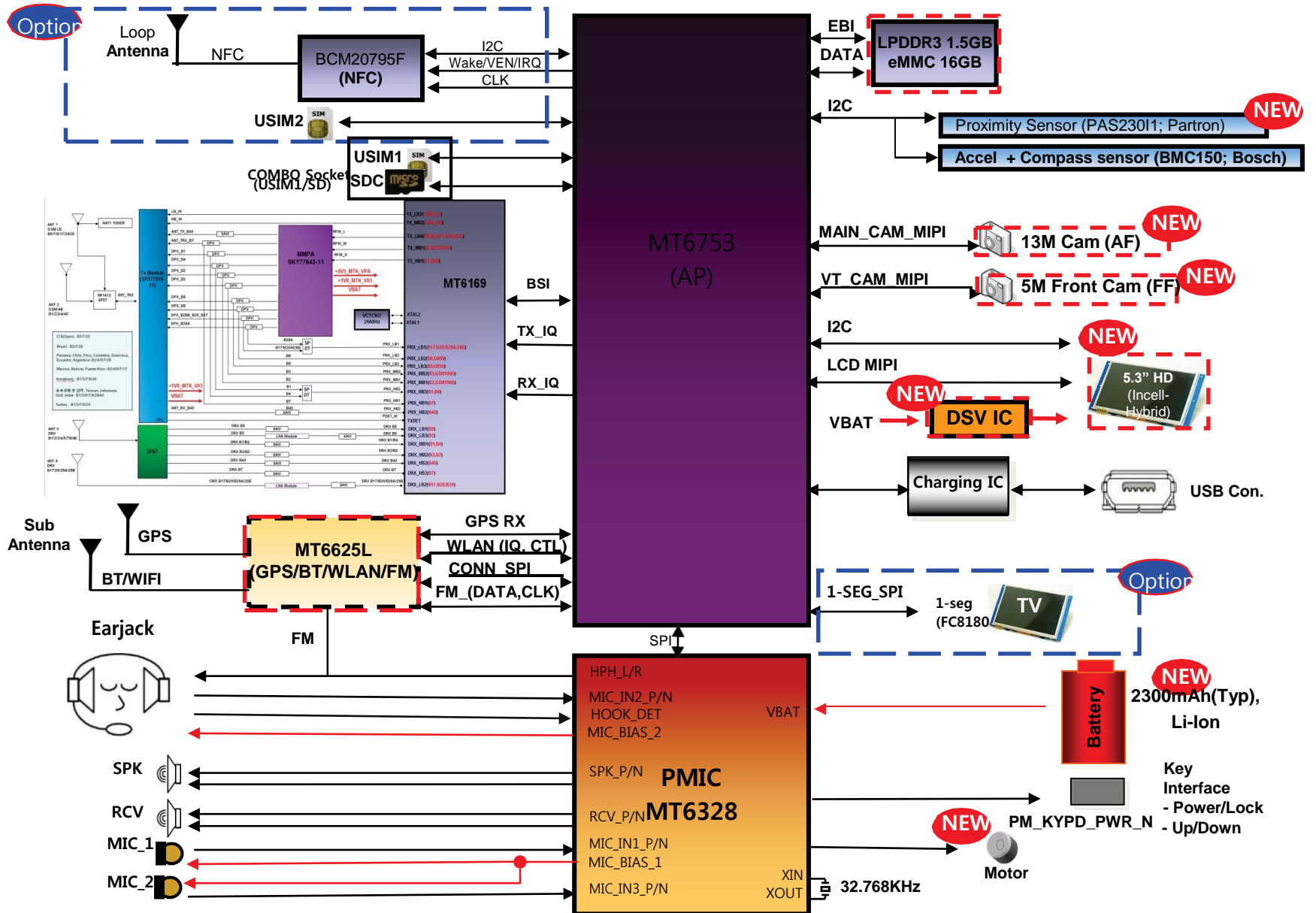

4. BLOCK DIAGRAM

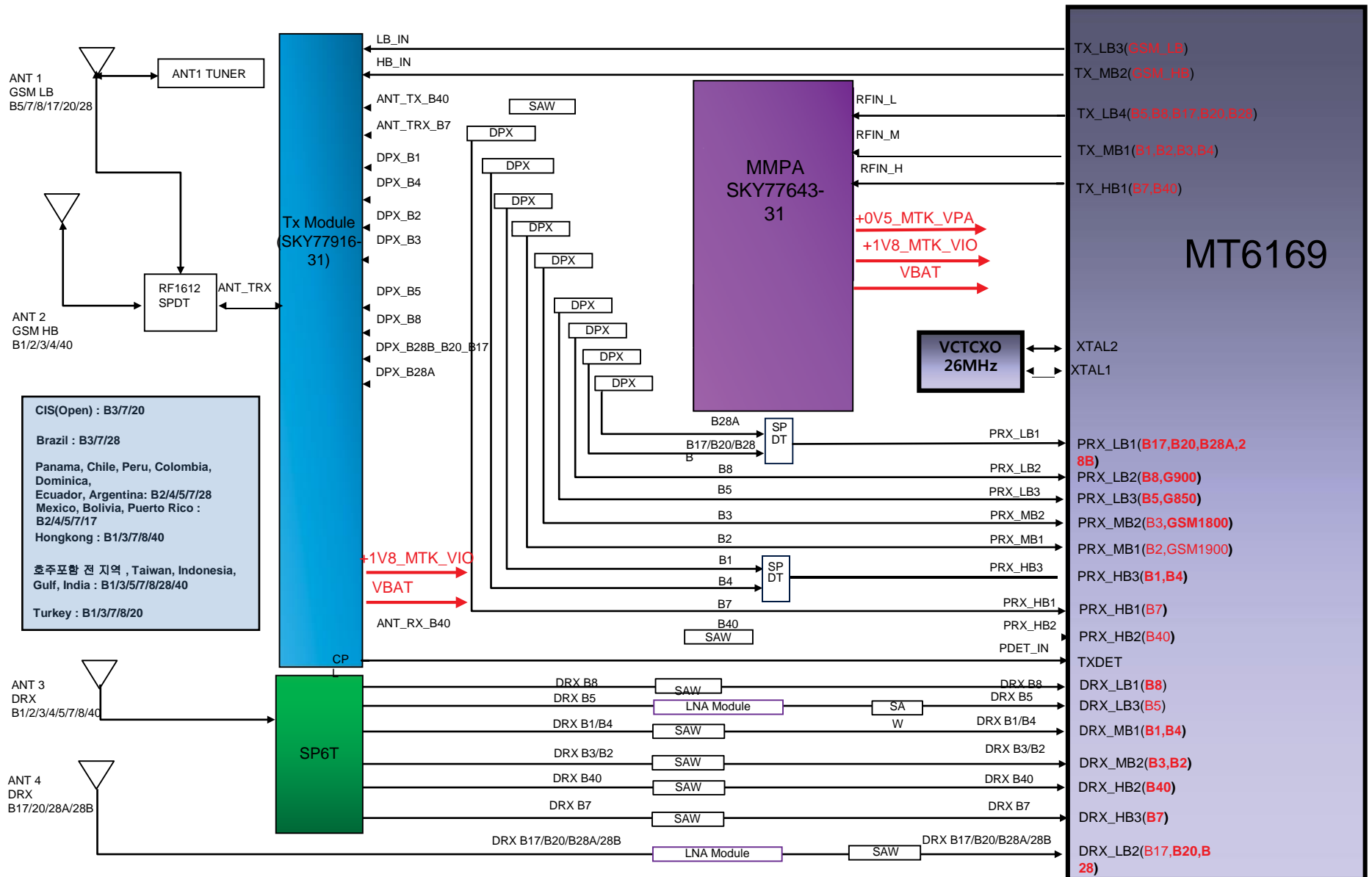

4. BLOCK DIAGRAM

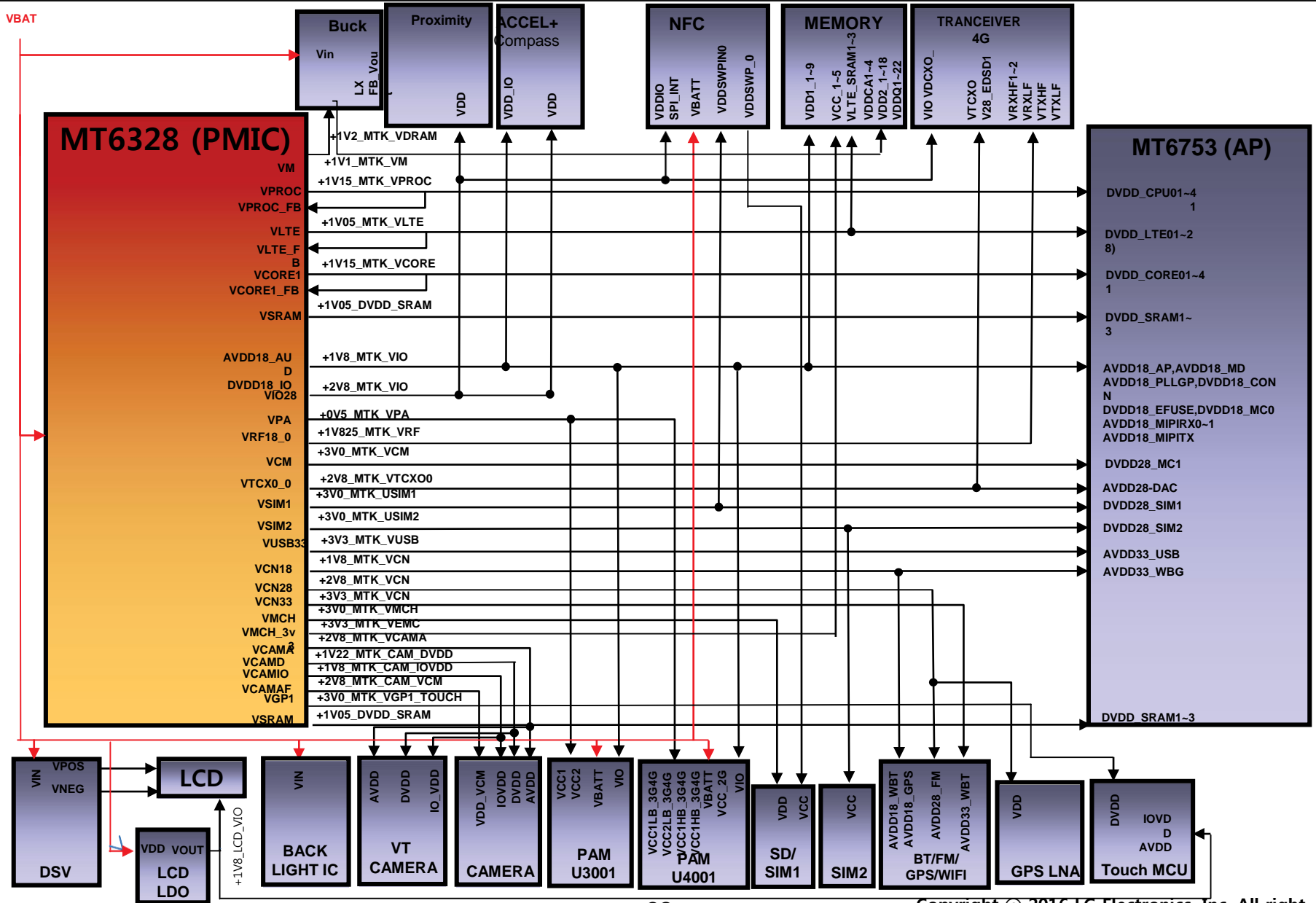

4. BLOCK DIAGRAM

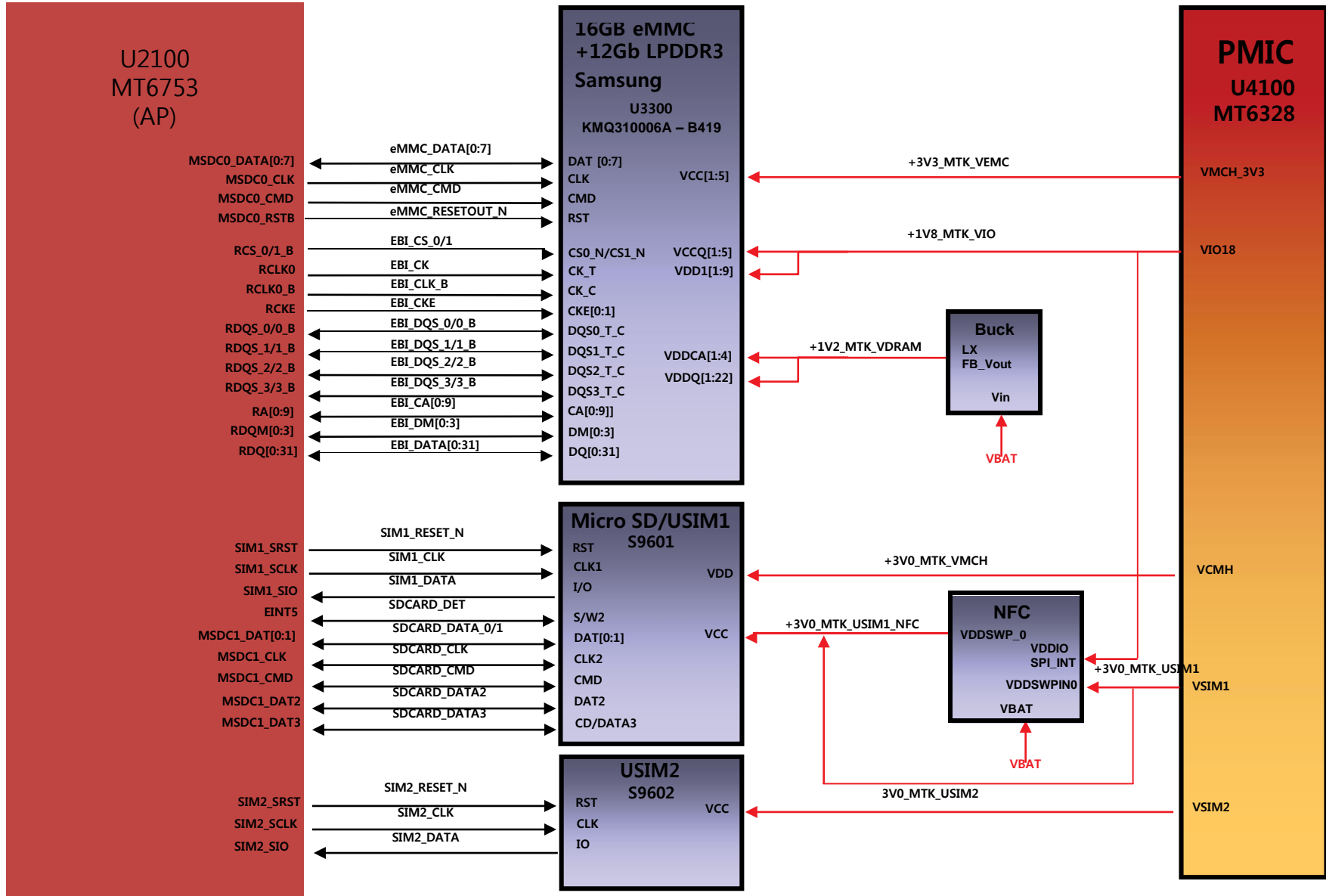

4. BLOCK DIAGRAM

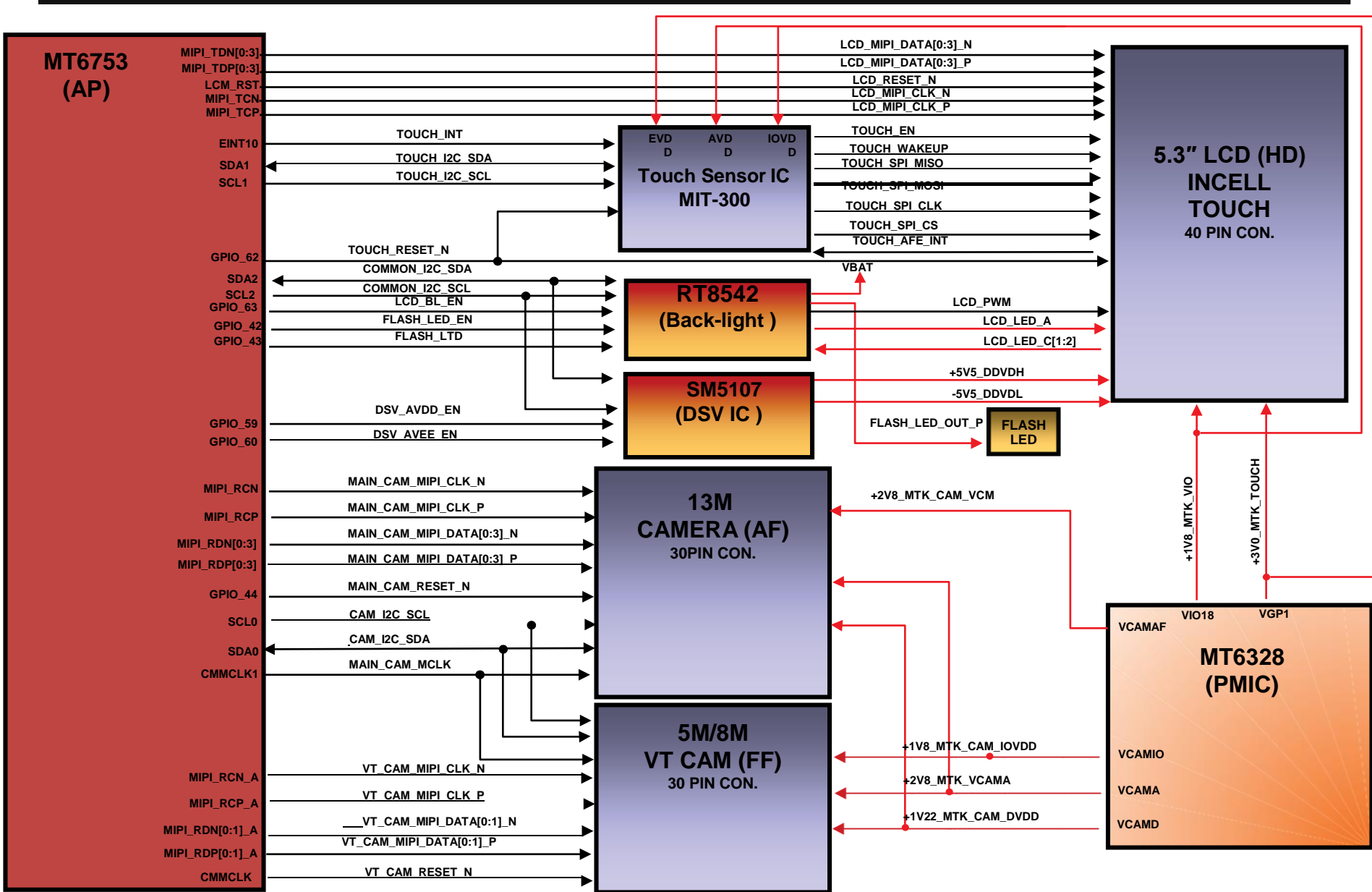

4. BLOCK DIAGRAM

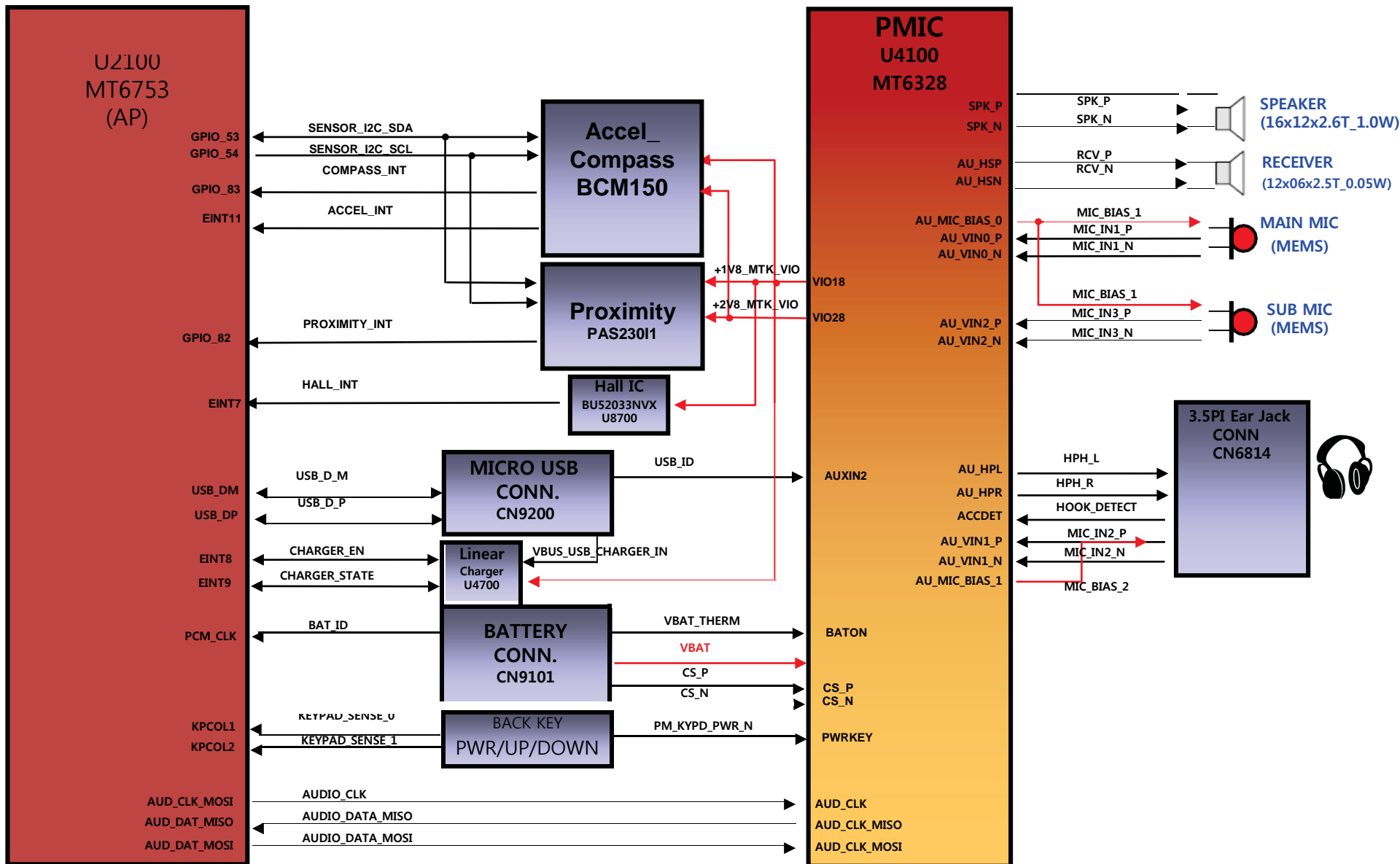

4. BLOCK DIAGRAM

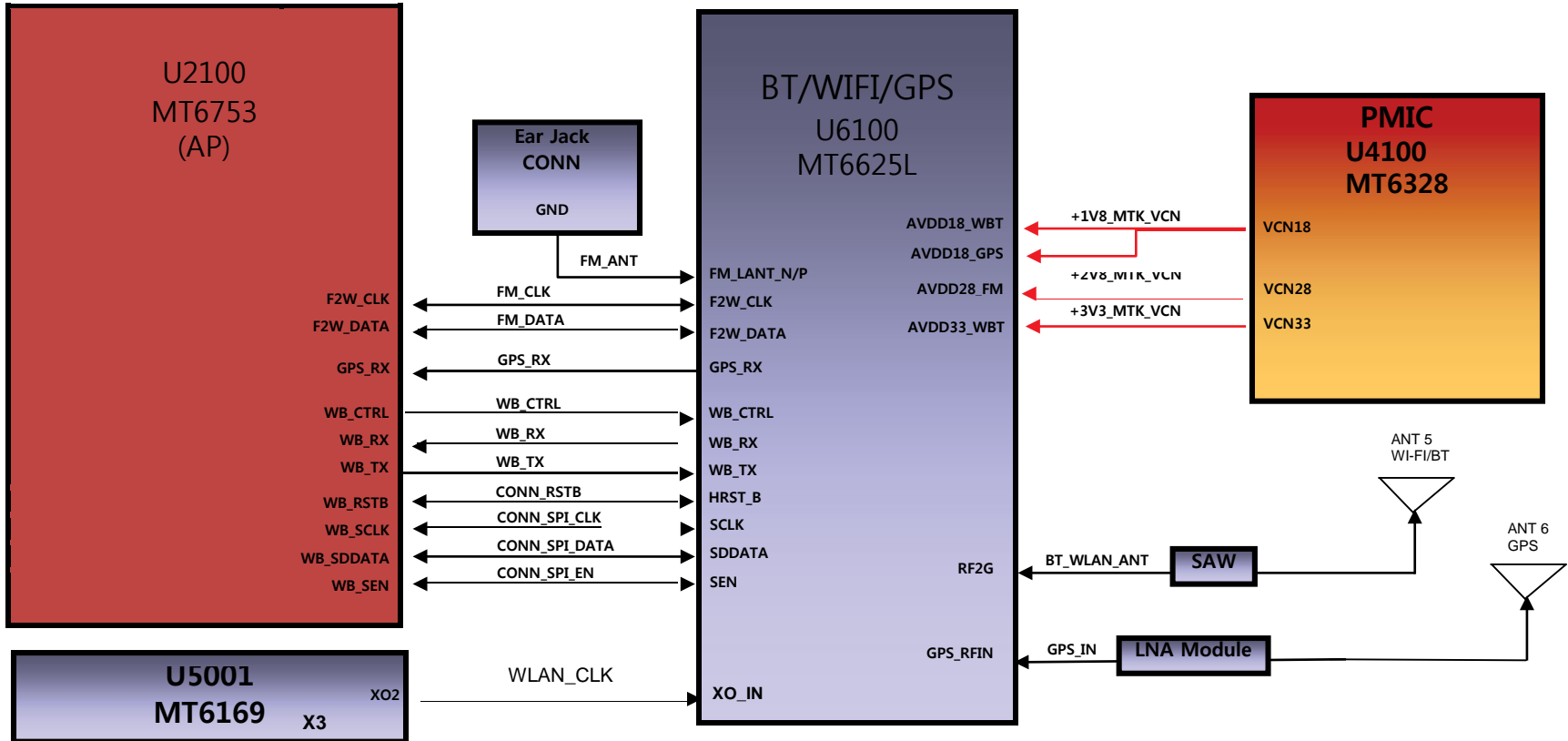

4. BLOCK DIAGRAM

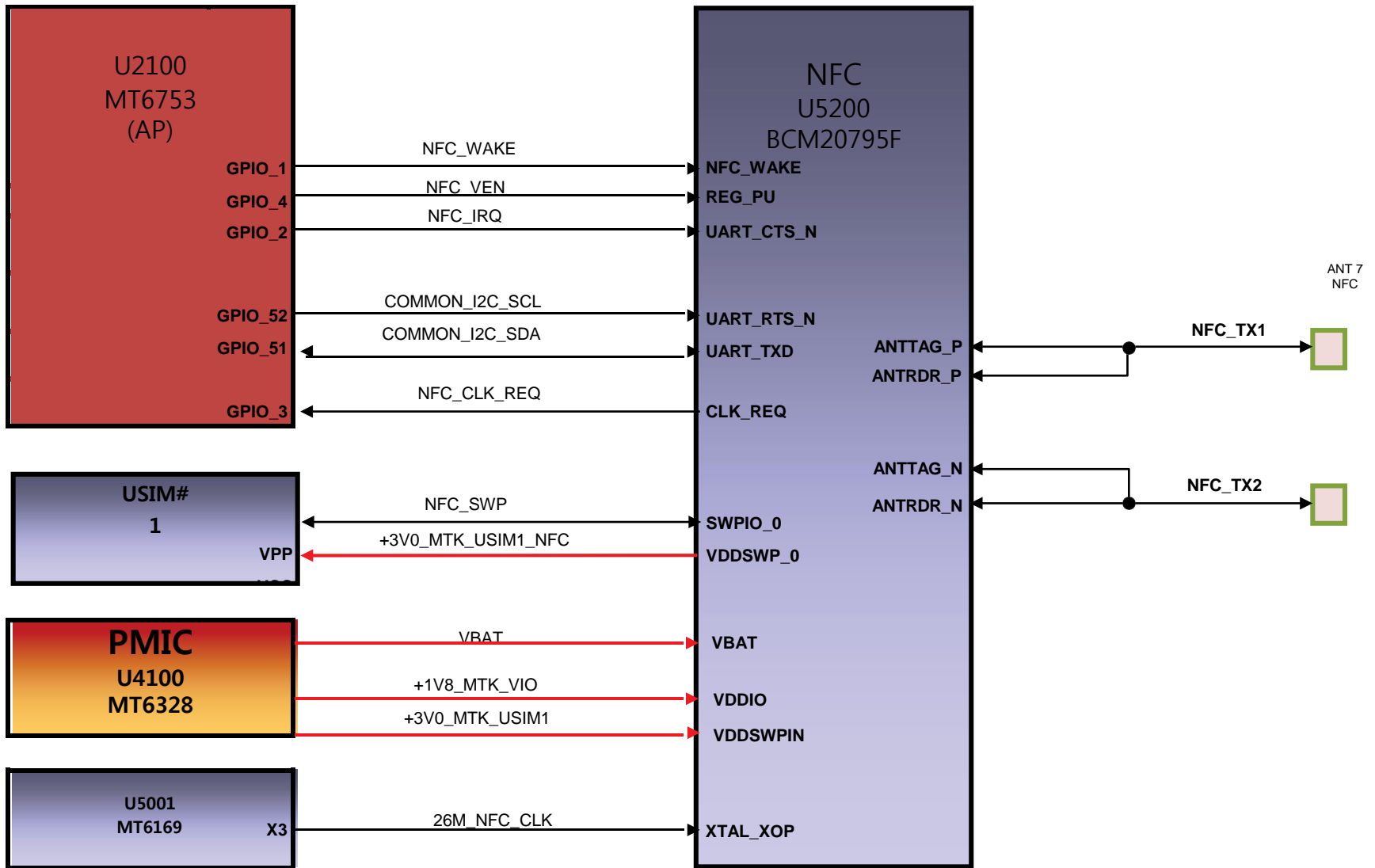

CIRCUIT DIAGRAM

ANT4 (B17/B20/B28 2nd)

ANT2 (G1800/1900, W_B1/B2, LTE_B1/B2/B3/B4/B40)

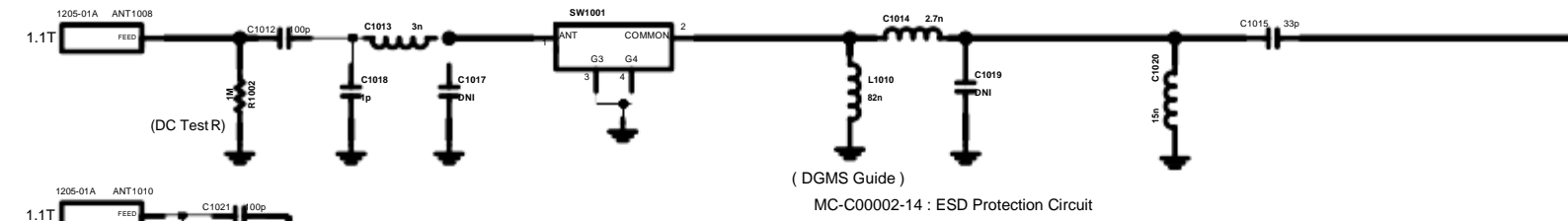

ANT1 (G850/900, W_B5/B8, LTE_B5/B7/B8/B17/B20/B28)

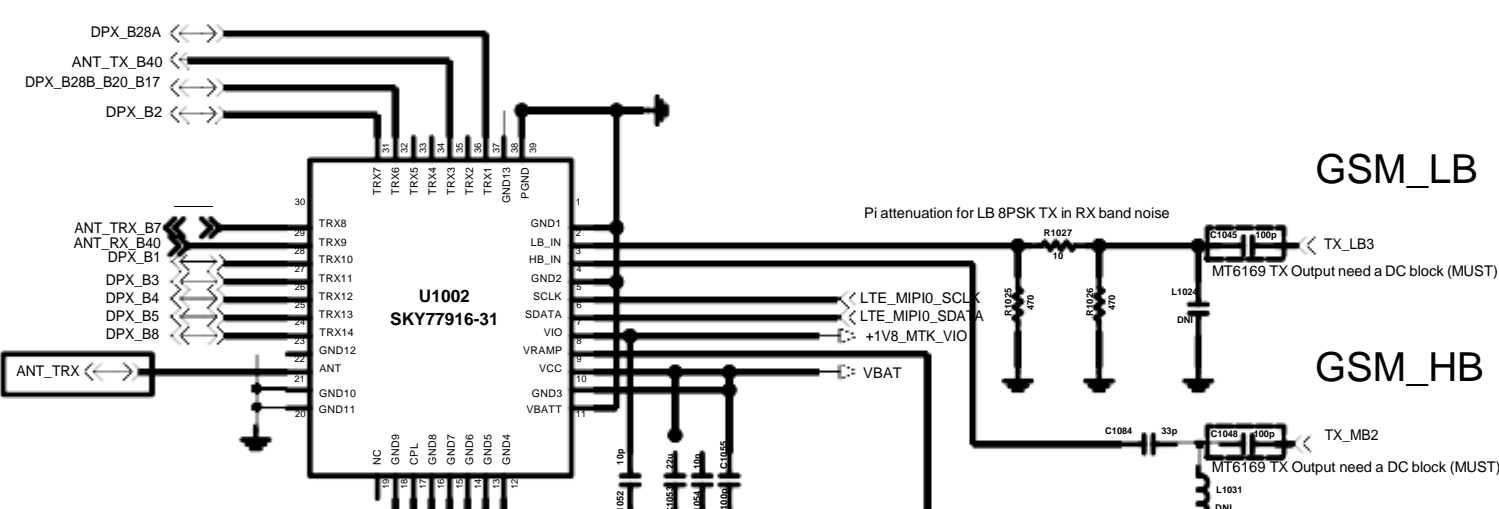
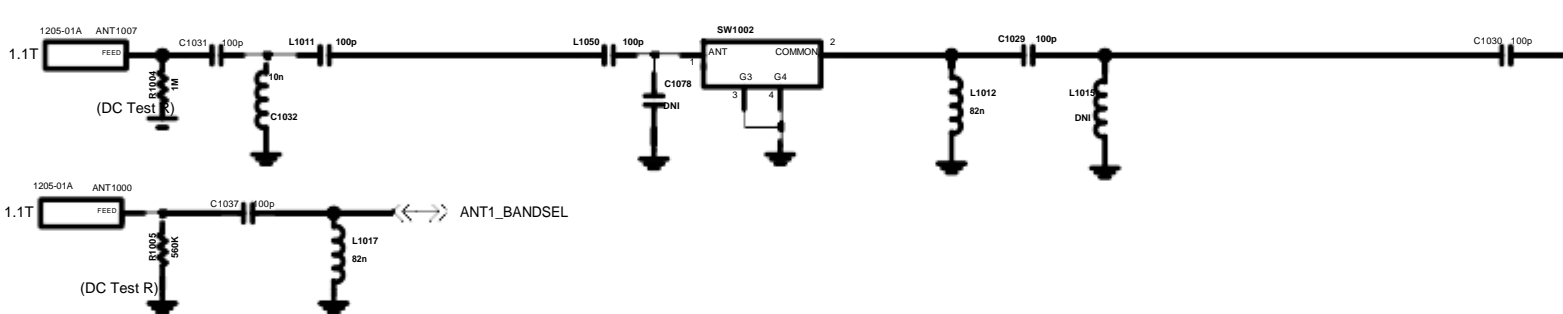

ANT3 (B1/B2/B3/B4/B5/B7/B8/B40 2nd)

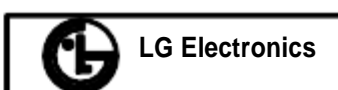
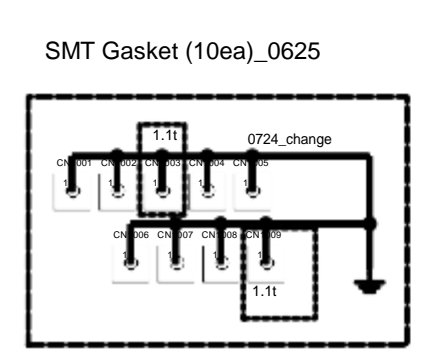
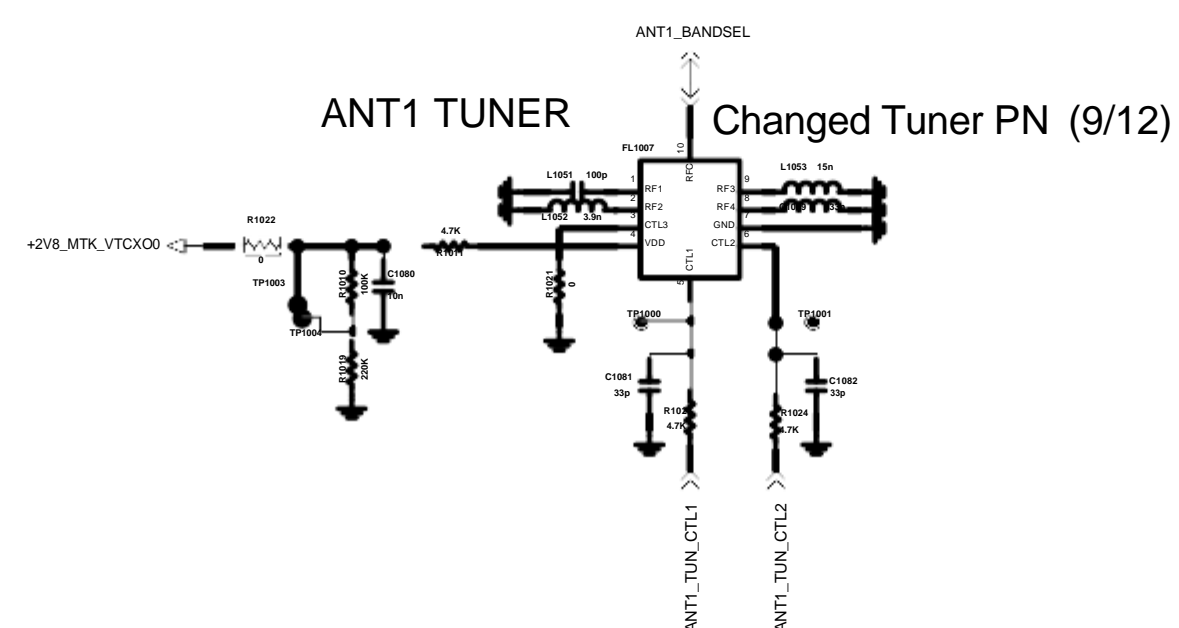
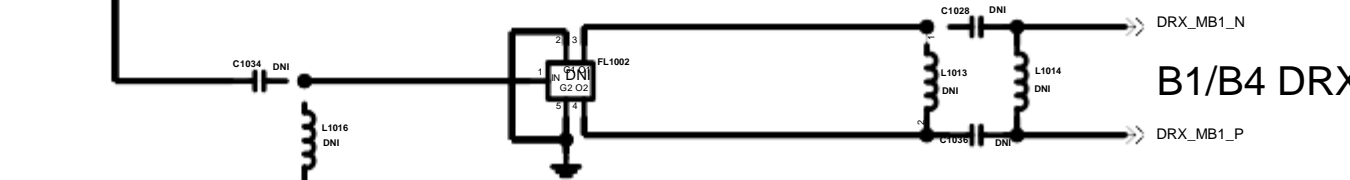
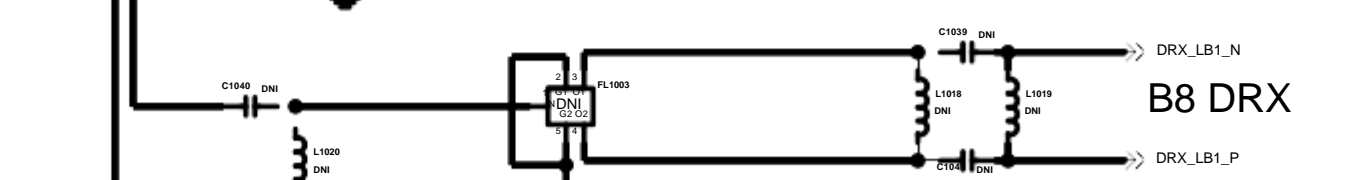
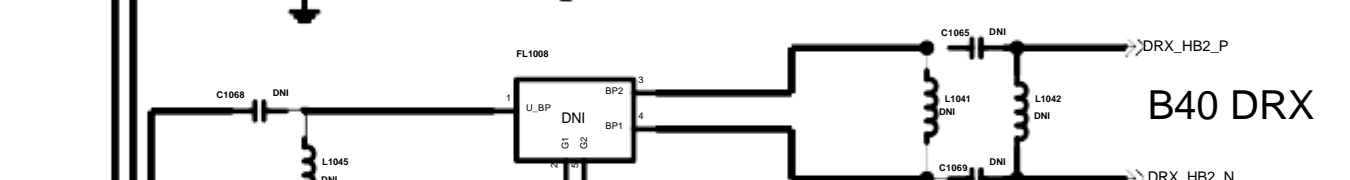
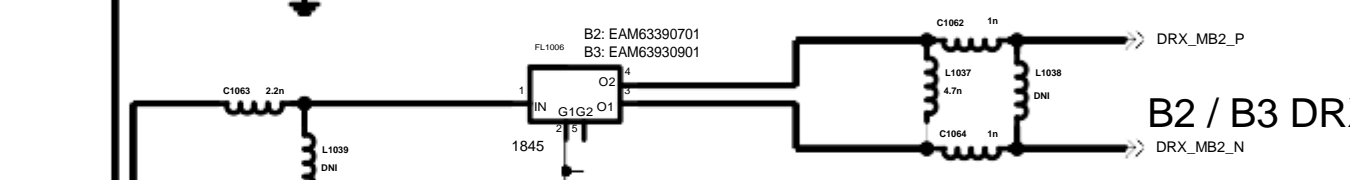
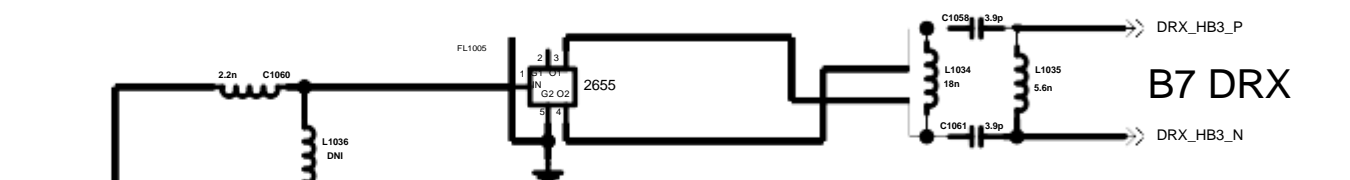
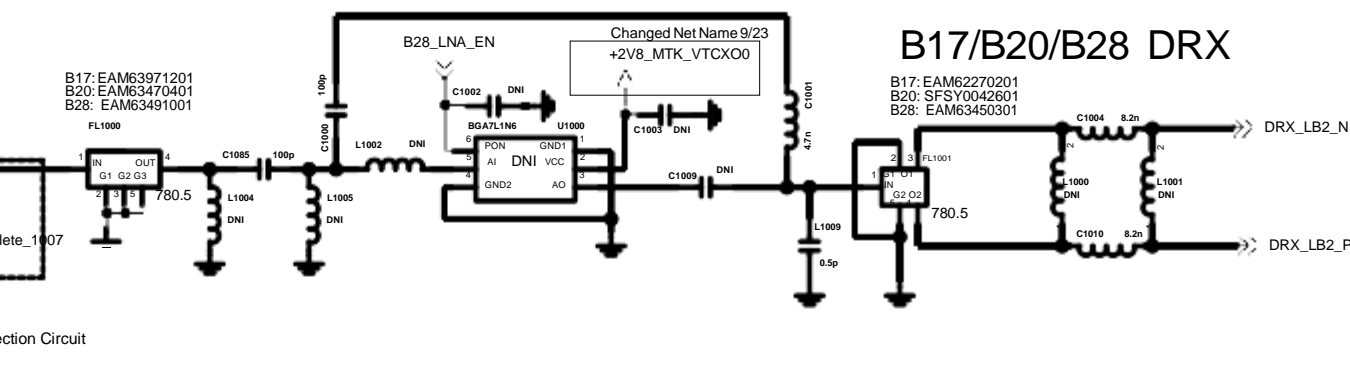
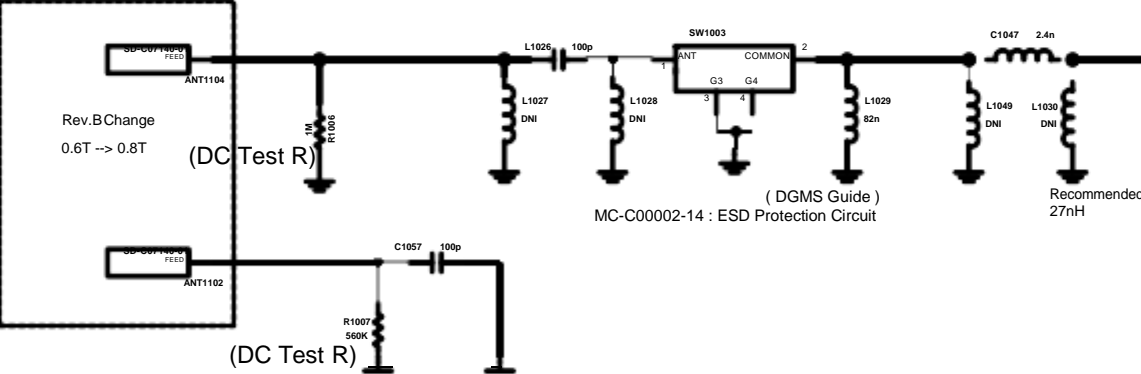

Schematic1

PDMNUMBER Rev

User Name Drawing Date

<1-9-5-1_RFIC_MT6169>

Rev_0.4

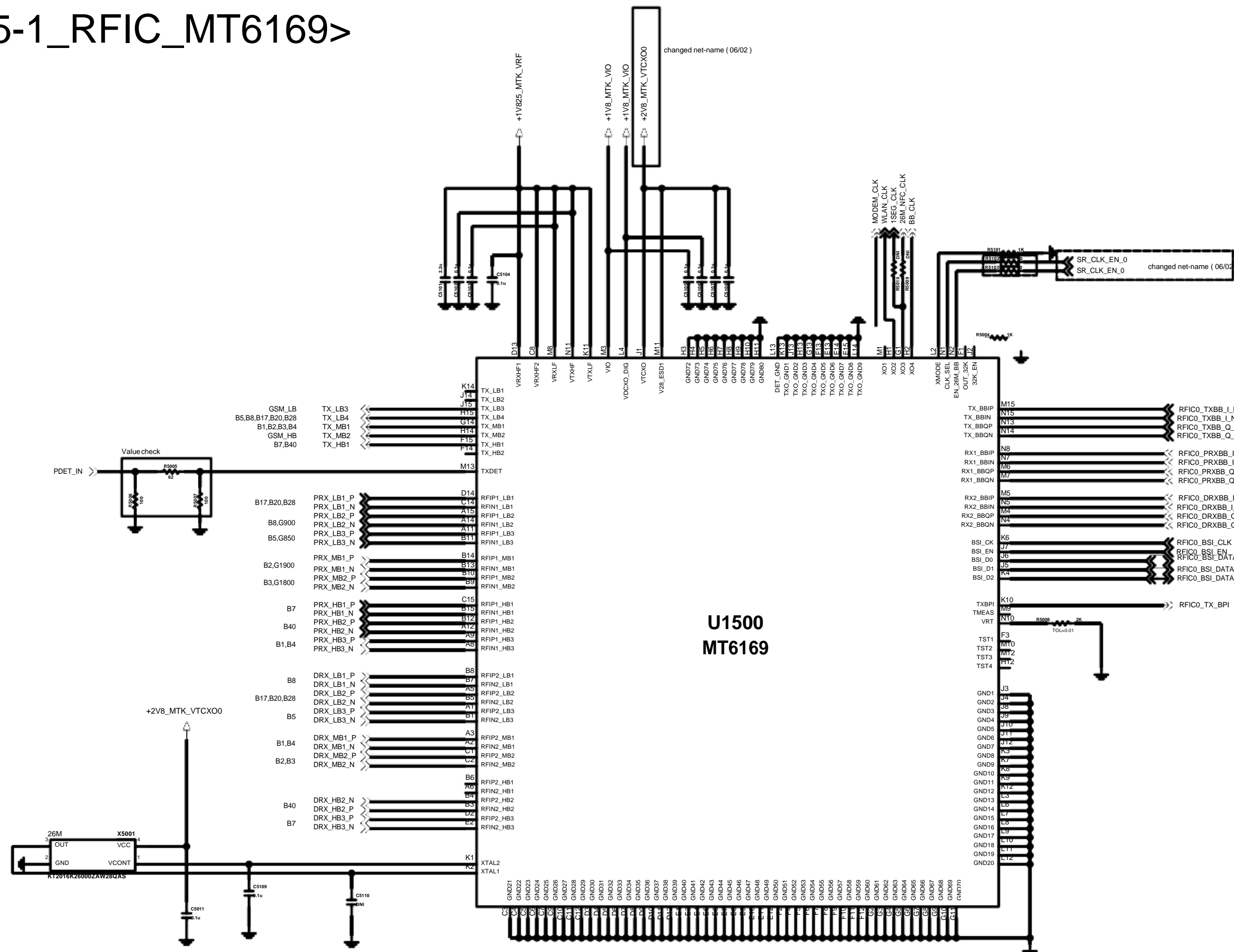

<MT6753 Data>

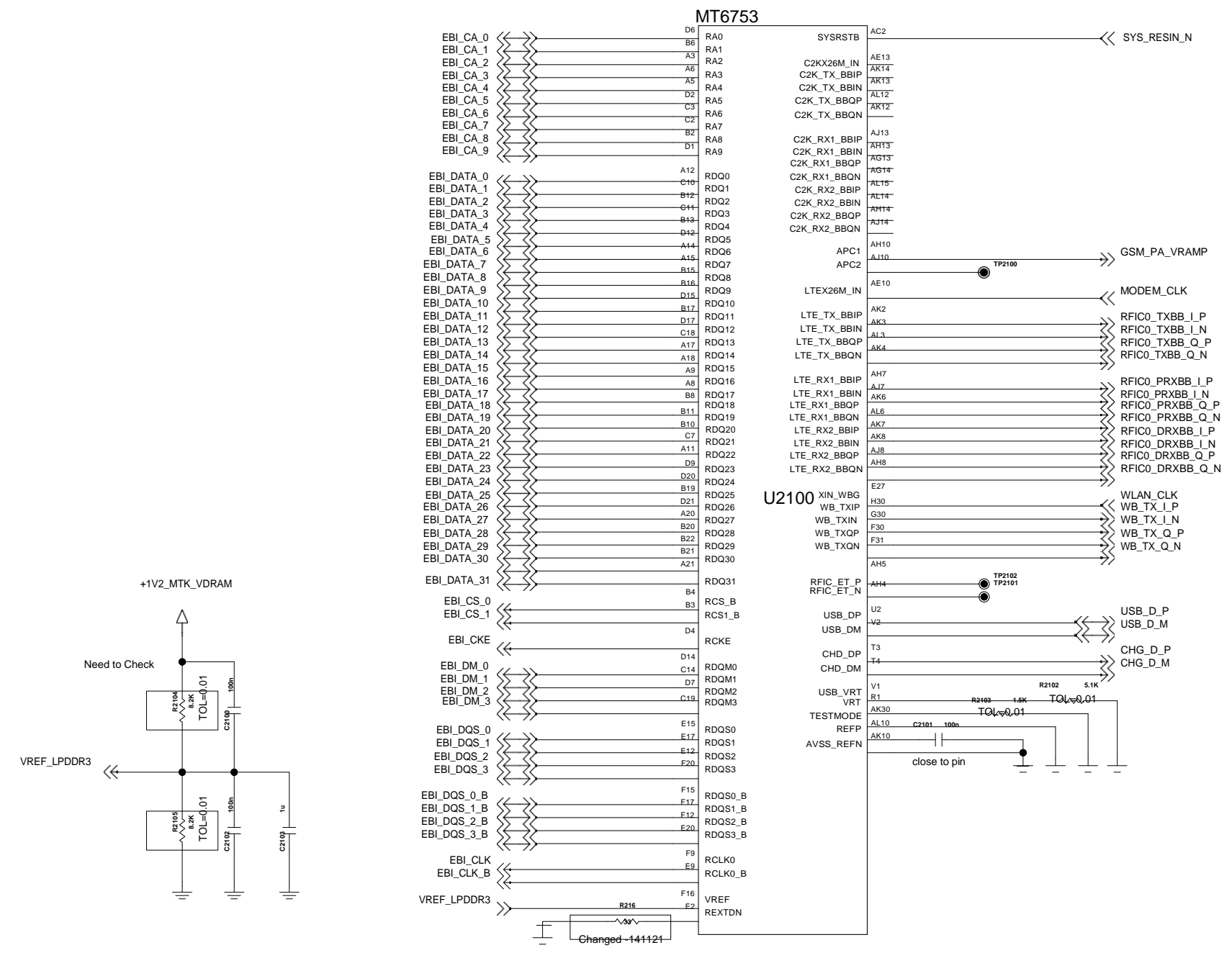

PCB REVISION_GPIO

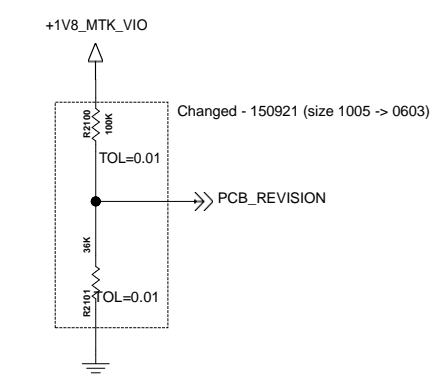

Revision	R2100	R2101	Level
A	100K	20K	0.300
B	100K	27K	0.383
C	DNI	100K	0.000
D	100K	51K	0.680
1.0	100K	36K	0.476
1.1	100K	DNI	1.8

< MT6753_GPIO >

PCB Indicator

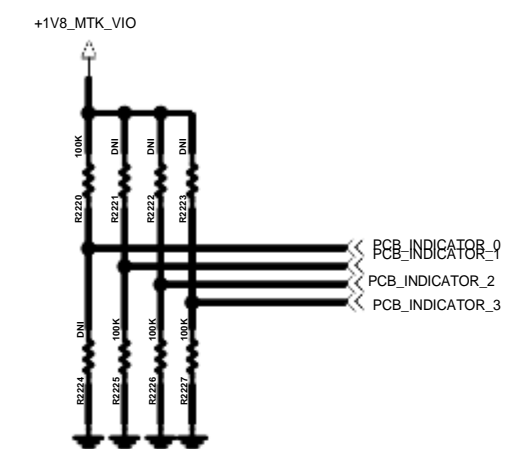

Model Indicator

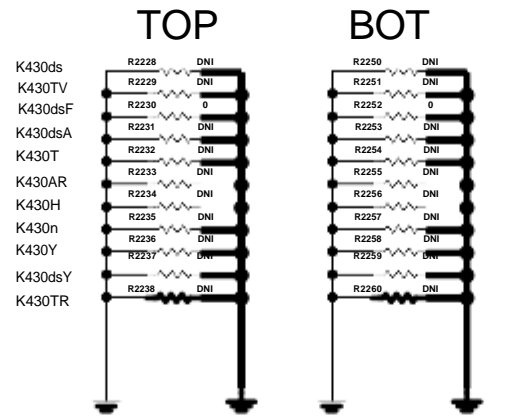

Model	Band	NFC	SIM	GPIO_102	GPIO_101	GPIO_100	GPIO_99	SUM
K430ds	3/7/20	X	Dual	L	L	L	L	0
←-----MMPA REV.B----->								
K430TV	3/7/28	X	Dual	L	H	H	H	5
←-----MMPA REV.B----->								
K430dsF	3/7/28	X	Dual	L	L	L	H	1
K430dsA	3/7/28	X	Dual	L	L	L	H	3
K430T	2/4/5/7/28	X	SINGLE	H	H	H	H	15
K430AR	4/28	X	SINGLE	H	L	L	H	9
K430H	2/4/5/7/17	X	SINGLE	H	L	H	H	11
K430n	1/3/7/8/40	U	SINGLE	H	H	H	L	14
K430Y	1/3/5/7/8	X	SINGLE	H	L	H	L	10
K430dsY	1/3/5/7/8/28/40	X	Dual	L	L	H	L	2
K430TR	1/3/7/8/20	X	SINGLE	H	L	L	L	8

Indicator_3 : Dual SIM/Single SIM
 Indicator_2 : 1Seg/NFC/etc
 Indicator_1 : Band/CG_B4/40(TDD)/Memory(1G/8G)
 Indicator_0 : A0_#
 Indicator_2&1 : MMPA REVISION #*#D

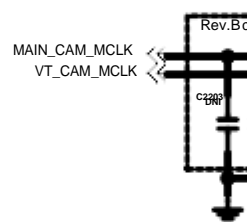

< 9-3-1_JTAG > Rev_0.4

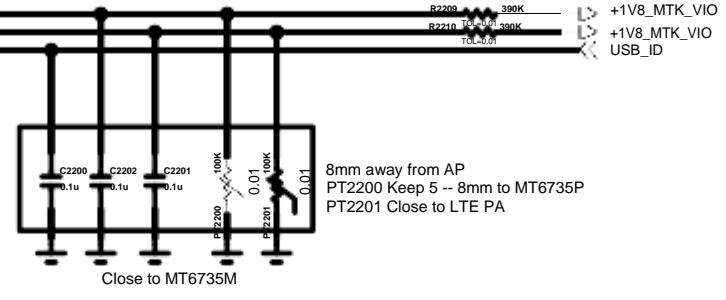
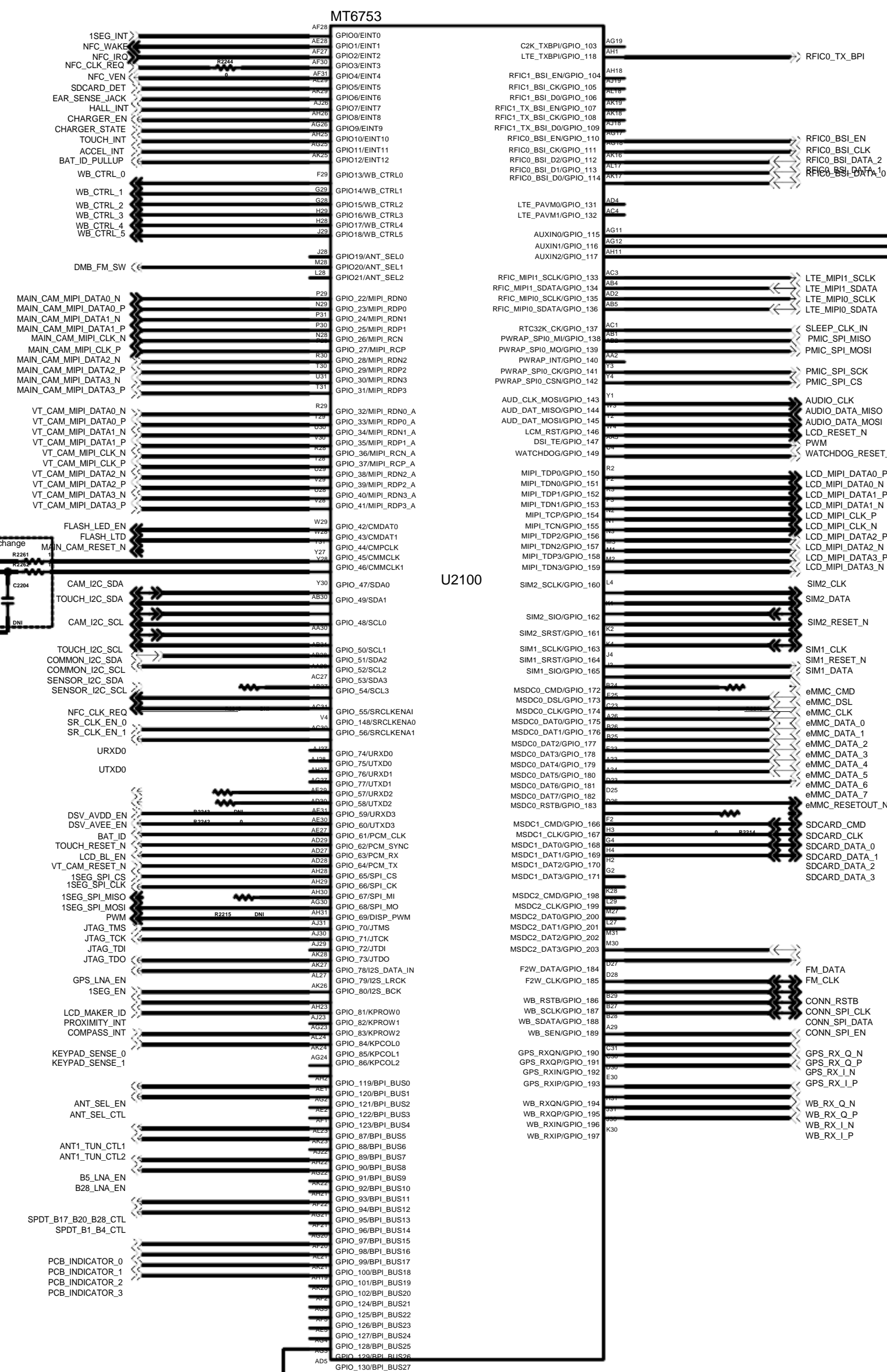
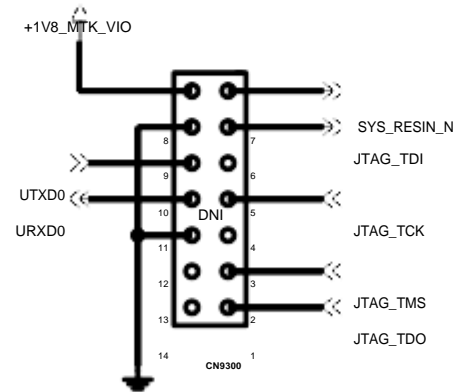

I2C Pull-Up

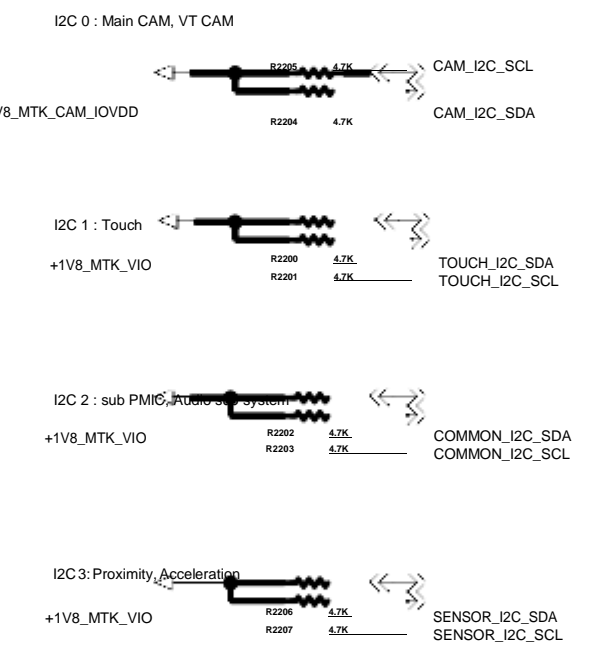

LOW : Externl VLTE_SRAM Buck disable

<MT6753_POWER >

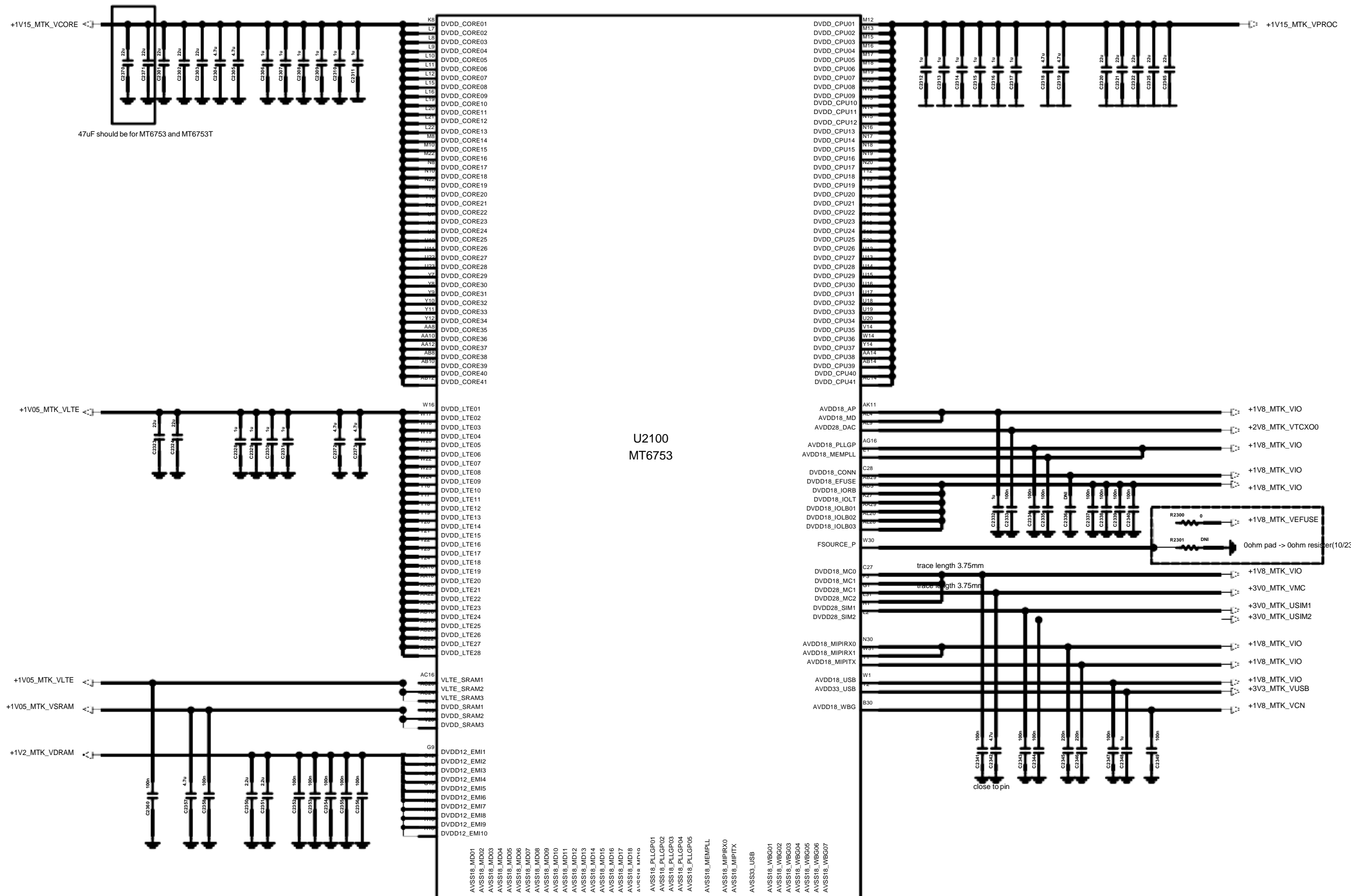

U2100
MT6753

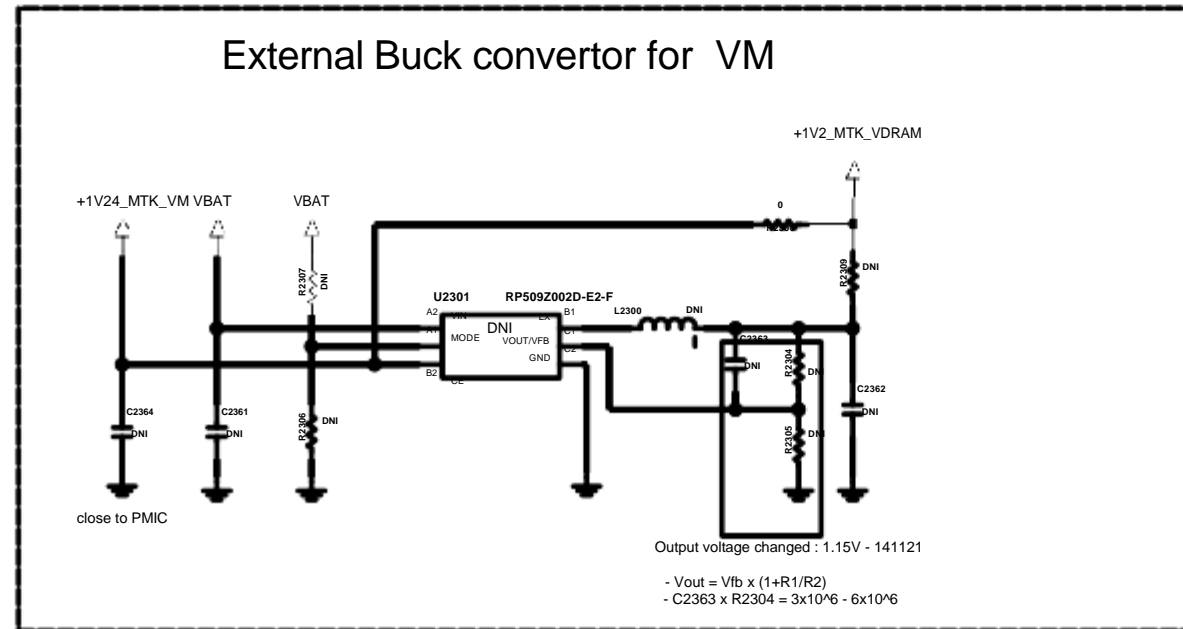

16

15

14

13

12

11

10

9

8

7

6

5

4

3

2

1

< MT6753_GND >

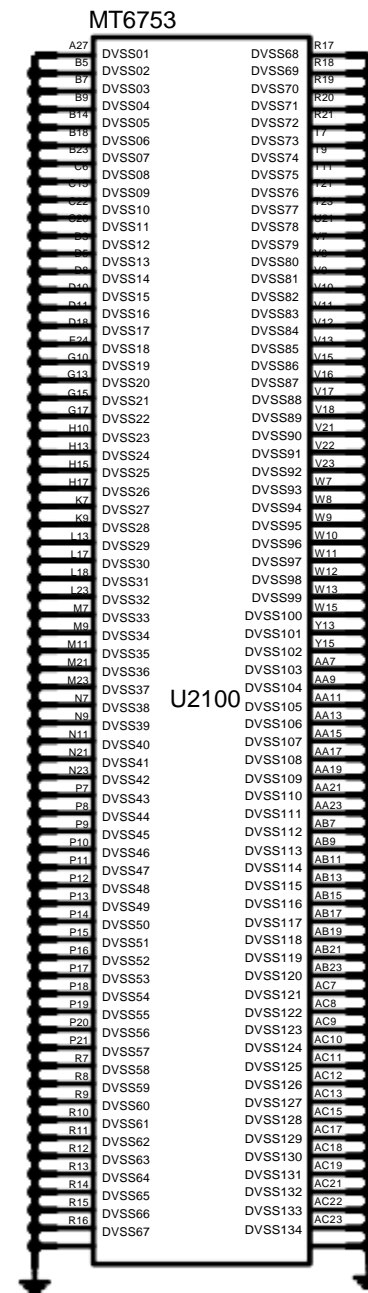
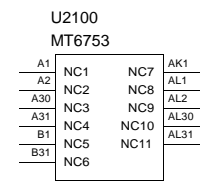

U2100

LG Electronics

Schema1

DATE: 2014.08.20

DESIGNER: [Name]

APP: [Name]

REV: 1

< 3-3-3_MCP_eMMC_5_0_1.5G_DDR3_16G_eMMC Samsung > Rev_0.3

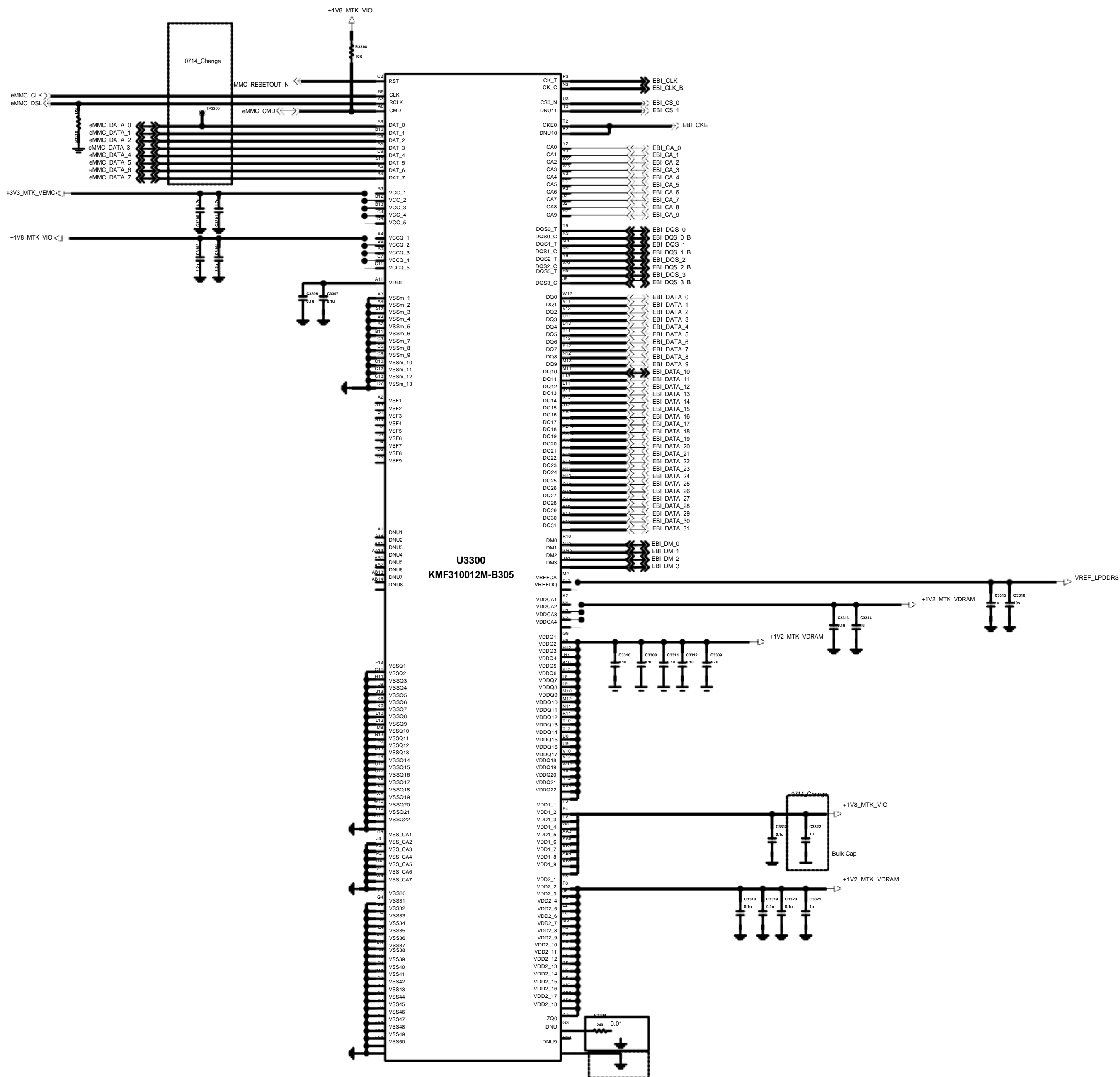

KEEP CLOSE TO THE PIN

< MT6328_DATA >

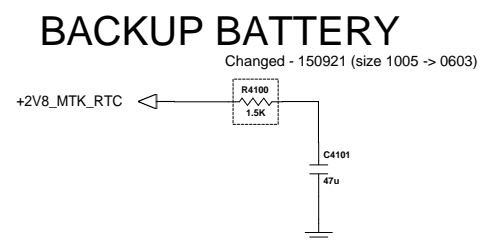
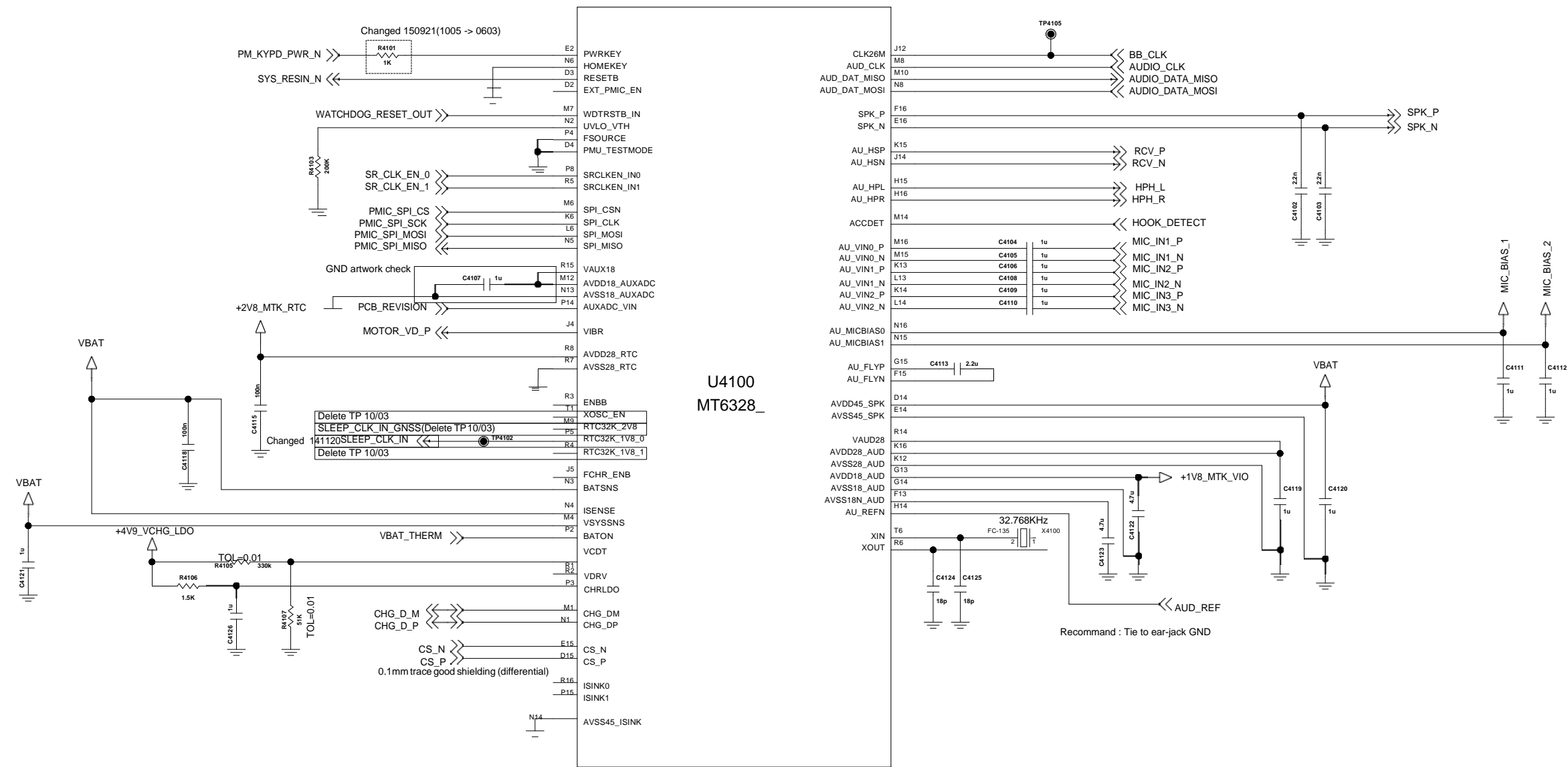

< MT6328_POWER >

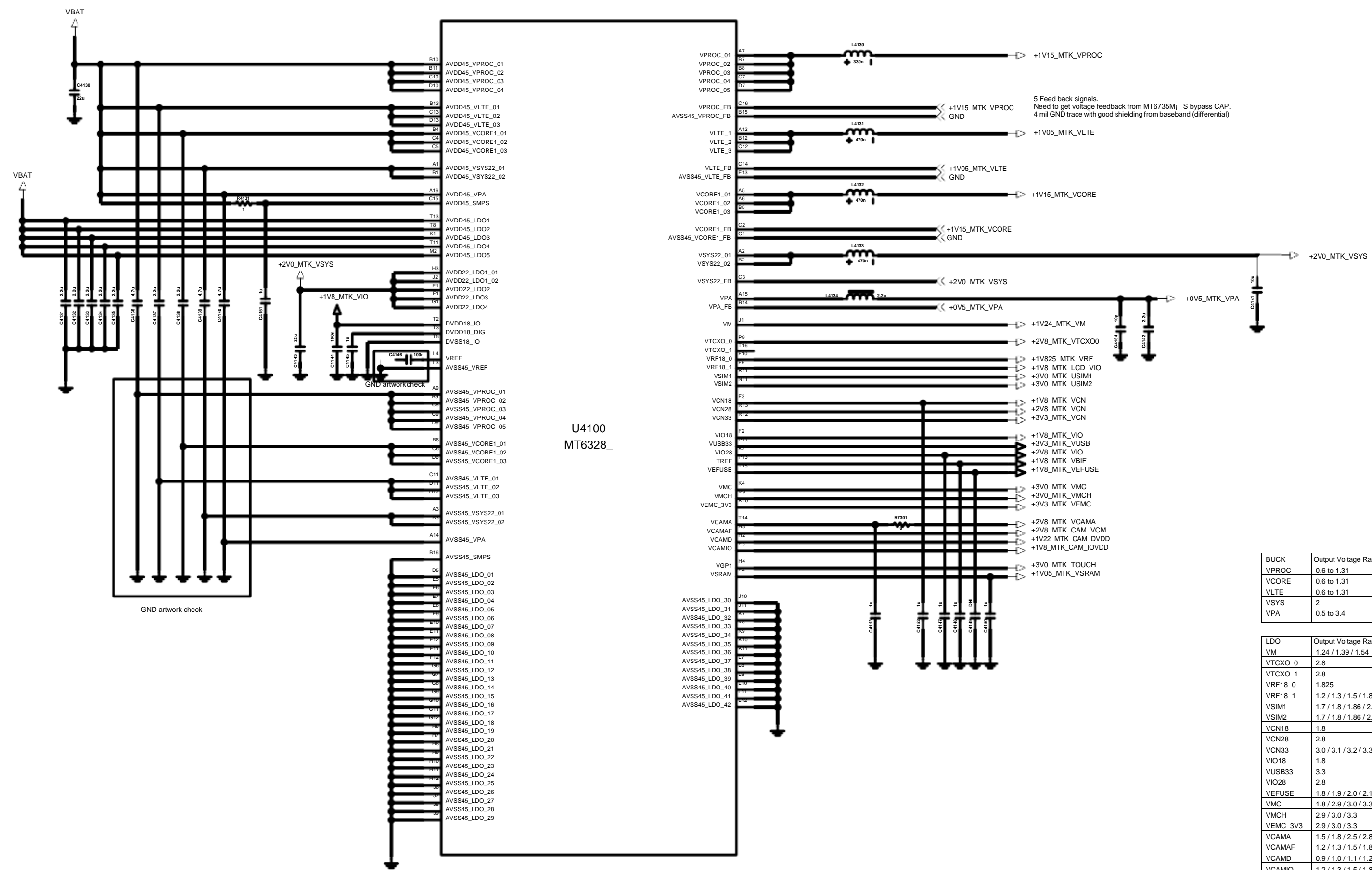

5 Feed back signals.
Need to get voltage feedback from MT6735M S bypass CAP.
4 mil GND trace with good shielding from baseband (differential)

BUCK	Output Voltage Range(V)	Output Current(mA)
VPROC	0.6 to 1.31	5000
VCORE	0.6 to 1.31	3500
VLTE	0.6 to 1.31	2800
VSYS	2	1900
VPA	0.5 to 3.4	600

LDO	Output Voltage Range(V)	Output Current(mA)
VM	1.24 / 1.39 / 1.54	1000
VTCXO_0	2.8	40
VTCXO_1	2.8	40
VRF18_0	1.825	350
VRF18_1	1.2 / 1.3 / 1.5 / 1.825	300
VSIM1	1.7 / 1.8 / 1.86 / 2.76 / 3.0 / 3.1	50
VSIM2	1.7 / 1.8 / 1.86 / 2.76 / 3.0 / 3.1	50
VCN18	1.8	150
VCN28	2.8	40
VCN33	3.0 / 3.1 / 3.2 / 3.3 / 3.4 / 3.5 / 3.6	350
VIO18	1.8	600
VUSB33	3.3	20
VIO28	2.8	200
VEFUSE	1.8 / 1.9 / 2.0 / 2.1 / 2.2	200
VMC	1.8 / 2.9 / 3.0 / 3.3	200
VMCH	2.9 / 3.0 / 3.3	800
VEMC_3V3	2.9 / 3.0 / 3.3	400
VCAMA	1.5 / 1.8 / 2.5 / 2.8	200
VCAMAF	1.2 / 1.3 / 1.5 / 1.8 / 2.0 / 2.8 / 3.0 / 3.3	200
VCAMD	0.9 / 1.0 / 1.1 / 1.22 / 1.3 / 1.5	500
VCAMIO	1.2 / 1.3 / 1.5 / 1.8	200
VGP1	1.2 / 1.3 / 1.5 / 1.8 / 2.5 / 2.8 / 3.0 / 3.3	200
VSRAM	0.6 to 1.31	400
VIBR	1.2 / 1.3 / 1.5 / 1.8 / 2.0 / 2.8 / 3.0 / 3.3	100
VAUX18	1.8	40
VAUD28	2.8	40
DVDD18_DIG	1.8	20
VRTIC	2.8	2

<5-1-1-18_MT6625L_WiFi_BT_GPS_FM>

Rev_0.3

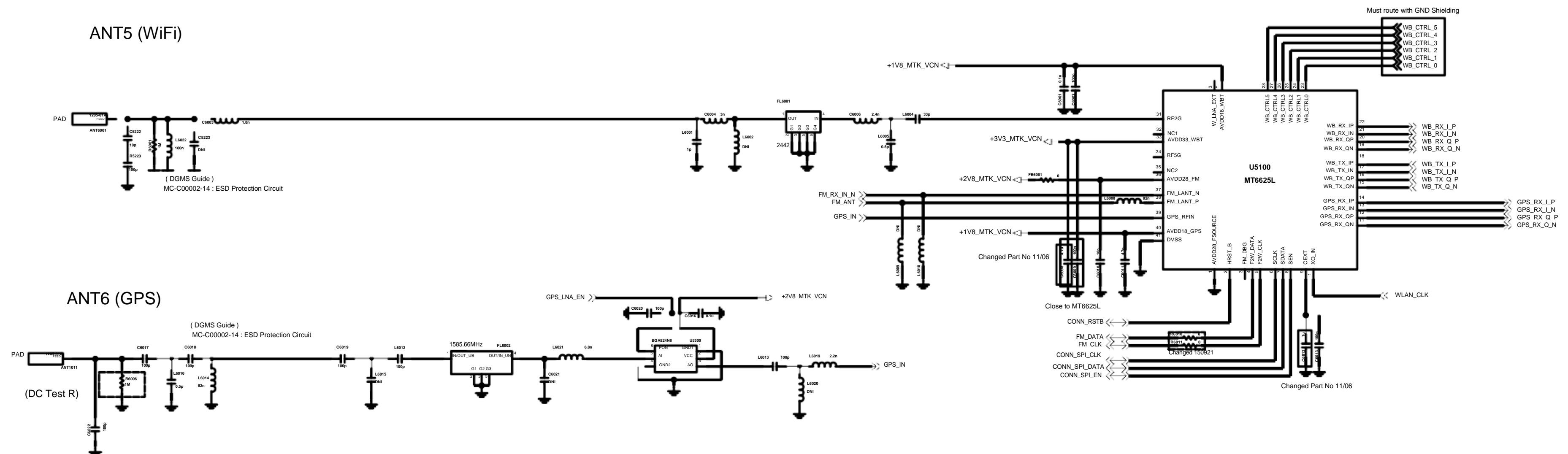

<5-2-1-8_BCM20795F> Rev_1.0

NFC Antenna

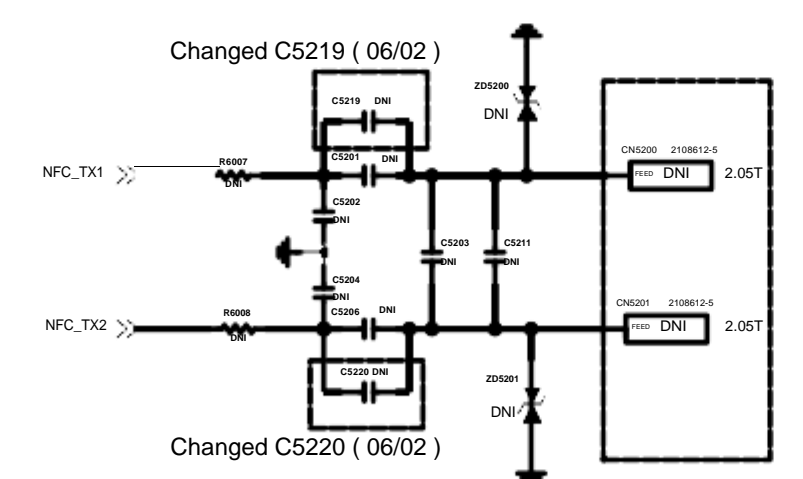
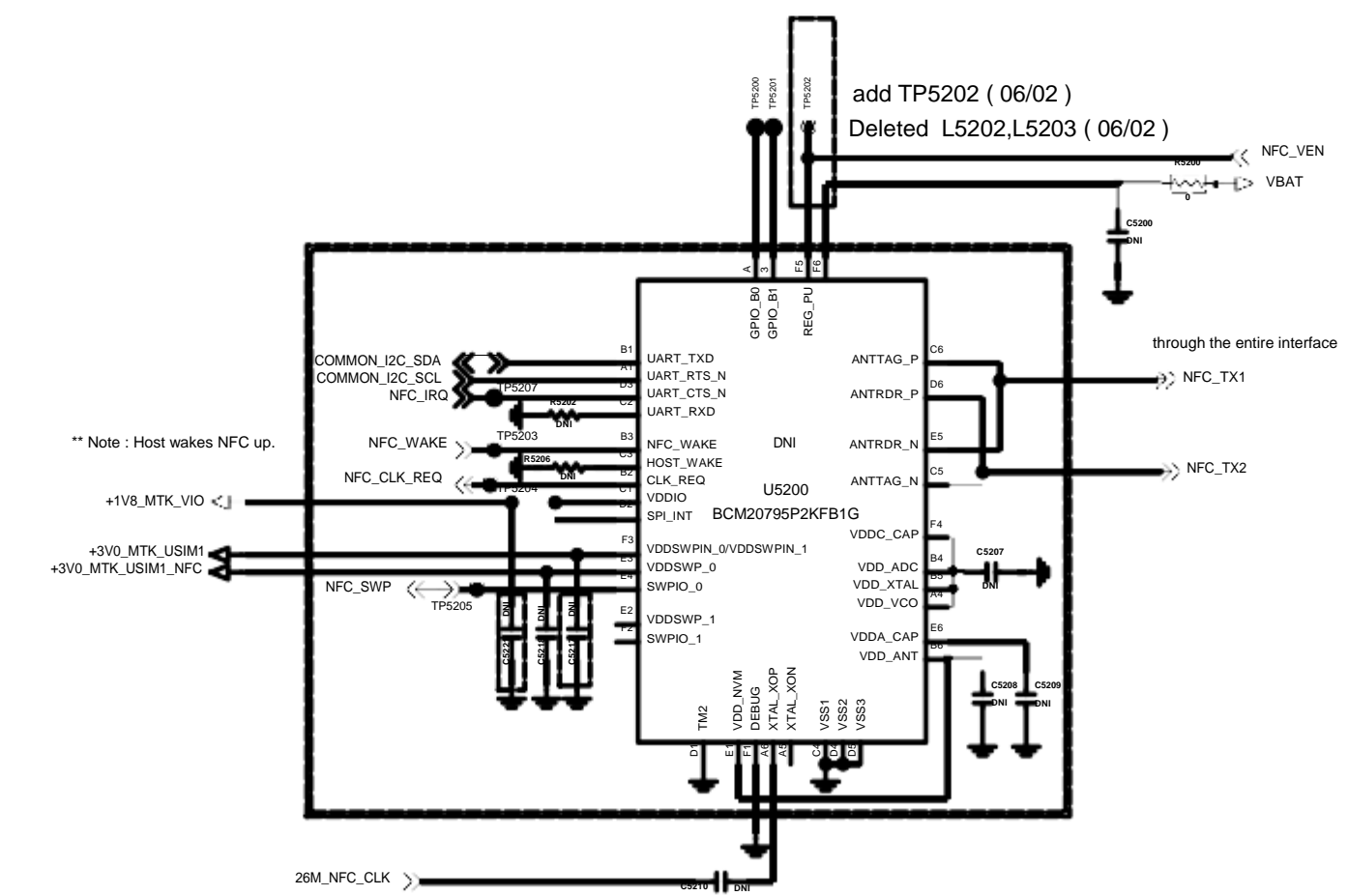

<Only for LATAM>

<5-3-1-6_One_SEG_FC8180> Rev_1.0

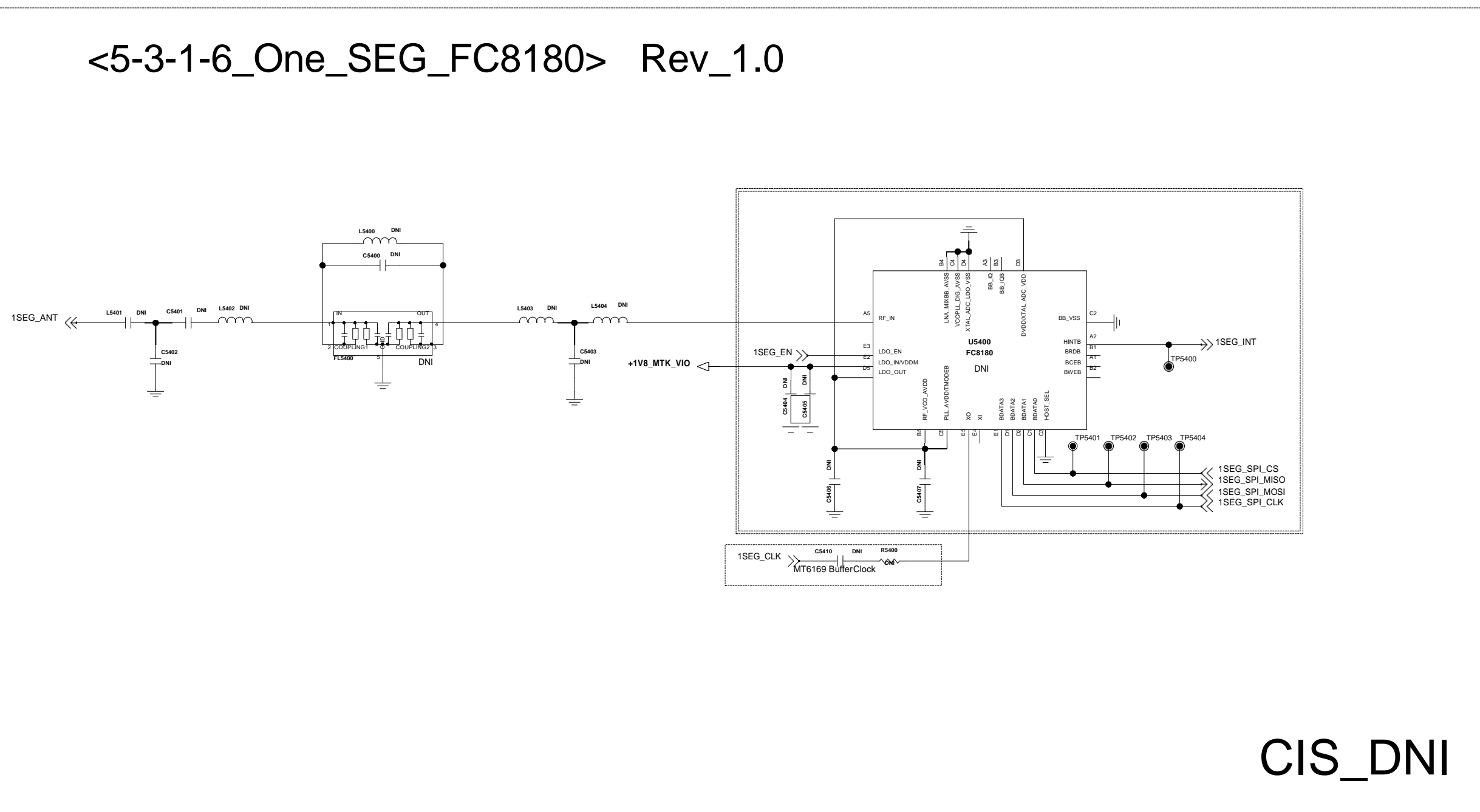

CIS_DNI

<4-4-3_LCD_Backlight_IC_RT8542> Rev_1.2

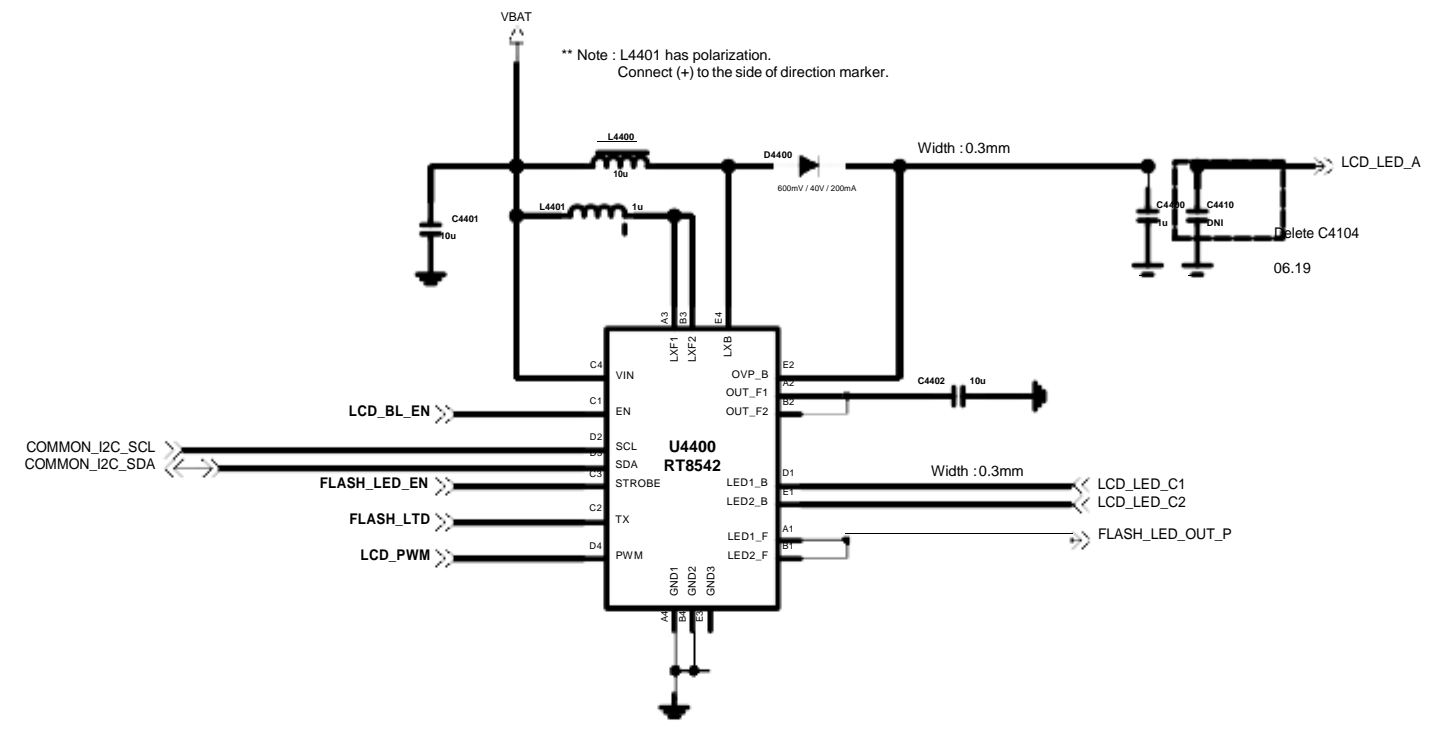

< Camera Flash LED >

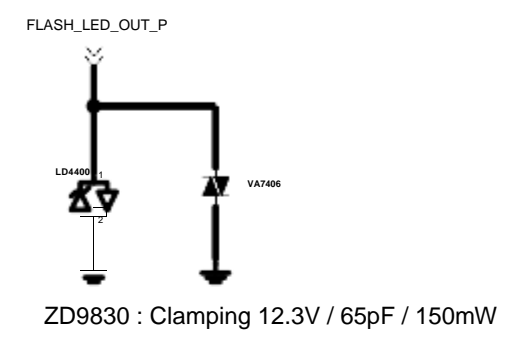

<DSV_SM5107>

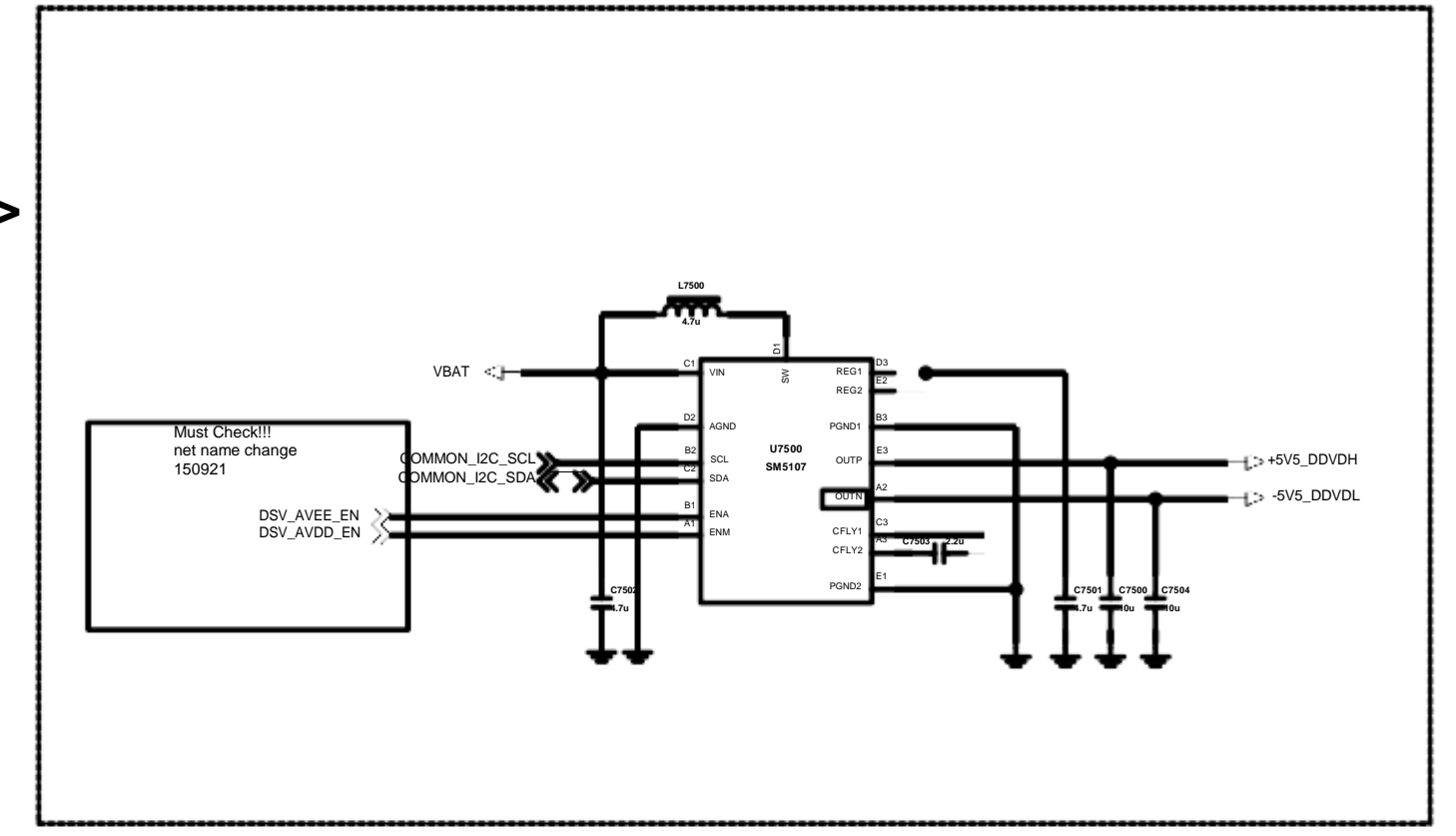

5.3" Incell LCD Connector

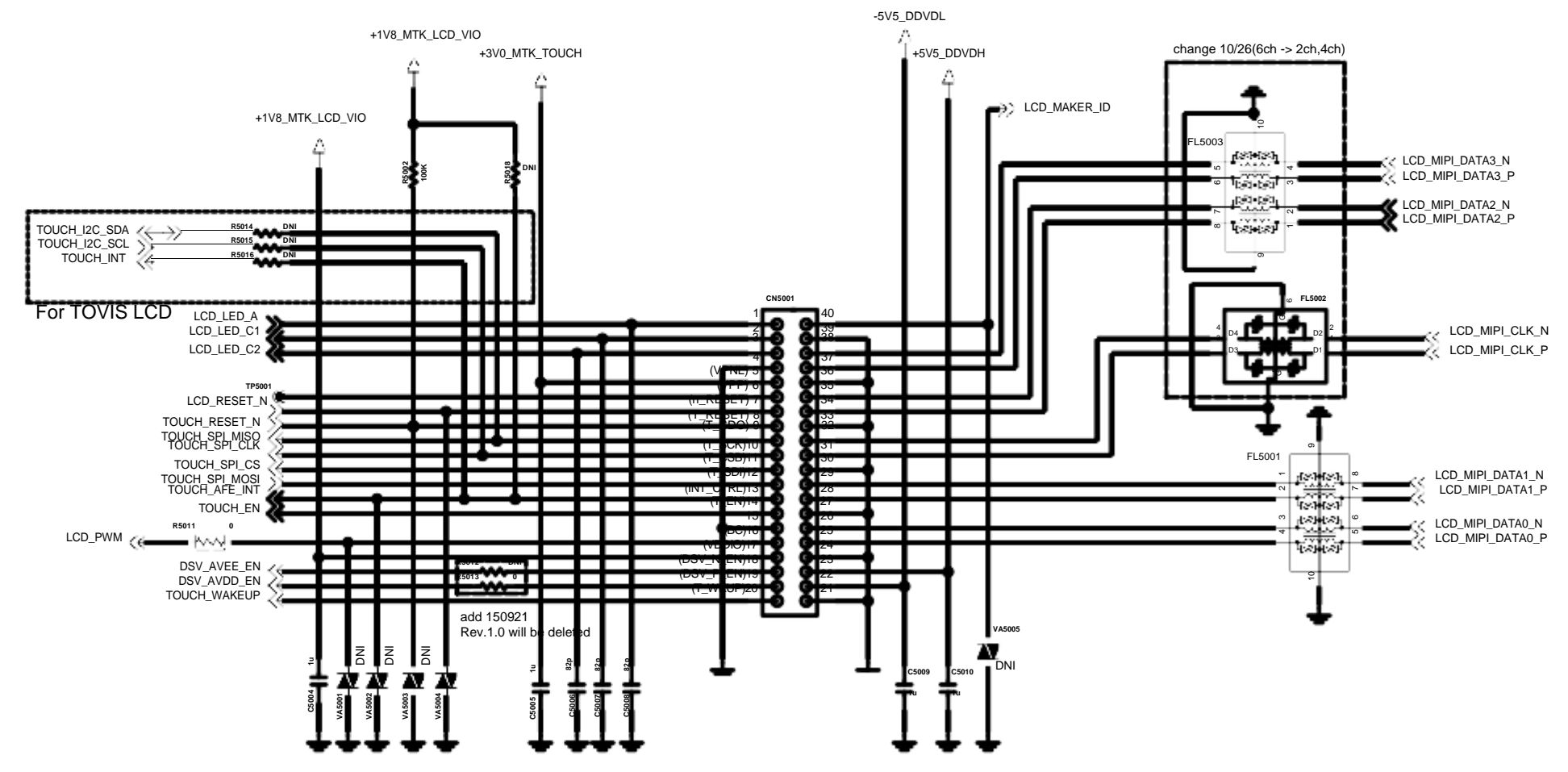

TOUCH IC

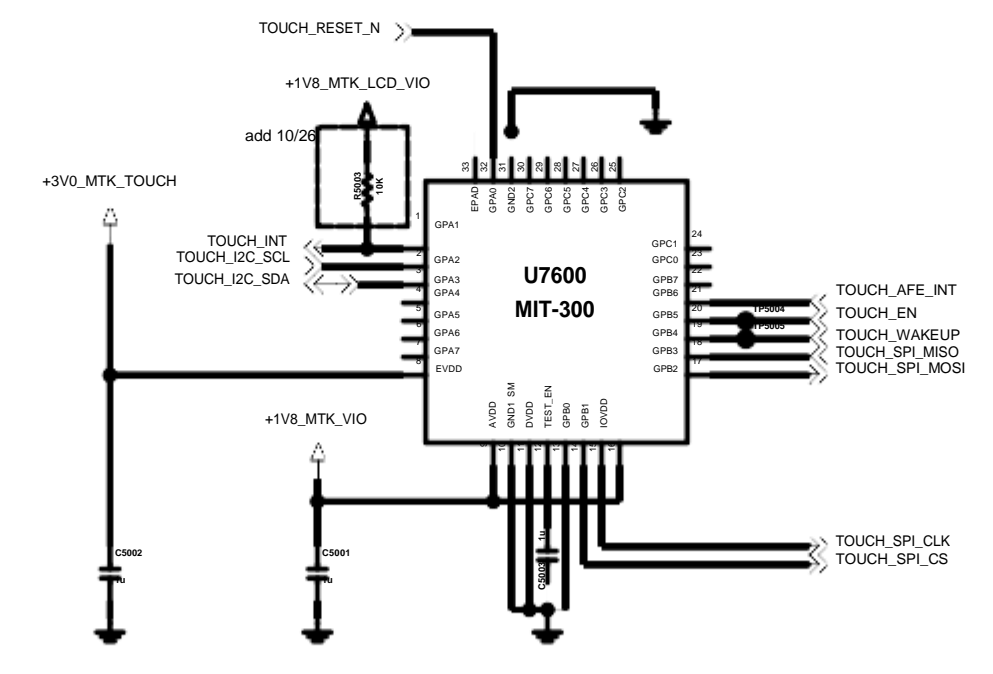

L
K
J
I
H
G
F
E
D
C
B
A

L
K
J
I
H
G
F
E
D
C
B
A

< 7-3_Main_Camera > Rev_1.2

<VT Camera>

Camera 5. 30pin 8M & 13 AF

Option 5M/8M Change Pin Map(30Pin)

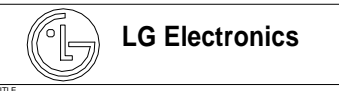
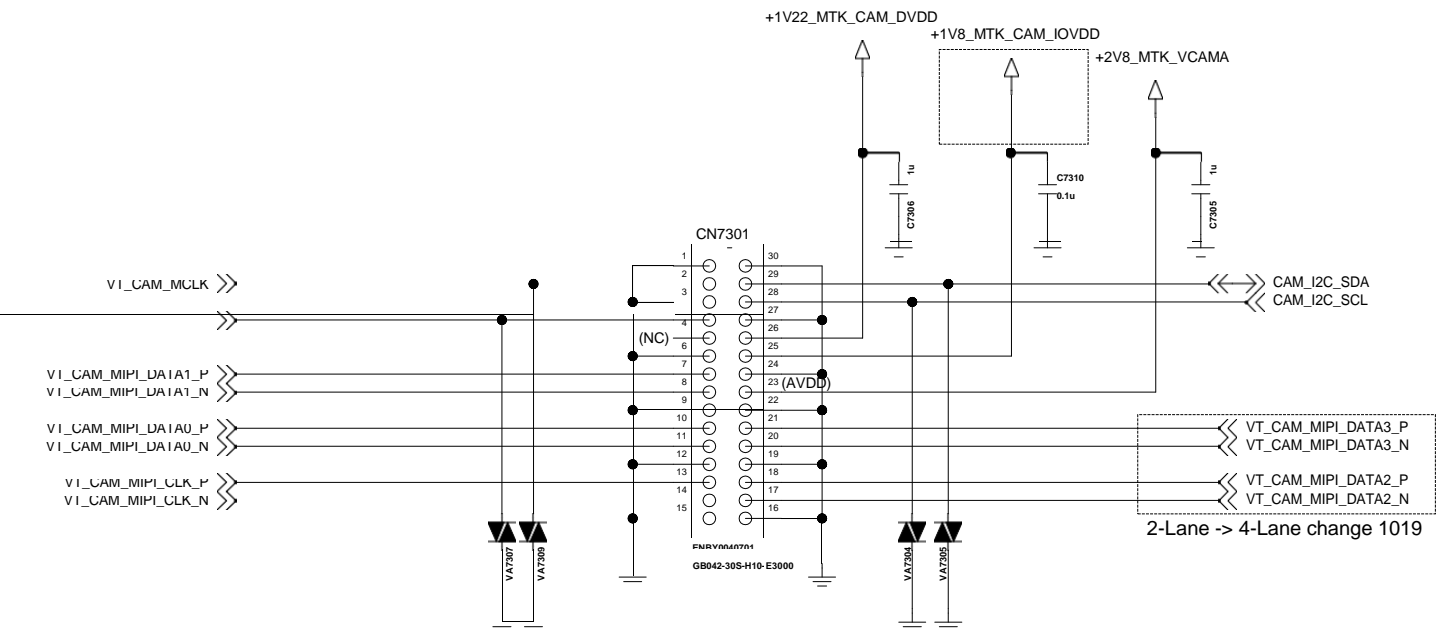
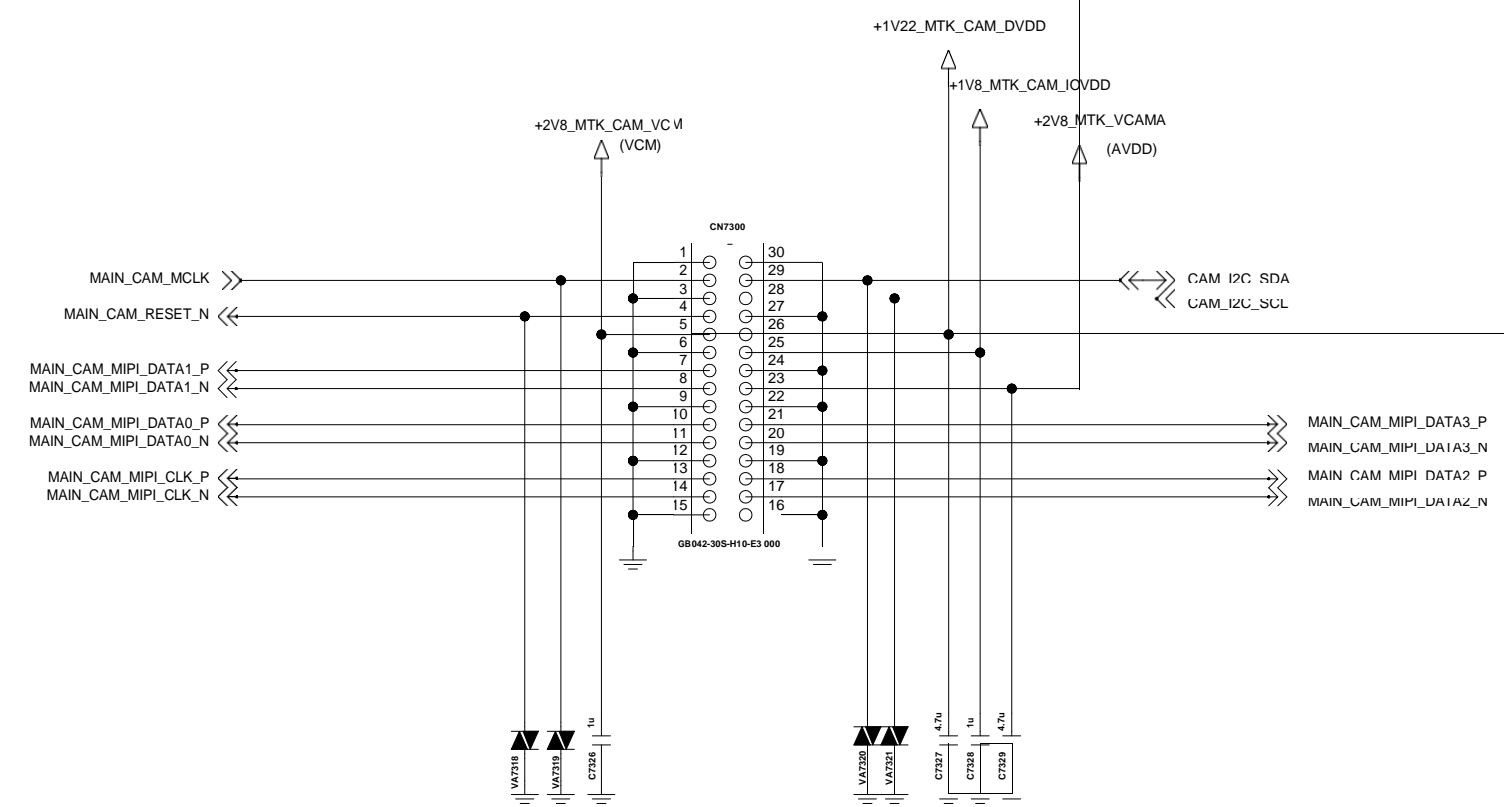

Schematic1

REV	DATE	BY	CHK	APP
A2	24	24		

< 6-7-1_Speaker > Rev_1.2

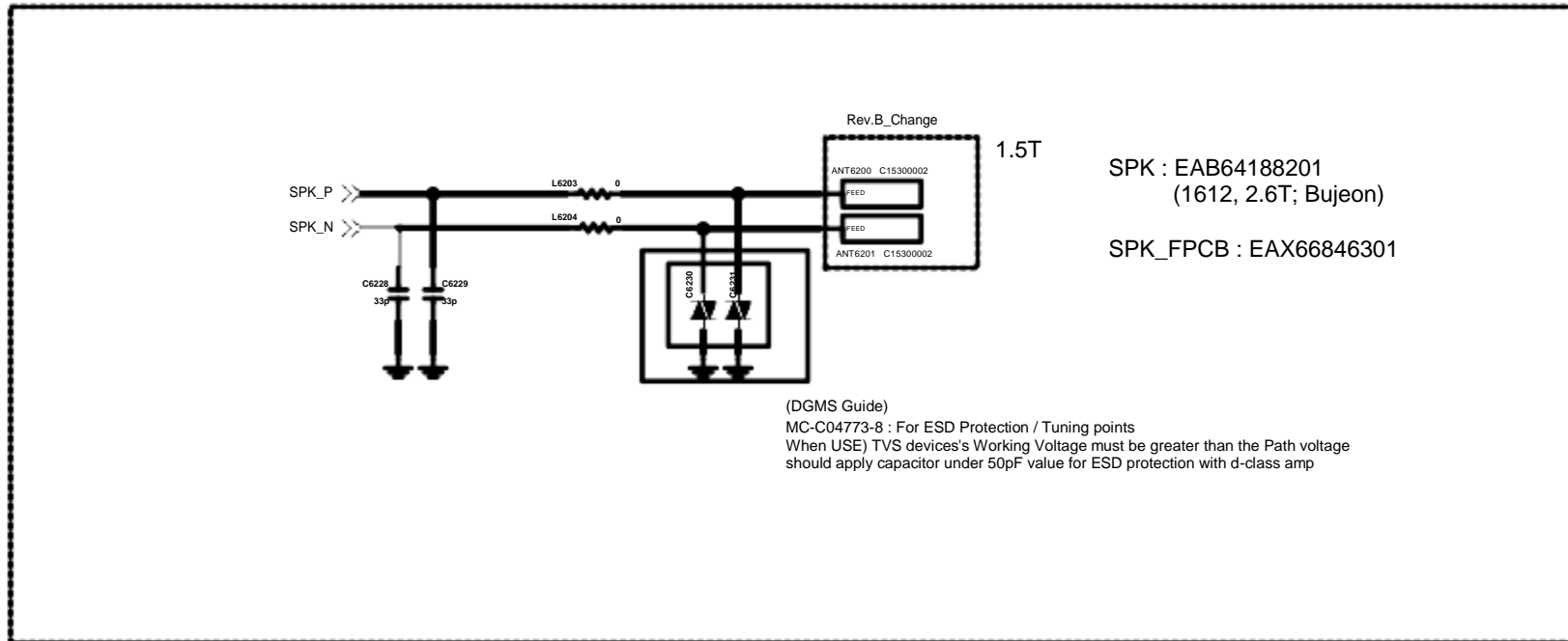

< 6-6-1_Earjack >

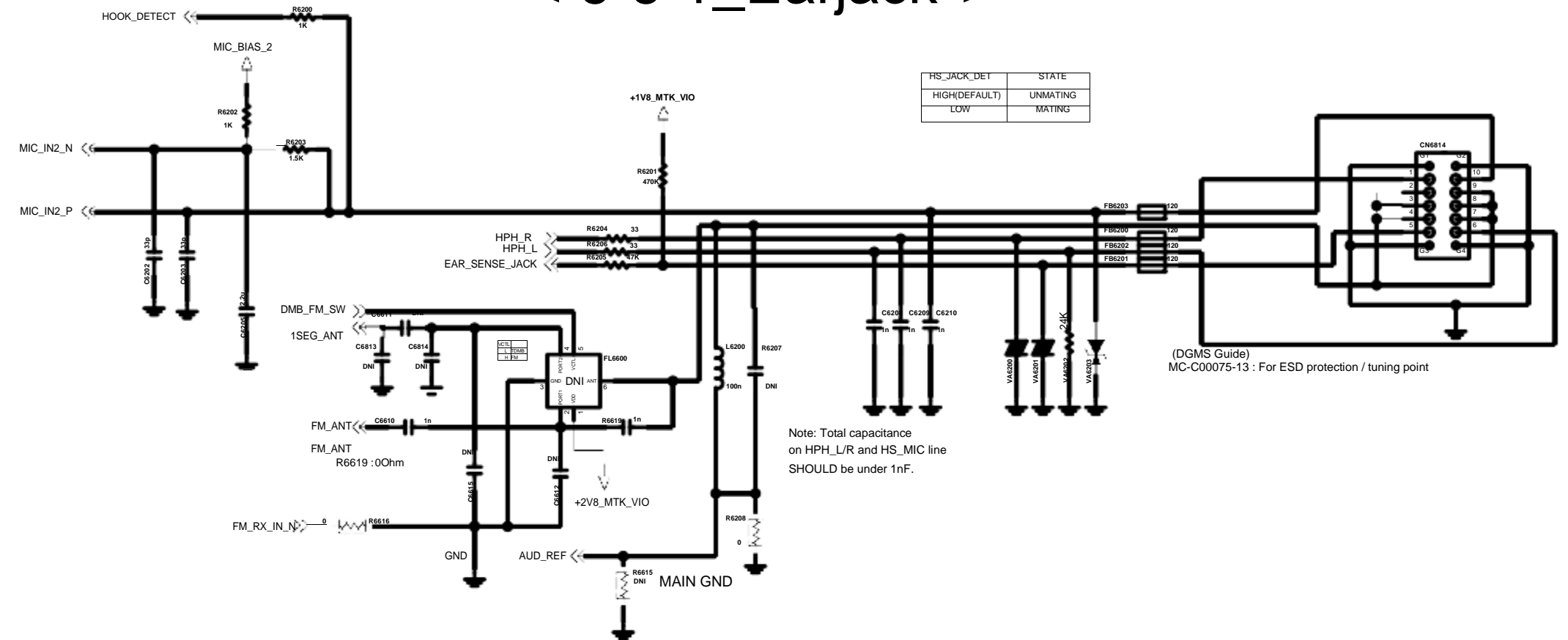

< 6-9-1_MIC > Rev_1.0

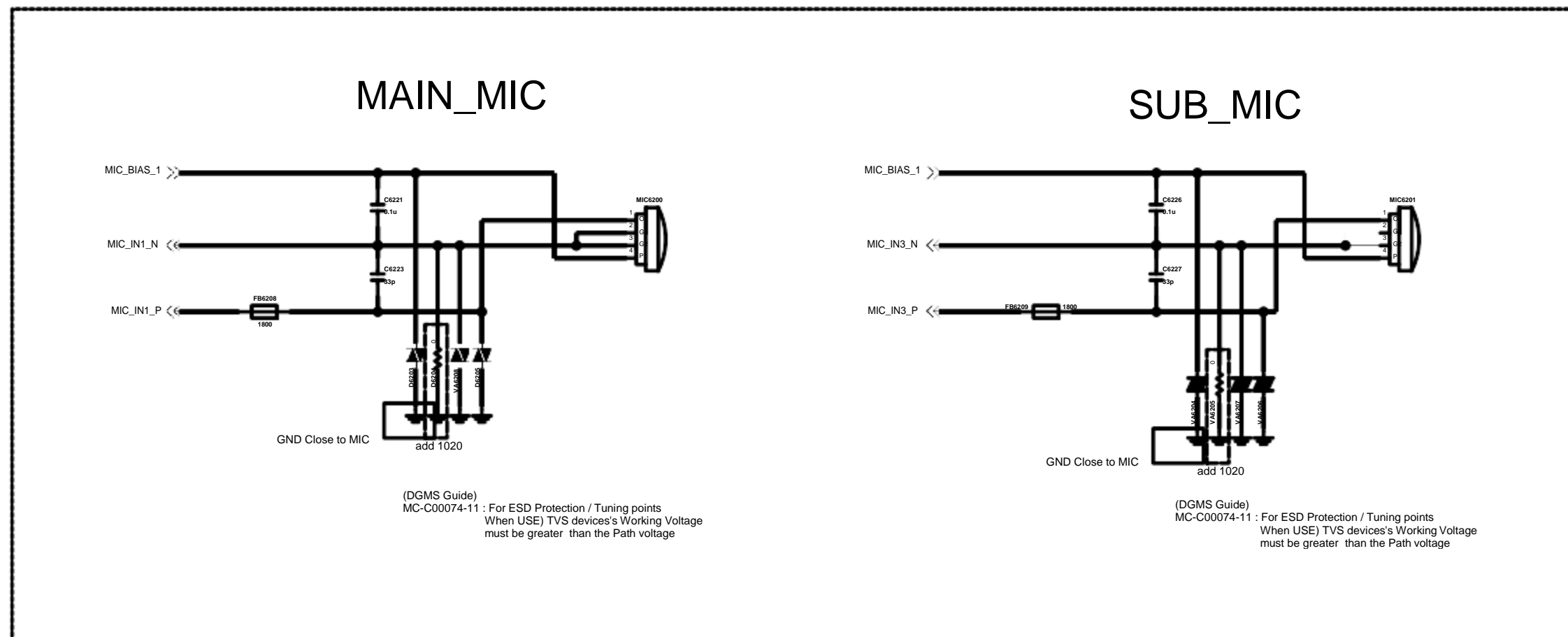

< 6-8-1_Receiver > Rev_1.1

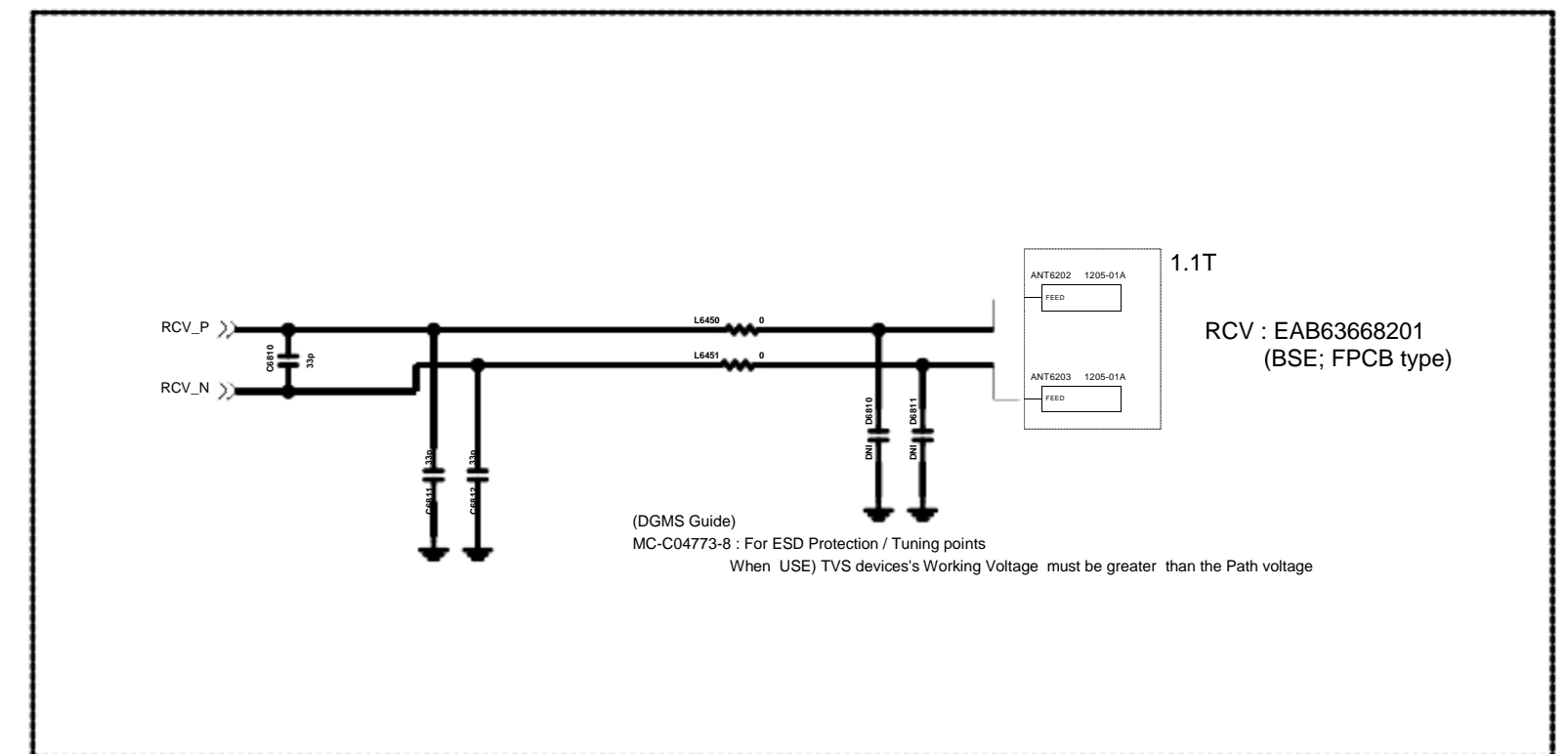

<8-1-2-1_Accel_Compass_BMC150> Rev_1.0

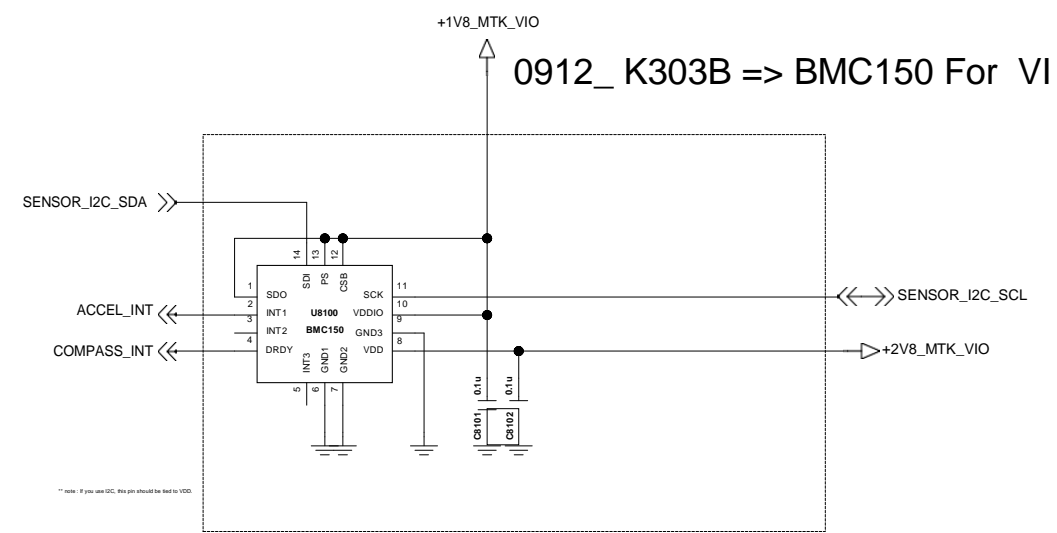

<Proximity_PAS230I1_Partron_2.7T>

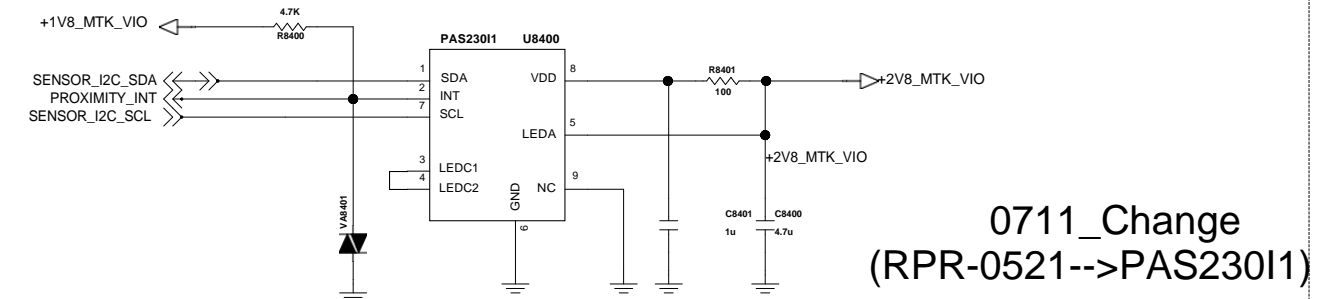

<8-7-1-6_Hall_IC_BU52033NVX>
Rev_1.1 0901_revive

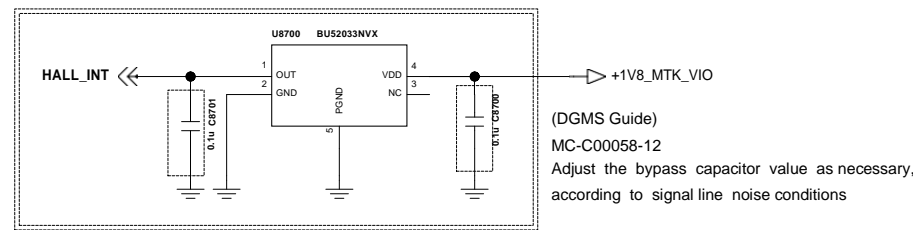

Rev_0.3
< 9-9-1-1_Motor >
9pi Motor

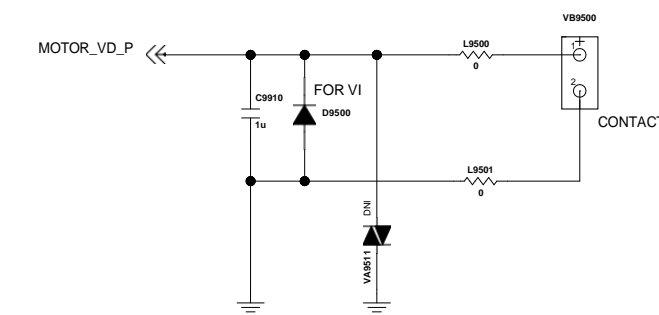

<9-1-2_Battery_CNT_4P>

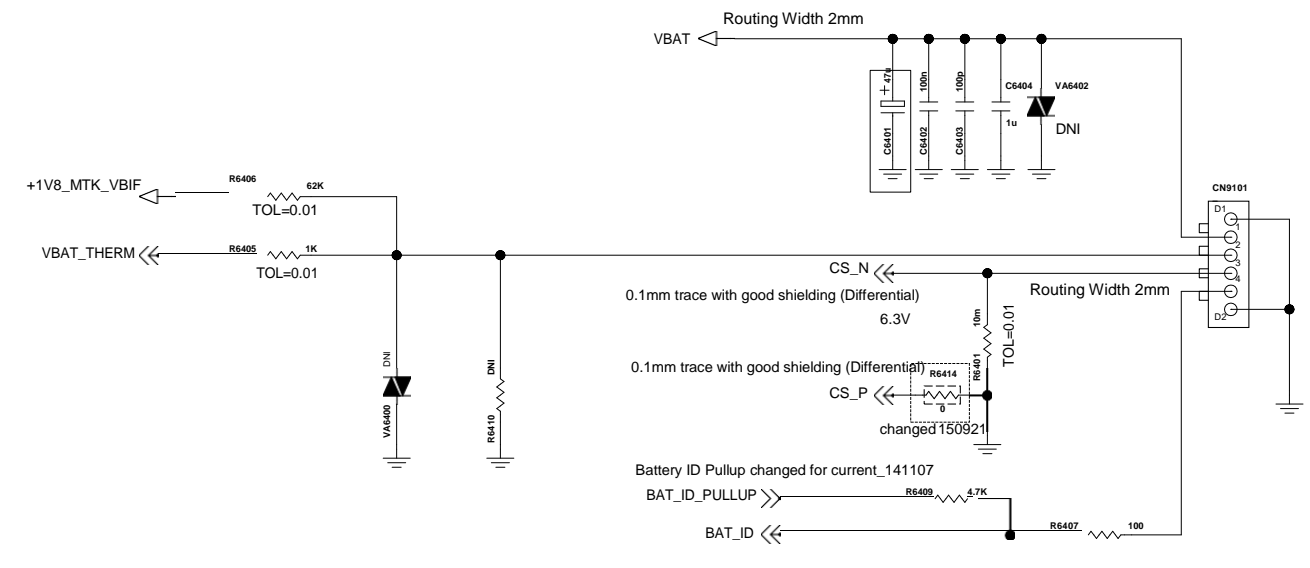

<4-7-1-1_Linear Charger_RT9536>

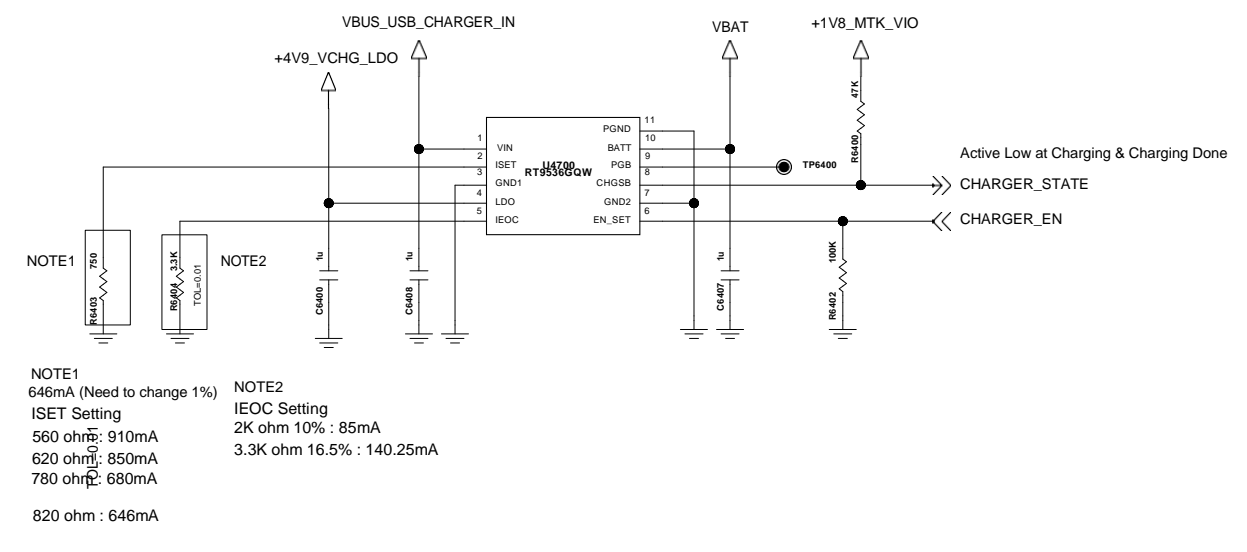

< 9-2-1_IO_USB2.0 >

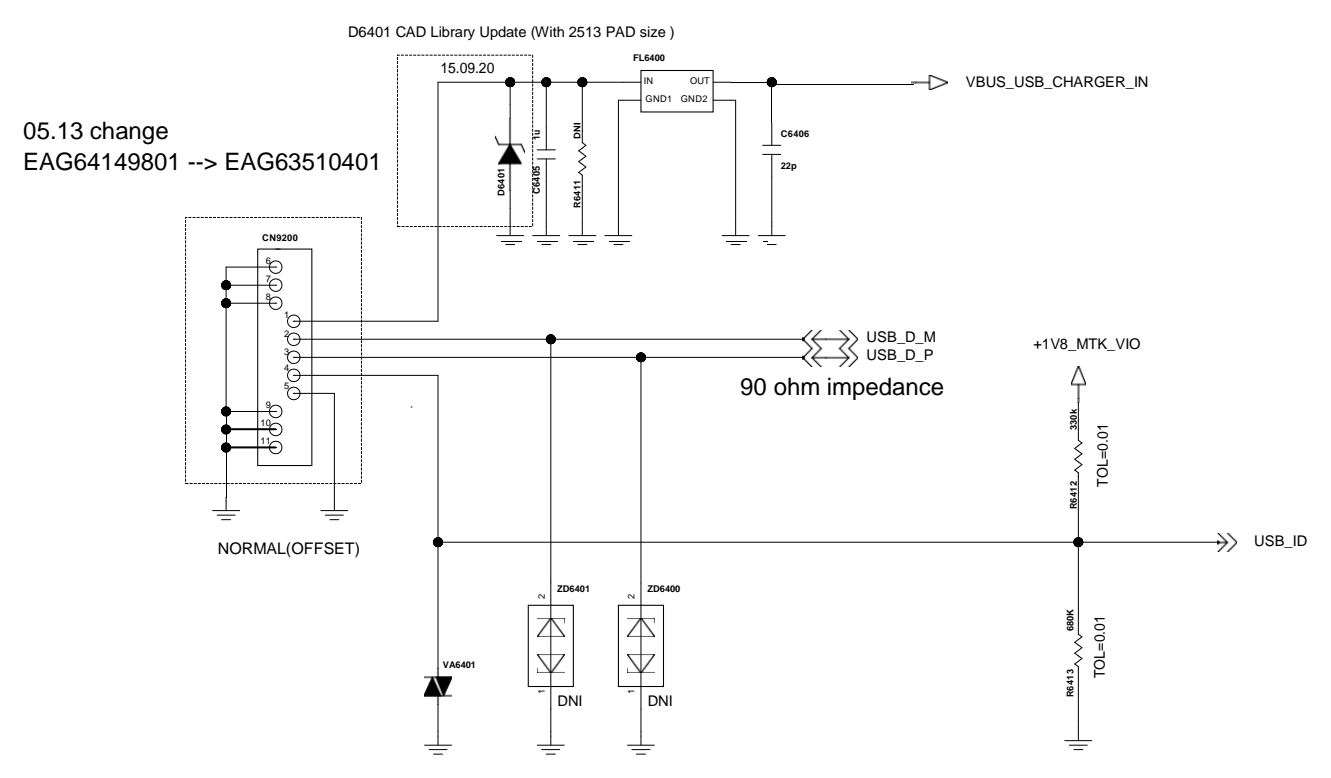

< 9-6_u_SDCARD_Socket > Rev_1.2

Circuit 1. u-SDCARD SIM Combo for QMC /w Low Detection

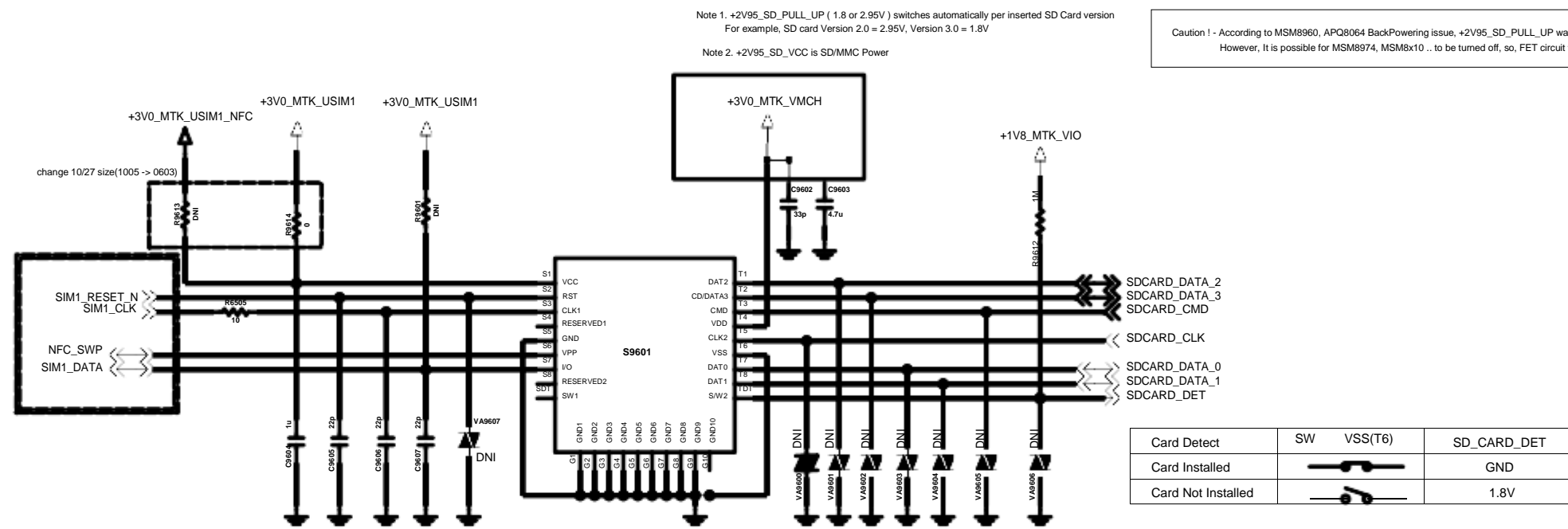

(DGMS Guide)
MC-C04581-13 : Below items should be satisfied

1. SIM_DATA pull-up resistor
2. Use under 33pF (Cap_Varistor) on each signal line
3. When routing, SIM_DATA, SIM_CLK should be seperated
4. CAP,Varistor should Place close to connector

(DGMS Guide)
MC-C04582-14 : Below items should be satisfied

1. SD_DETECT Pull-up or Pull-down
2. Data/CMD line should be needed Pull-up resistor (If chipset has internal Pull-up, comment it on circuit)
3. Use under total 10pF Capacitance on each line ; Data [0:3], CMD - Cap. TVS diode, varistor (on other line, We recommend 10pF capacitance and use under 30pF capacitance)
4. CAP,Varistor should Place close to connector

(DGMS Guide)
MC-C05446-7 : Below items should be satisfied

1. Power of SD card should use independant Power source just like LDO/PMIC which can turn off it.
2. Per chip type which support SD card should manage current capacity. (In case of High speed mode, SD Card Power should get margin of 200mA)
3. Do not connect serial component to SD card power, voltage drop can arise at Power line.

Caution 1 - According to MSM8960, APQ8064 BackPowering issue, +2V95_SD_PULL_UP was Always on during sleep mode. However, it is possible for MSM8974, MSM8x10 .. to be turned off, so, FET circuit to turn off it is not needed any more.

Nano SIM(EAG64650901)

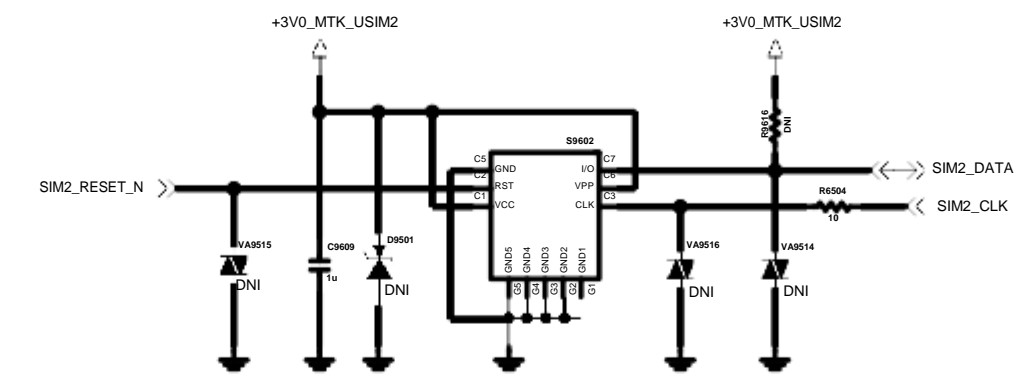

BACK KEY CONNECTOR

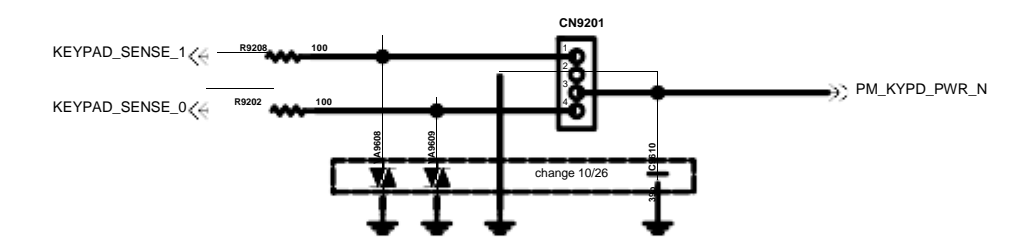

<TOP SHIELD CAN CLIP>

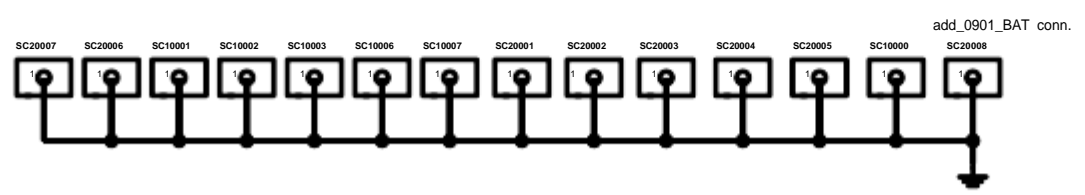

<BOT SHIELD CAN >

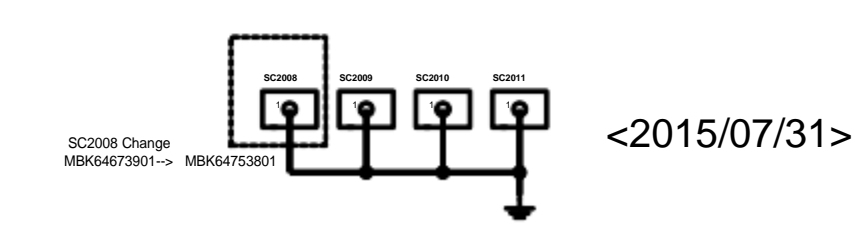

PID 6x6

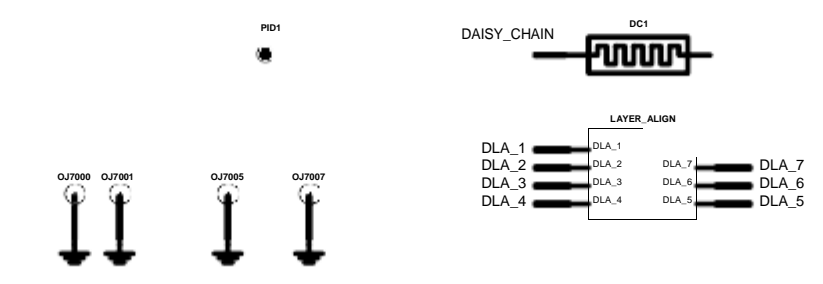

6. BGA PIN MAP

U2100_MT6732_IC,Digital Baseband Processor(Top View)

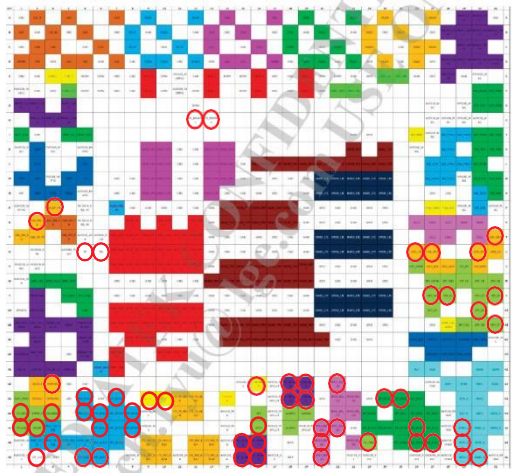

O Not used

U3300_KMQ72000SMB-316,IC,MCP.eMMC4905(Top View)



O Not used

U4100_MT6325_IC,PMIC (Top View)



O Not used

U4200_MT6311_IC,2nd PMIC (Top View)

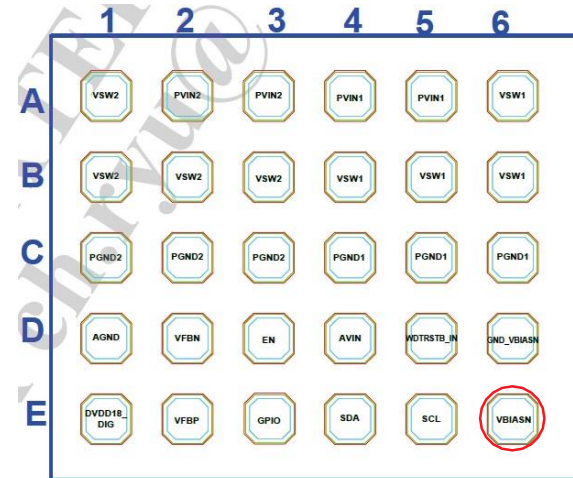

O Not used

LG-K430dsF-MAIN_TOP-1

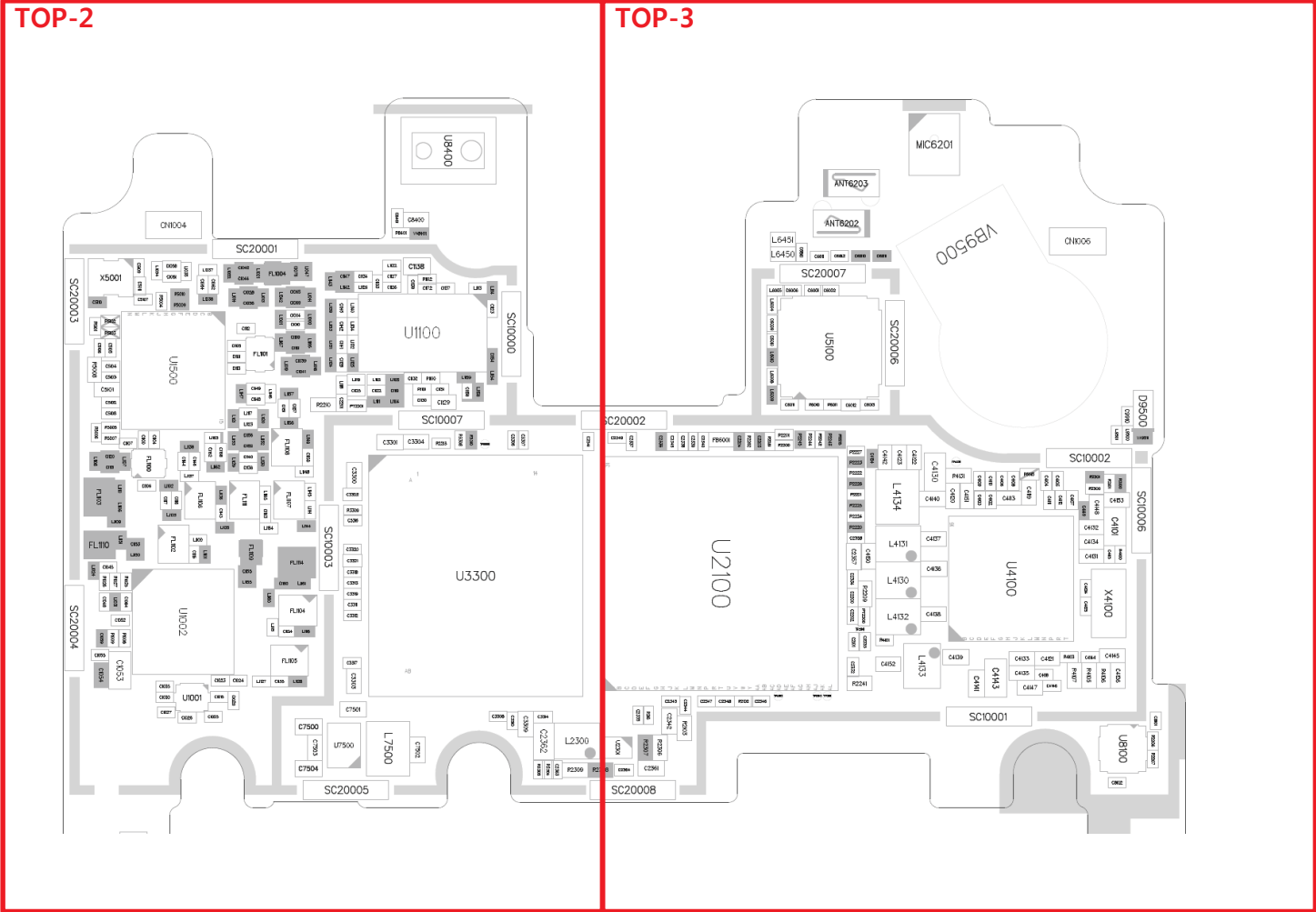

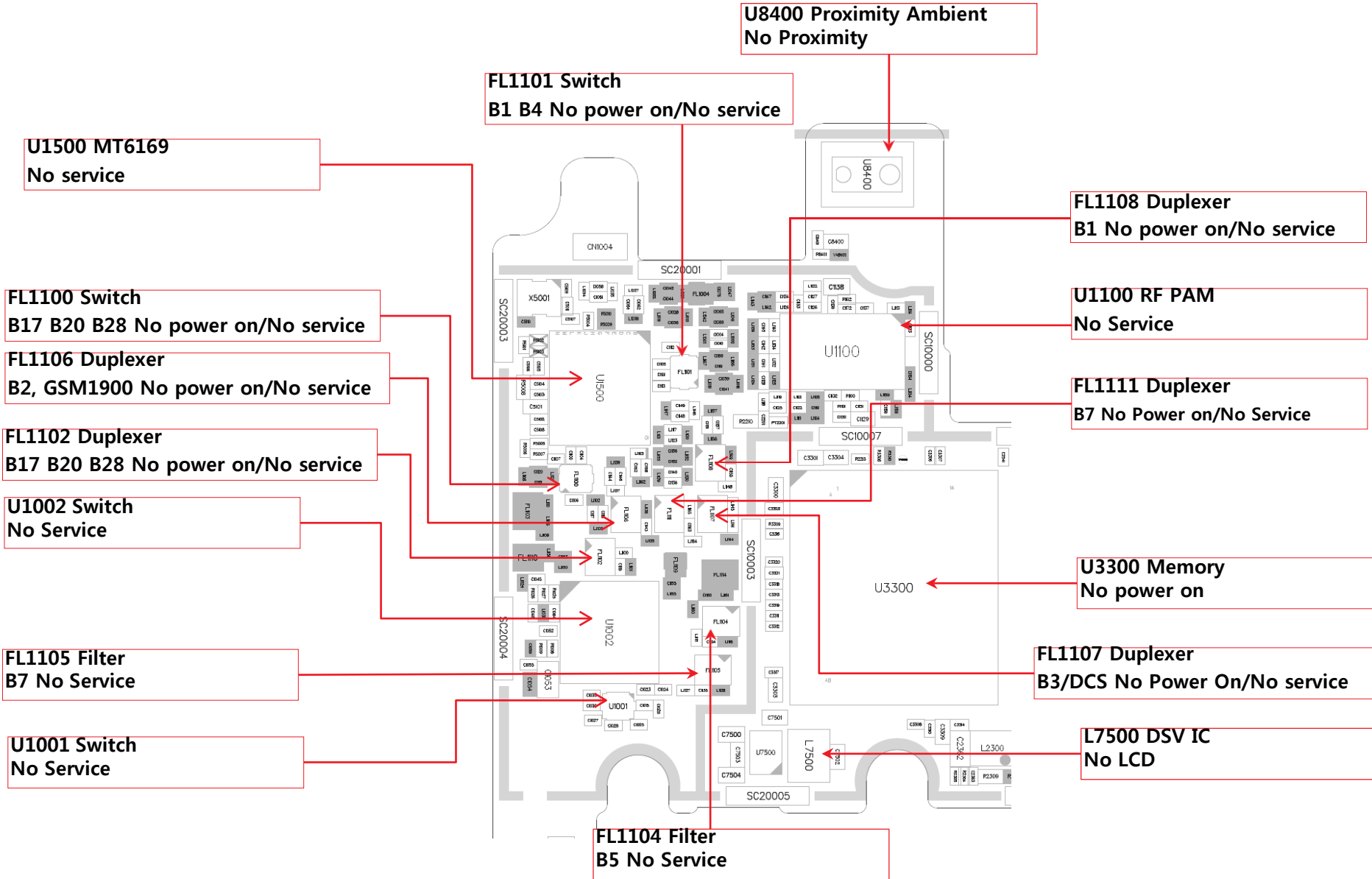

7. PCB LAYOUT

LG-K430dsF-MAIN_TOP-3

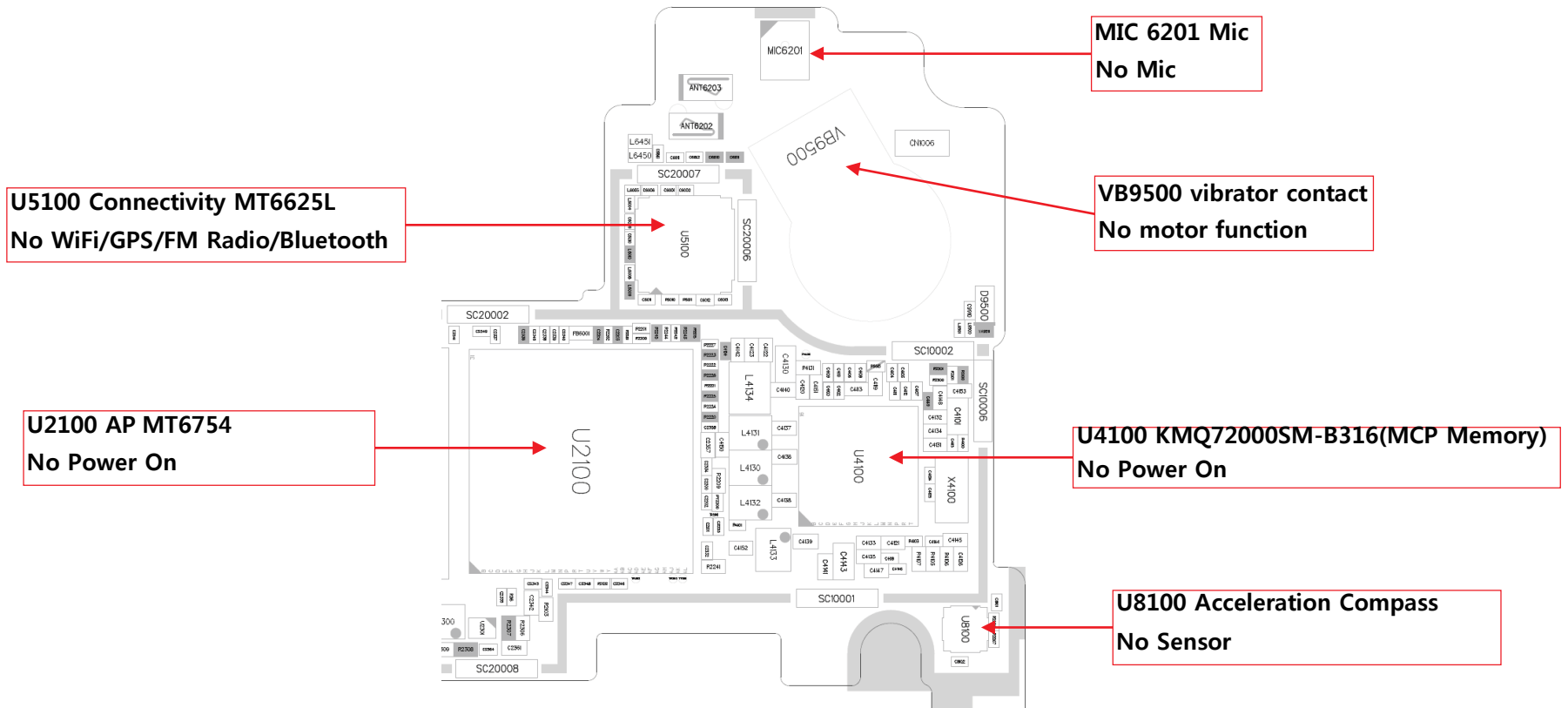

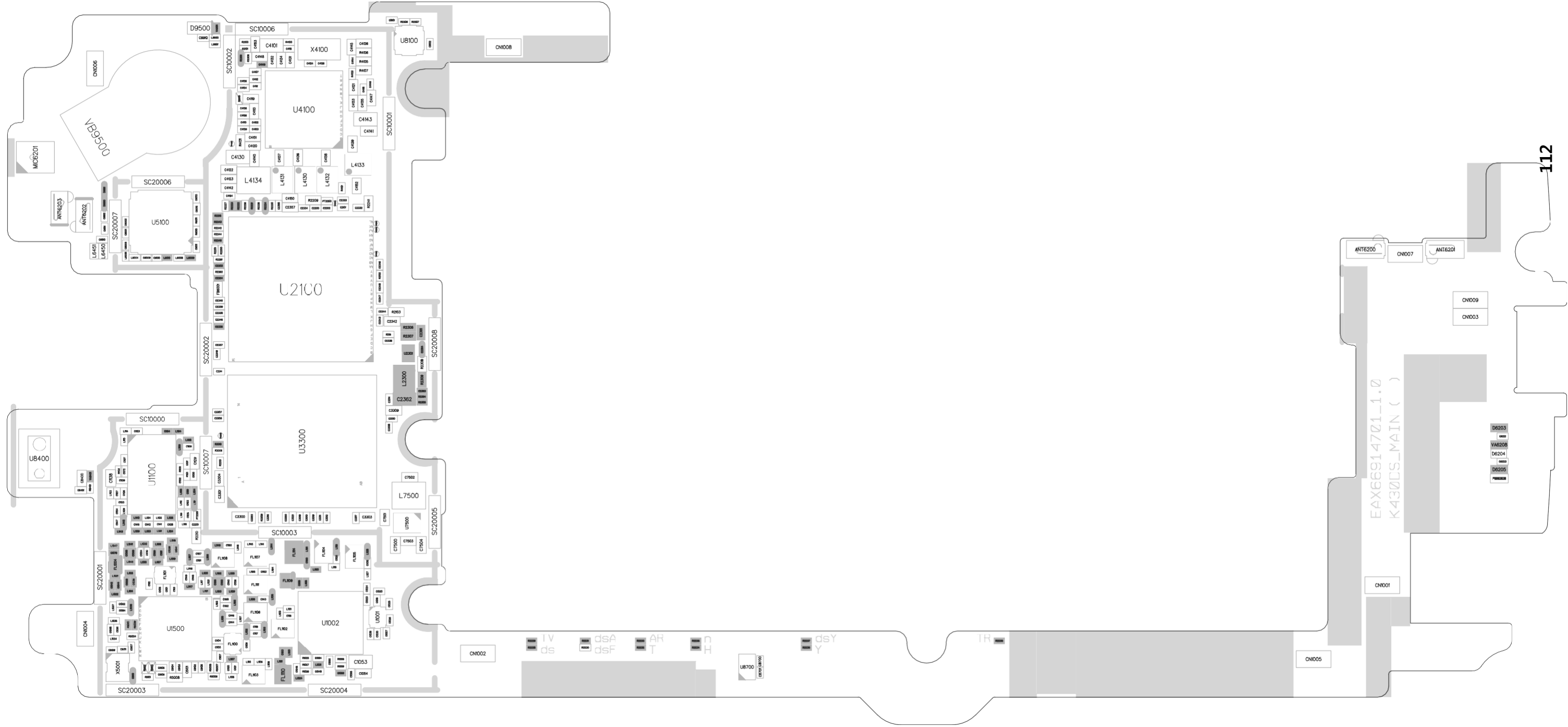

7. PCB LAYOUT

LG-K430dsF-MAIN_BOT-1

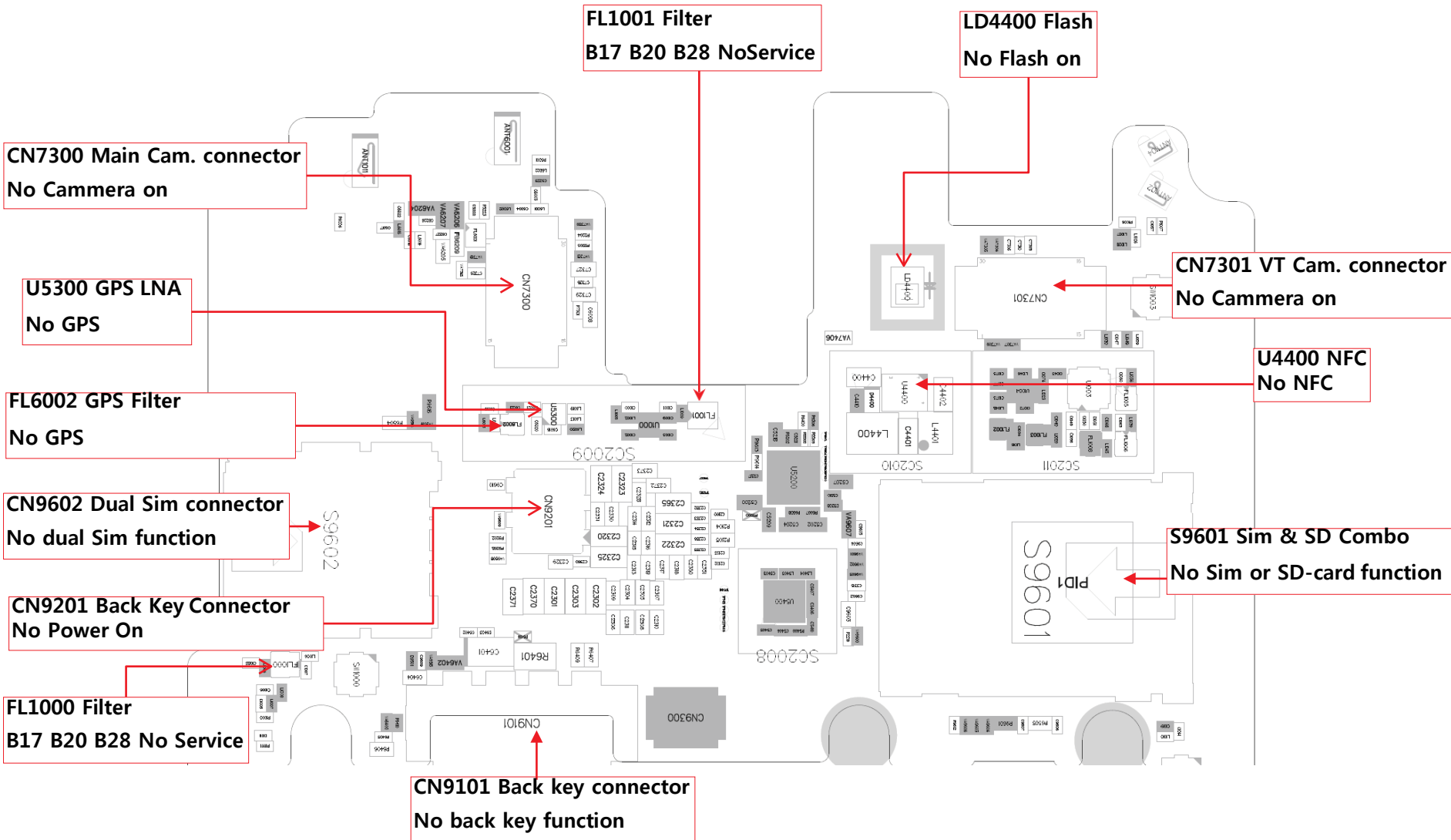

LG-K430dsF-MAIN_BOT-2

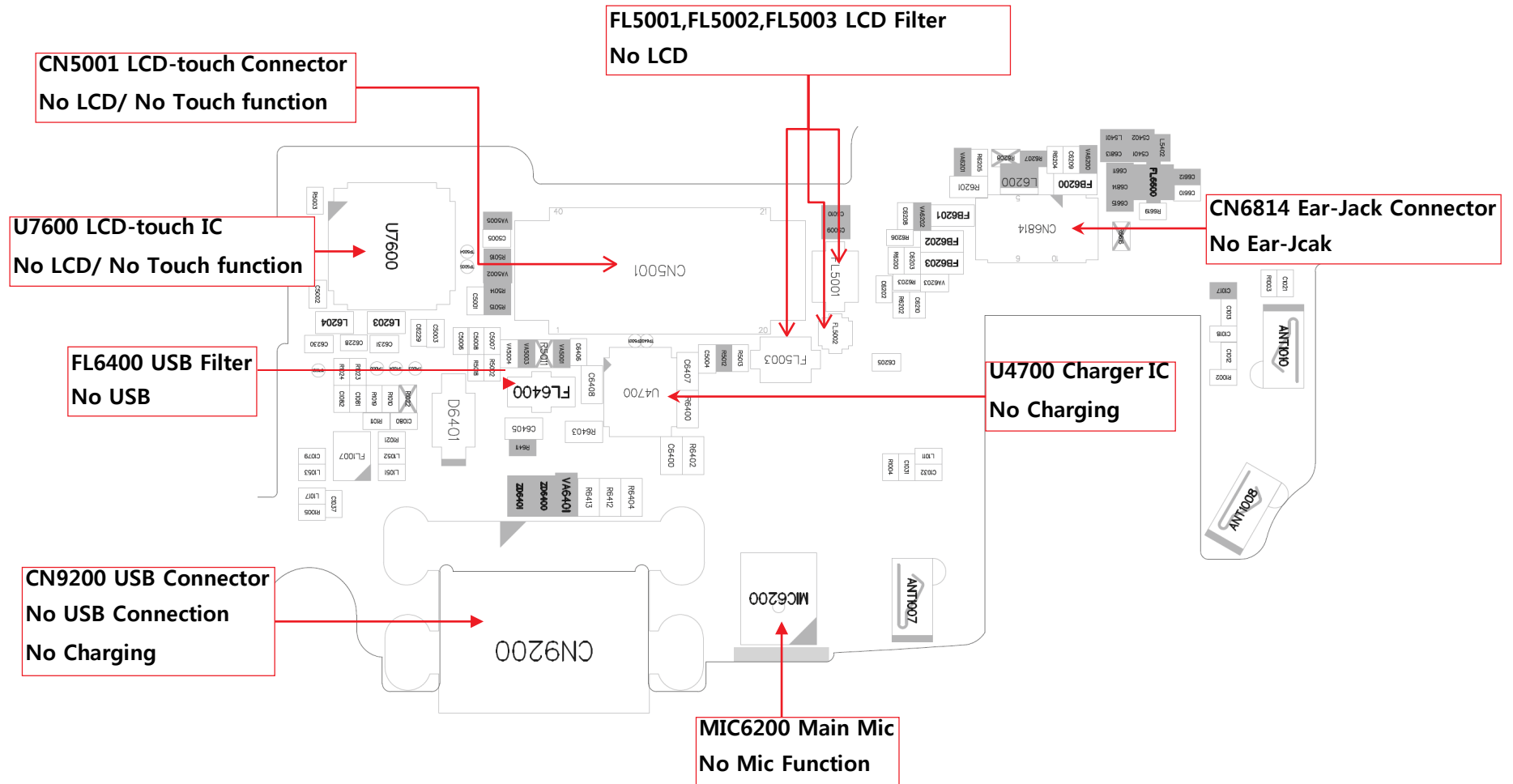

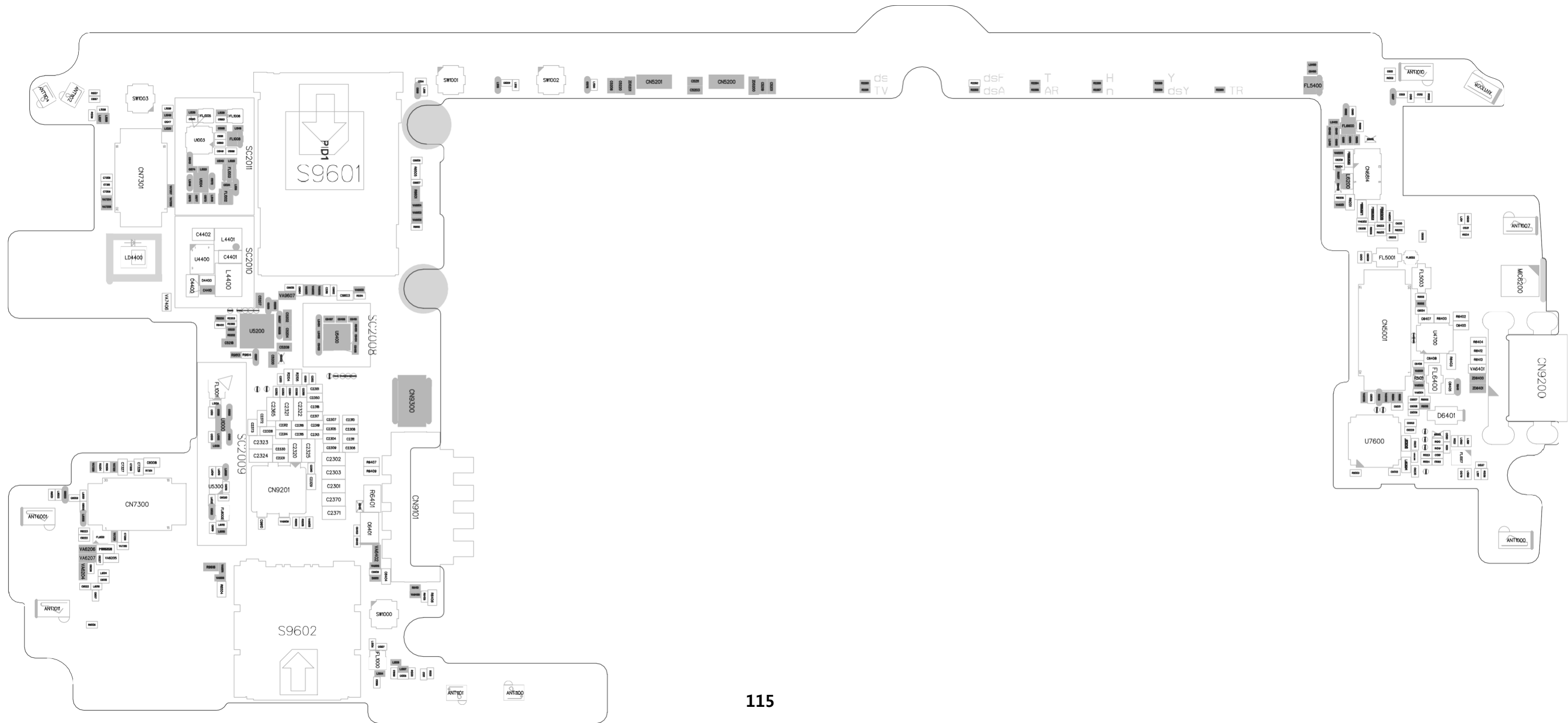

1. Hidden Menu Start

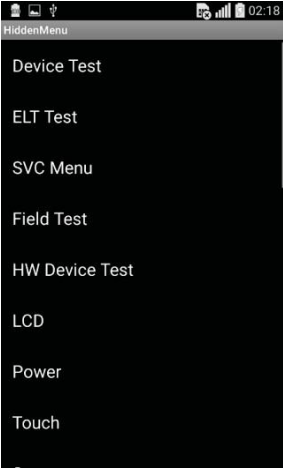

- Start shortcut key:
 ***#546368#*430#**
- Hidden Menu List
 : Start the desired menu, click

2. Device Test

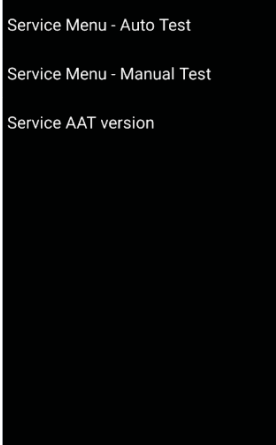

- Service Menu – Auto Test
- Service Menu – Manual Test
- Service AAT version
 → Hidden Menu version Display

2. Device Test

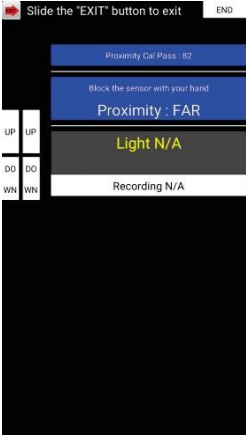



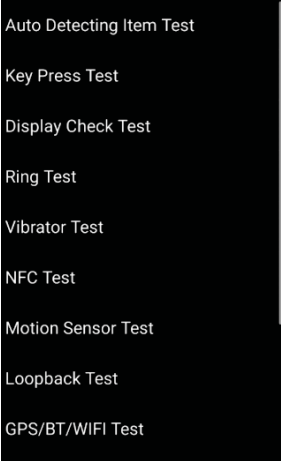

- Service Menu – Auto Test
 → All Test Items are continued one after another.
- Continuous information on the menu, giving you ability test.

3. Device test List



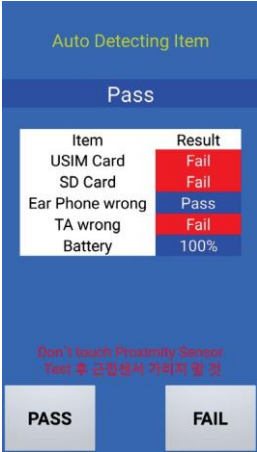

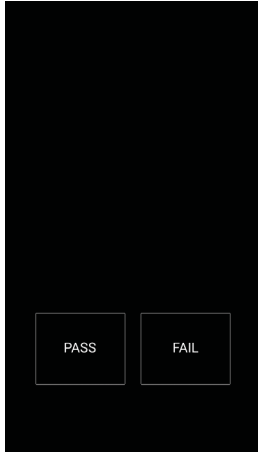
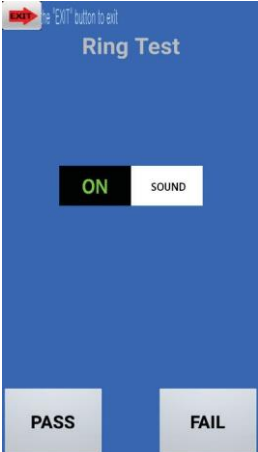
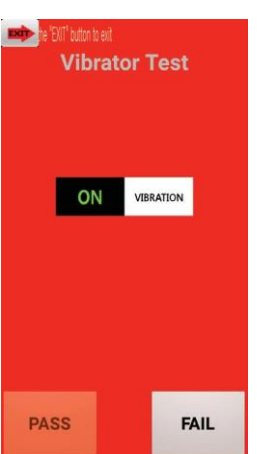
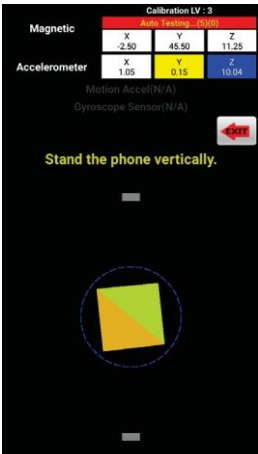
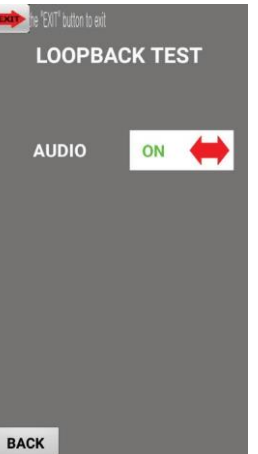

- Service Menu – Manual Test
 → Each test item can be selected and performed by user.

8. HIDDEN MENU

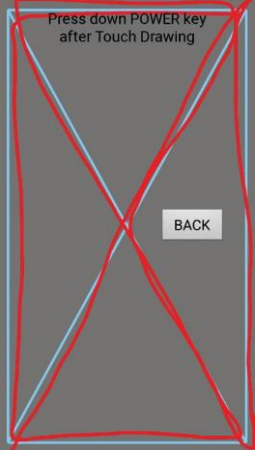
<p>1. Auto Detecting Item Test</p> 	<p>2. Key Press Test</p> 	<p>3. Display Check Test</p> 	<p>4. Ring Test</p> 
<p>5. Vibrator Test</p> 	<p>6. Motion Sensor Test</p> 	<p>7. Loop Back Test</p> 	<p>8. GPS/BT/WIFI Test</p> 

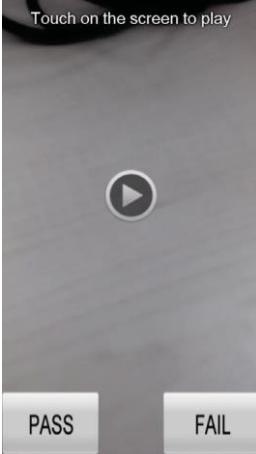
8. HIDDEN MENU

9. Touch Draw -Manual	10. Camera(Main) Test	11. Camcorder Test	12. Camera(VT) Test
 <p>Press down POWER key after Touch Drawing</p> <p>BACK</p>	 <p>Verify the picture</p> <p>PASS Retry FAIL</p>	 <p>Touch on the screen to play</p> <p>PASS FAIL</p>	 <p>VT Camera Test</p> <p>1280x720</p> <p>PASS FAIL</p>

1. Summary

Tool Version	DLL name	USB Driver	
LG flash tool 2.0.1.5	LGK430ds_20160128_LGFLAS Hv215.dll	LGUnitedMobileDriver_S50MAN311AP22_ML_WHQL_Ver_3.11.3	
Please Check the Version to "B2B"			
H/W	Name	Part No.	SW
D/L Cable	Micro 5P (56-open-910K) USB DLC		TOT/KDZ



2. . USB COM port Setting

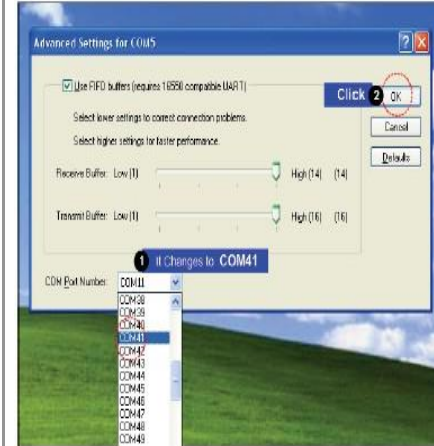

3. USB D/L Cable setting



4. Flash tool D/L setting

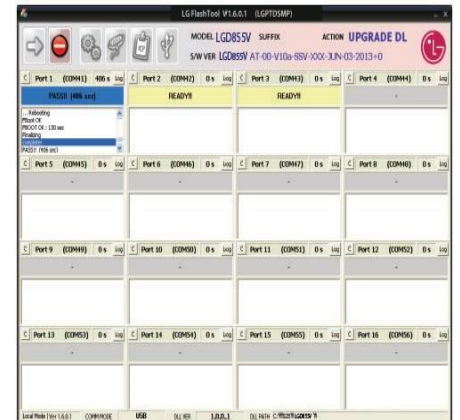
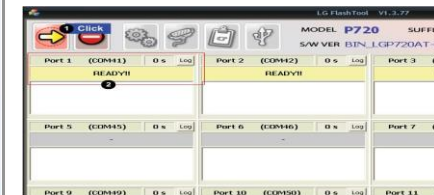
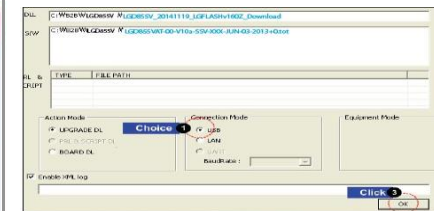

※ If you want more information, please refer B2B's Notification "Download User Guide".

1. Summary

CAL INFORMATION		
S/W VERSION		
Please Check the Version to "B2B"		
H/W		
	Name	Part No.
PIF	PIF200	BJAY0024021
USB Cable	USB Cable	RAD32247898
Power Cable	DC Power Cable	RAD32247878
I/O Cable		
RF Cable Main		
Power Supply PIF		
Power Supply Phone	Power supply 5.0V	
PF Test Equipment		
Notice	1. Use the Battery (Refer to Attached ppt)	
	2) If do not use the battery, TX fails.	
CMW 500 RF Cable connection	1) Uart Port1 : Use the "LGE Mobile USB Serial Port"	

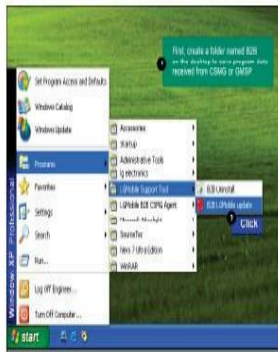

2. . USB COM port Setting

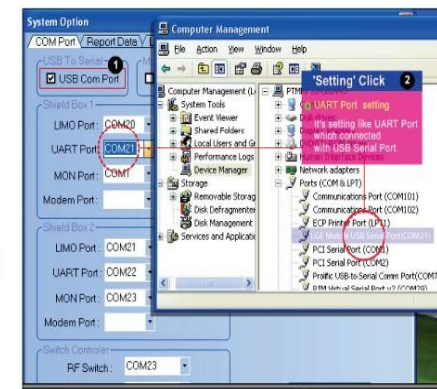
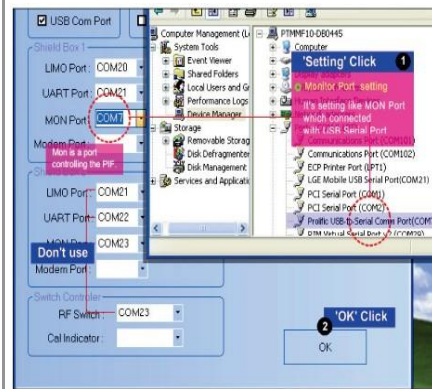

3. Calibration Cable setting

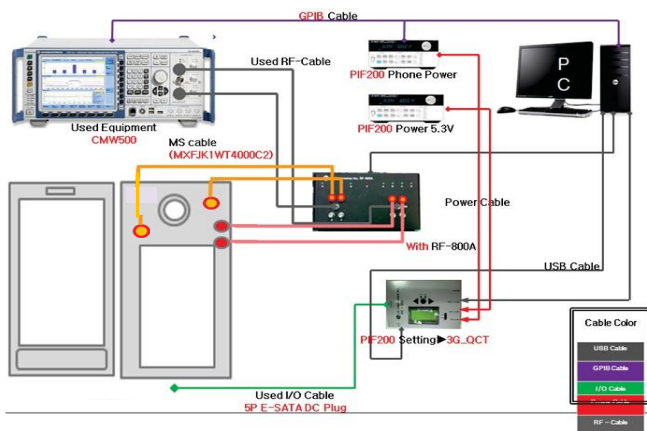

4. Calibration Tool

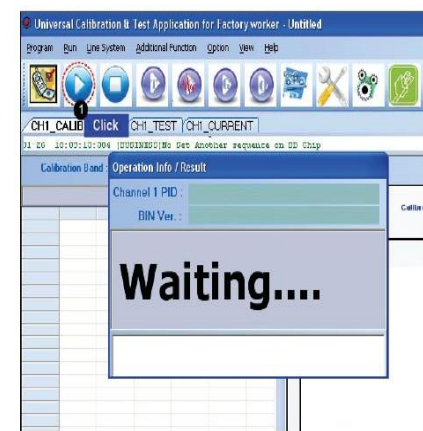
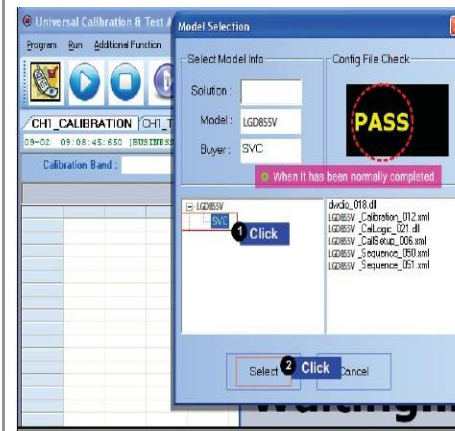

Removal of Battery Cover

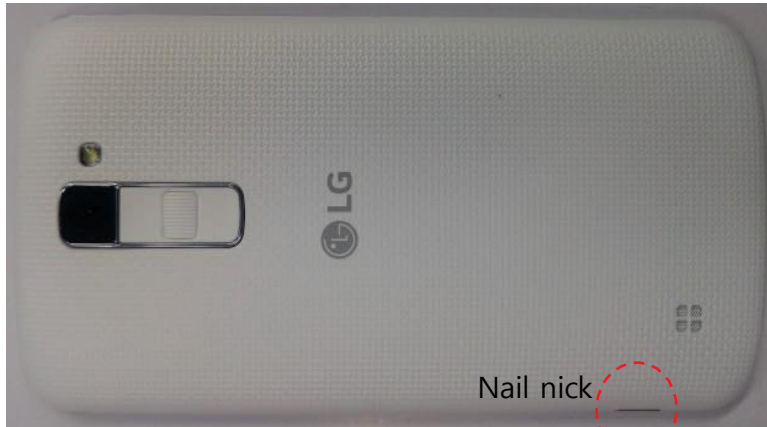

Removal of battery cover using nail nick shown in red circle



Removal of Battery



Removal of battery using nail nick shown in red circle

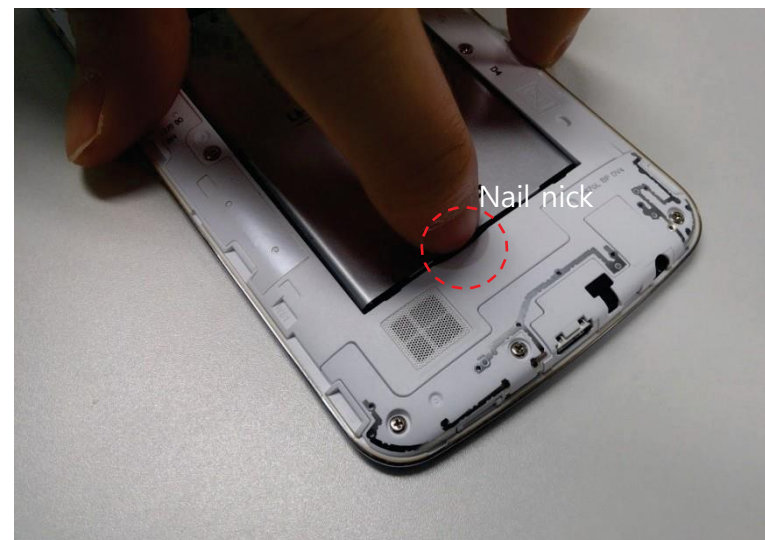

Removal of Rear Cover

1) Unfastening of 11 screws shown in red circle

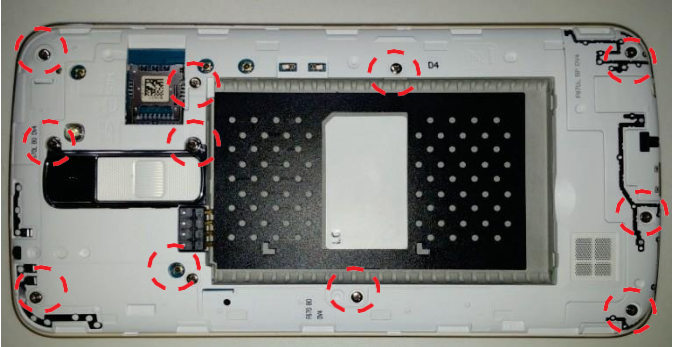

2) Disassembly of hooks on left, right and top sides (Left figure) with the directions shown in right figure.

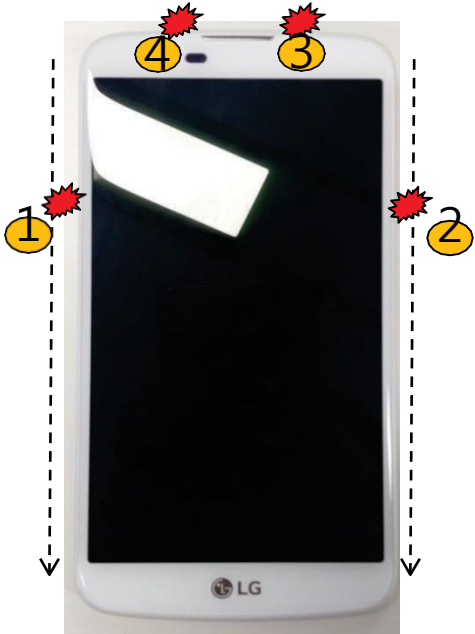

3) Moving of rear cover in the direction shown in figure without disassembly of bottom side of the rear cover



PCB Remove

Disconnection of connectors
shown in red circle

-Total 4 points

Removal step of PCB

1. Bottom side hook

2. Top side hook

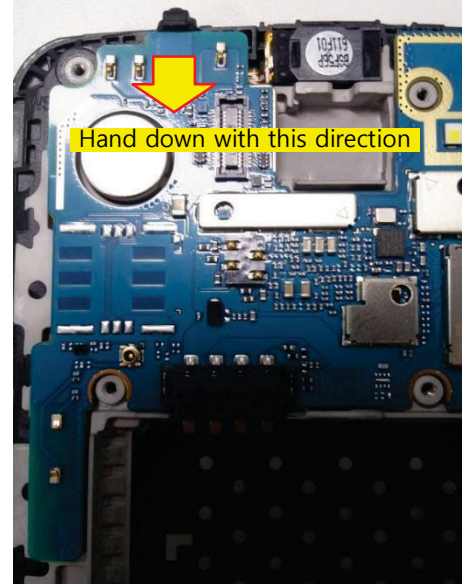
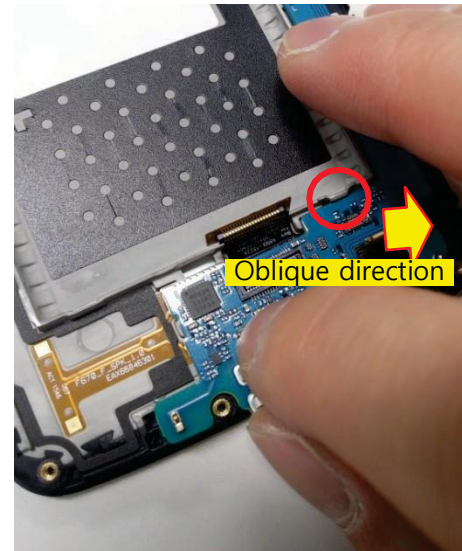
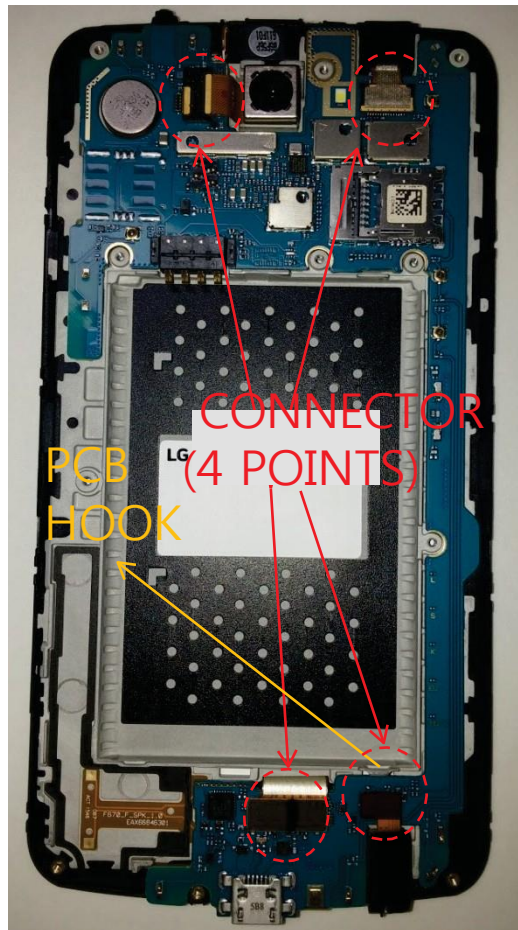

11. DISASSEMBLE GUIDE

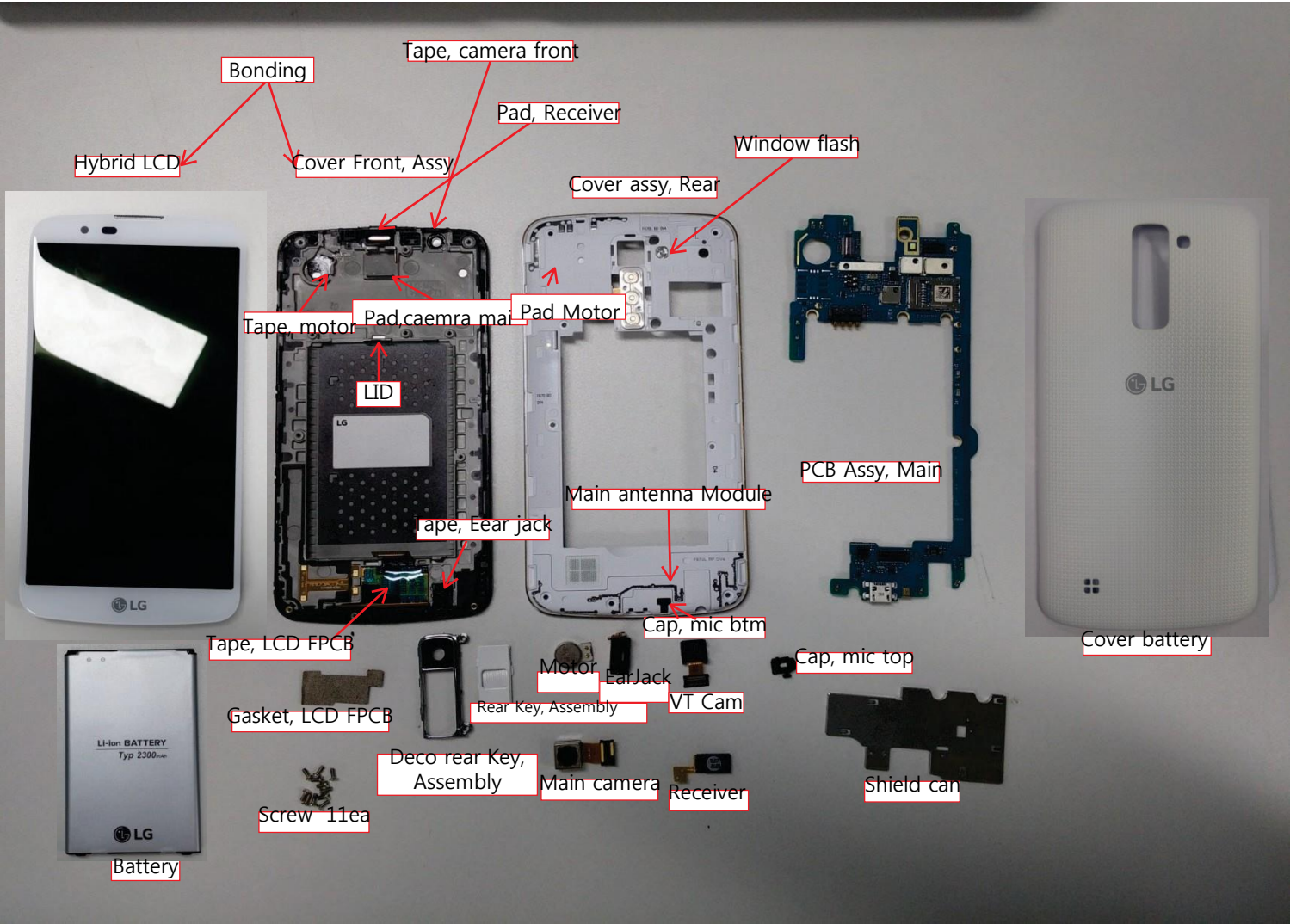

12. EXPLODED VIEW

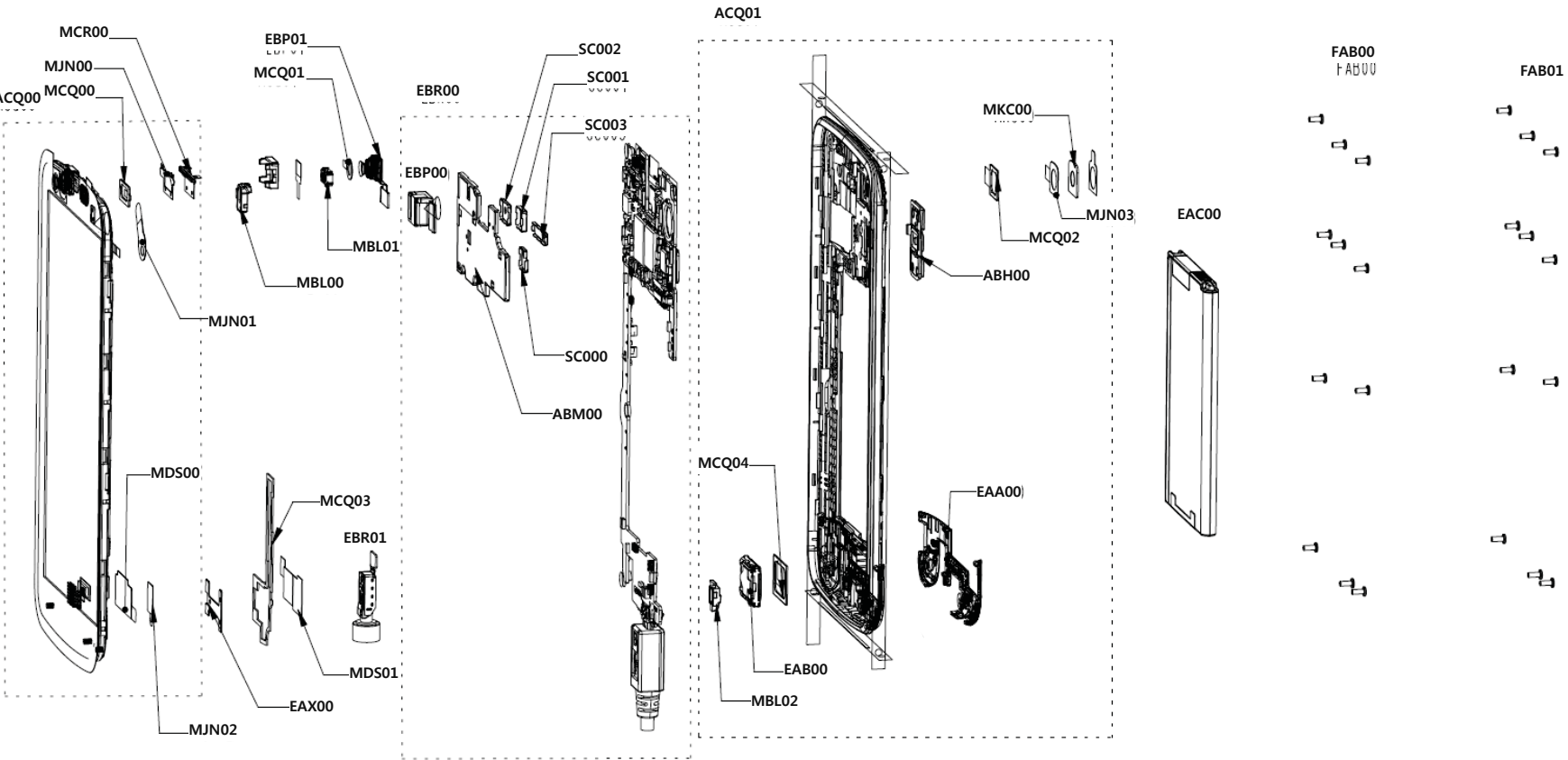

Location	Description	Location	Description	Location	Description	Location	Description
EBR00	PCB Assembly,Main	MDS01	Gasket	EBR01	PCB Assembly,Flexible	EAA00	PIFA Antenna,Multiple
SC000	Can,Shield	MCQ00	Damper	MBL00	Cap	FAB00	Screw,Machine
SC001	Can,Shield	MCR00	Decor	ACQ01	Cover Assembly,Rear	FAB01	Screw,Tapping
SC002	Can,Shield	MDS00	Gasket	MCQ04	Damper,Speaker	EAC00	Rechargeable Battery,Lithium Ion
SC003	Can,Shield	MJN01	Tape	MBL02	Cap		
ABM00	Can Assembly,Shield	MJN02	Tape	ABH00	Button Assembly		
EBP00	Camera Module	MJN00	Tape	MKC00	Window,Camera		
ACQ00	Cover Assembly	MCQ01	Damper,Camera	MCQ02	Damper,Camera		
MCQ03	Damper,Speaker	MBL01	Cap	MJN03	Tape,Window		
EAX00	PCB,Sub	EBP01	Camera Module	EAB00	Speaker,Dual Mode		

13. REPLACEMENT PART LIST

P/N	Location no	Description
EBR82267401	EBR00	PCB Assembly,Main
EXXY0018701	X4100	Crystal
MBV62321701	SC10000,SC10001,SC10002,SC10003,SC10006,SC10007,SC20001,SC20002,SC20003,SC20004,SC20005,SC20006,SC20007,SC20008	Clip
SFBH0008102	FB6208	Filter,Bead
EAB62950801	MIC6201	Microphone,Condenser
EAG64389801	ANT6202,ANT6203	C-Clip
EAG64451301	CN1003,CN1009	Connector,Terminal
EAG64451501	CN1001,CN1002,CN1004,CN1005,CN1006,CN1007,CN1008	Connector,Terminal
EAG64851501	ANT6200,ANT6201	C-Clip
EAM62792601	FL1100,FL1101	Filter,Separator,Switch
EAM63950301	FL1108	Filter,Duplexer
EAM63290701	FL1103	Filter,Duplexer
EAM63431001	FL1102	Filter,Duplexer
EAM63950001	U1001	Filter,Separator,Switch
EAM63950601	FL1111	Filter,Duplexer
EAM63950701	FL1105	Filter,Duplexer
EAM63990101	FL1107	Filter,Duplexer
EAM63990401	FL1106	Filter,Duplexer
EAM63990501	FL1104	Filter,Duplexer
EAN62637201	U8100	IC,Acceleration Sensor
EAN62867201	U8700	IC,Hall Effect Switch
EAN63406501	U1500	IC,RF Transceiver,4G
EAN63486501	U5100	IC,WiFi
EAN63748001	U4100	IC,PMIC
EAN64089201	U8400	IC,Proximity
EAN64089501	U7500	IC,DC,DC Converter
EAN64106301	U2100	IC,Digital Baseband Processor,4G
EAN64107501	U1100	IC,Power Amplifier
EAT63233201	U1002	Module,Tx Module
EAW62983801	X5001	Oscillator,VCTCXO
EBG62665701	PT2200,PT2201	Thermistor,NTC
EDSY0010501	D9500	Diode,Switching
EAN64227201	U3300	IC,MCP,eMMC
EAM63450301	FL1001	Filter,Saw
EAM63491001	FL1000	Filter,Saw
EAB62950801	MIC6201	Microphone,Condenser
EAG63772101	SW1000,SW1001,SW1002,SW1003	Connector,RF
EAG64051601	CN9101	Connector,Terminal Block
EAG64149801	CN9200	Connector,I/O

13. REPLACEMENT PART LIST

EAG64370001	CN9201	Connector,Terminal Block
EAG64389801	ANT6202,ANT6203	C-Clip
EAG64650901	S9602	Socket,DIMM/SIMM
EAH61992801	D4400	Diode,Schottky
EAG64672301	ANT1100,ANT1101,ANT1102,ANT1104	C-Clip
EAG64729801	CN6814	Connector,BtoB
EAG64850201	S9601	Socket,DIMM/SIMM
EAH62033201	VA6203	Diode,TVS
EAH63092501	D6401	Diode,TVS
EAM63130101	FL6002	Filter,Saw
EAM63510201	U1003	Filter,Separator,Switch
EAM63670001	FL6001	Filter,Saw
EAM63930901	FL1006	Filter,Saw
EAM63992001	FL1007	Filter,Separator,Switch
EAN62677301	U4700	IC,Charger
EAN62736101	U5300	IC,RF Amplifier
EAN62766201	U4400	IC,DC,DC Converter
EAN64011501	U7600	IC,Capacitive Touch Sensor
EAV62991901	LD4400	LED,Flash
ENBY0036001	CN5001	Connector,BtoB
ENBY0040701	CN7300,CN7301	Connector,BtoB
MBK64753801	SC000	Can,Shield
MBK64633901	SC001	Can,Shield
MBK64674001	SC002	Can,Shield
MBK64693101	SC003	Can,Shield
SEVY0003601	VA7406	Varistor
SEVY0008102	VA7318	Varistor
SEVY0008901	C6230,C6231,VA5004	Varistor
SFBH0007101	FB6200,FB6201,FB6202,FB6203	Filter,Bead
SFBH0008102	FB6208	Filter,Bead
SFEY0015301	FL6400	Filter,EMI/Power
EAM63390601	FL1005	Filter,Saw
EAM62570201	FL5002	Filter,EMI/Power
EAM62630501	FL5001,FL5003	Filter,EMI/Power
SEVY0007902	VA9608,VA9609	Varistor
SEVY0005402	VA6401	Varistor
ABM75276402	ABM00	Can Assembly,Shield
EBP62762101	EBP00	Camera Module
ACQ88868302	ACQ00	Cover Assembly
MCO68825501	MCO03	Damper,Speaker

13. REPLACEMENT PART LIST

EAX66846301	EAX00	PCB,Sub
MDS65591201	MDS01	Gasket
MCQ68825301	MCQ00	Damper
MCR66452001	MCR00	Decor
MDS65591001	MDS00	Gasket
MJN69967701	MJN01	Tape
MJN69948501	MJN02	Tape
MJN69928601	MJN00	Tape
MCQ68825401	MCQ01	Damper,Camera
MBL66859701	MBL01	Cap
EAB63668201	EAB010400	Receiver
EAU63423301	EAU010000	Motor,DC
EBP62722001	EBP01	Camera Module
EBR81629201	EBR01	PCB Assembly,Flexible
MBL66859601	MBL00	Cap
MJN69932101	MJN061100	Tape,Protect
ACQ88635702	ACQ01	Cover Assembly,Rear
MCQ68806101	MCQ04	Damper,Speaker
MBL66841601	MBL02	Cap
EAX66728101	EBR070500	PCB,Flexible
ABH75839802	ABH00	Button Assembly
MKC65940601	MKC00	Window,Camera
MJN69949101	MJN061100	Tape,Protect
MCQ68805601	MCQ02	Damper,Camera
MJN69988901	MJN03	Tape,Window
EAB64188201	EAB00	Speaker,Dual Mode
EAA64286401	EAA00	PIFA Antenna,Multiple
GMEY0014301	FAB00	Screw,Machine
FAB32218901	FAB01	Screw,Tapping
MEZ66387422	MEZ002100	Label,Approval
EAB64228801	EAB010200	Earphone,Stereo
EAD62377902	EAD010000	Cable,Assembly
EAY62751801	EAY060000	Adapters
MCK69135204	MCK004100	Cover,Battery
MJN69928806	MJN107400	Tape,USP Film
MBM65438701	MBM062600	Card,Quick Reference
EAC63158307	EAC00	Rechargeable Battery,Lithium Ion